

# FOLD OUT

# SINGLE SOUNDS

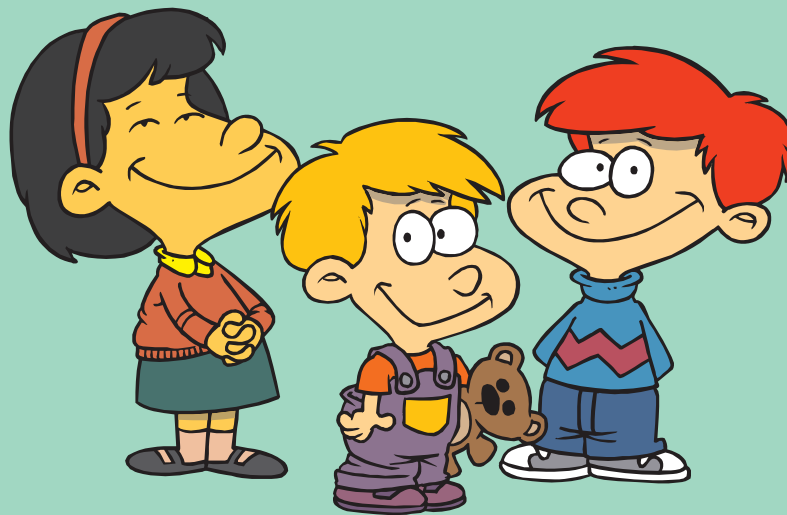

Cutting, Pasting, Writing

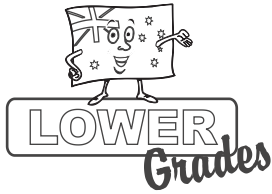

EDUCATIONAL  
WORKSHEETS

# FOLD OUT SINGLE SOUNDS

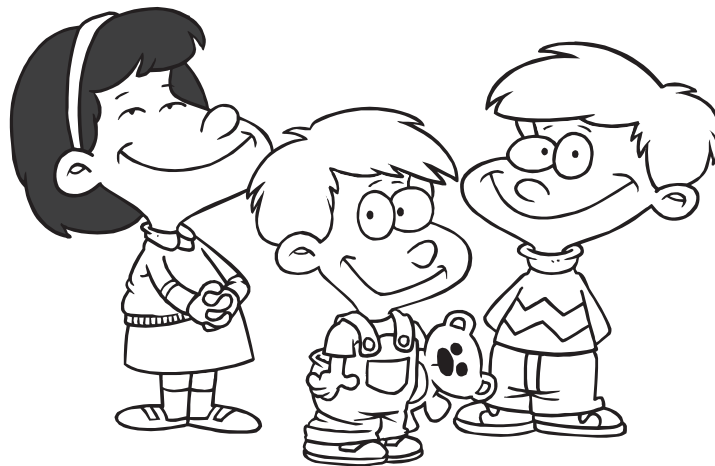

**Cutting, Pasting, Writing**

**BURRA BOOKS**  
  
[www.burrabooks.com.au](http://www.burrabooks.com.au)

## **Fold Out Single Sounds**

written by Louise and Greg Porich

© Burrabooks Pty Ltd.

First Published 2005

ABN 22 070 006 085

P. O. Box 611,

Moruya NSW 2537

Ph: 0244 742 355

Fax: 0244 742 399

[www.burrabooks.com.au](http://www.burrabooks.com.au)

All rights reserved.

### **COPYING FOR EDUCATIONAL PURPOSES**

The purchaser of this book is granted permission by the publisher to make copies of the pages within the book, beyond their rights under the Australian Copyright Act 1968 (the Act), provided that the number of copies made does not exceed the number reasonably required for use in one classroom only; that copies are only made by photocopying and are not copied, stored or transmitted by any electronic or digital means; copies are not sold or lent. Copying of this book outside this licence may fall within the educational statutory licence under the Act.

### **COPYING FOR OTHER PURPOSES**

Unless copying is specifically permitted by the educational statutory licence, the licence granted to the purchaser of this book or the fair dealing clause in the Act (for the purposes of study, research, criticism or review), no part of this book may be reproduced, stored in a retrieval system, transmitted in any form or by any means without prior written permission from the publisher.

Some images used with permission of Ron Leishman.

As with all Burrabooks publications every attempt is made to acknowledge copyright. Any infringements are purely coincidental and the publisher offers apologies where applicable.

ISBN 1 92098 214 0

# **BUR-5025**

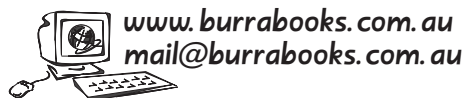

# INTRODUCTION

'Fold Out Single Sounds' has been designed to develop the recognition of single sounds in the beginning, middle and final positions within words.

The photocopyable sheets in this book can be used in a number of different ways e.g.

- The students colour the pictures and write the missing sound on the picture page. They then trace the sounds on the sound page and cut out the squares. These squares are then pasted over the matching picture on the picture page. The students can then fold along the dotted line and lift up the sound door to see the picture underneath. The completed exercise results in an A4 sheet with six flaps (with sounds on them) that can be lifted to reveal the matching picture and word underneath.

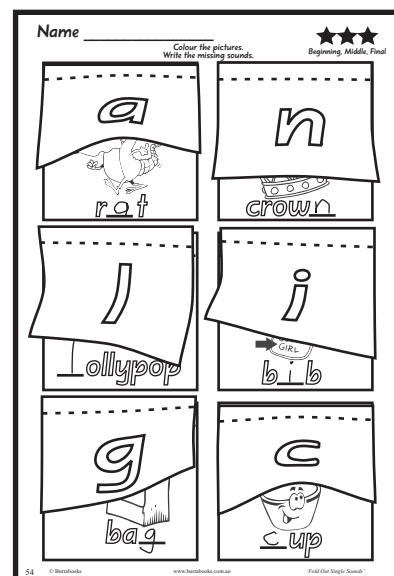

The picture and sound cards can also be used in many other ways e.g.

- The above activity can be completed in reverse by pasting the picture squares onto the sound sheet.
- After the pasting step has been done, all of the cards could be cut up into individual squares. The whole group or class can then sort all the 'a' or 't' pictures etc. and paste them onto one large sheet of paper.

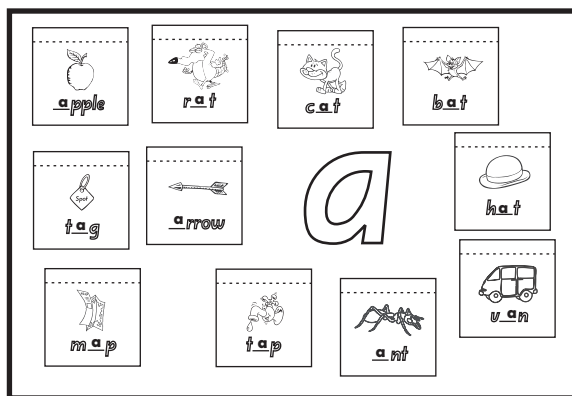

- Multiple copies of each page can be made and the cards can then be used for many types of games e.g. bingo, sound dominoes or concentration. The cards may be coloured by the students and laminated for durability.
- The pages can be made into handy flashcards, or enlarged and used for classroom displays.
- A blank template has been provided at the back of the book to allow the teacher to expand the content or design their own cards.
- The correct handwriting style for each state of Australia has also been provided. These letters can be pasted onto the blank template and then used according to the suggestions above. Most of the letters on the sound pages are suitable for each state, but for those which may be unsuitable the teacher can cut and paste the correct style over the letter to match their requirements.

Name \_\_\_\_\_



Colour the pictures.  
Write the missing sounds.

Beginning sounds.

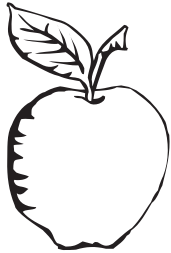

\_\_\_\_\_pple

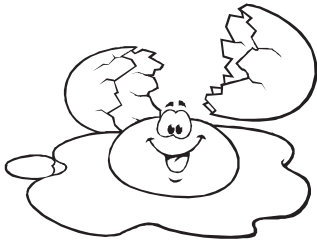

\_\_\_\_\_gg

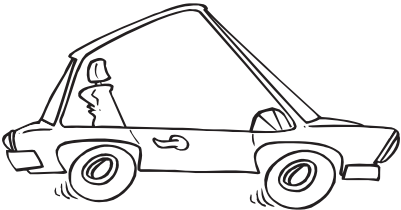

\_\_\_\_\_ar



\_\_\_\_\_ing

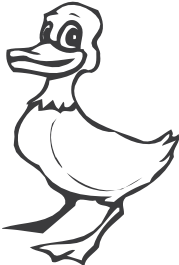

\_\_\_\_\_uck



\_\_\_\_\_amp

Name \_\_\_\_\_

Trace the sounds. Cut out the squares.  
Paste them onto the picture squares.



Beginning sounds.

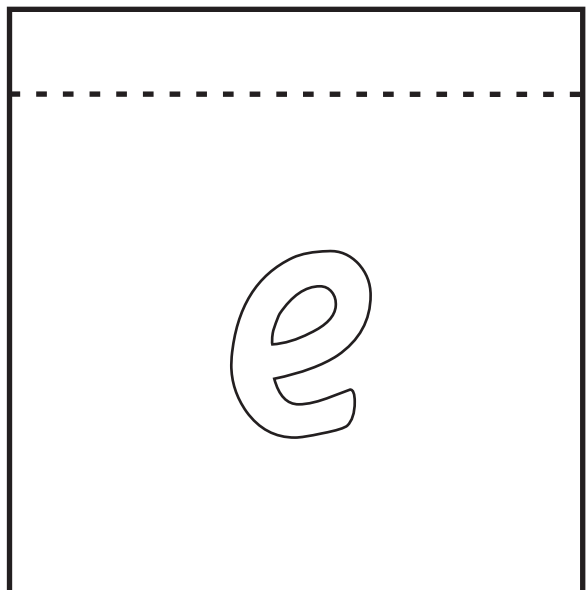
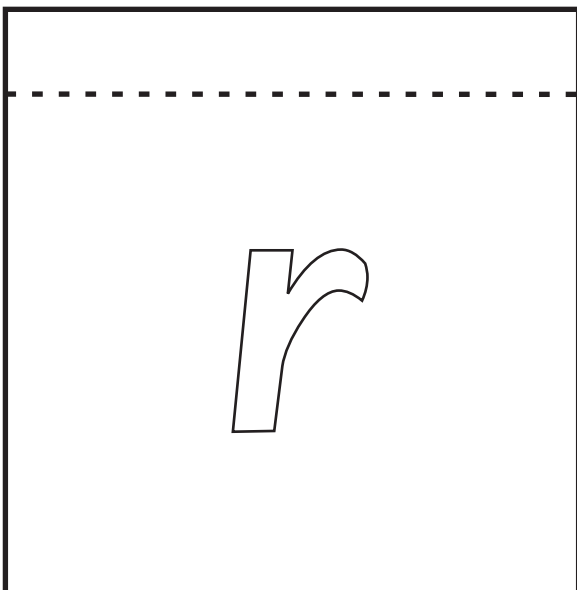
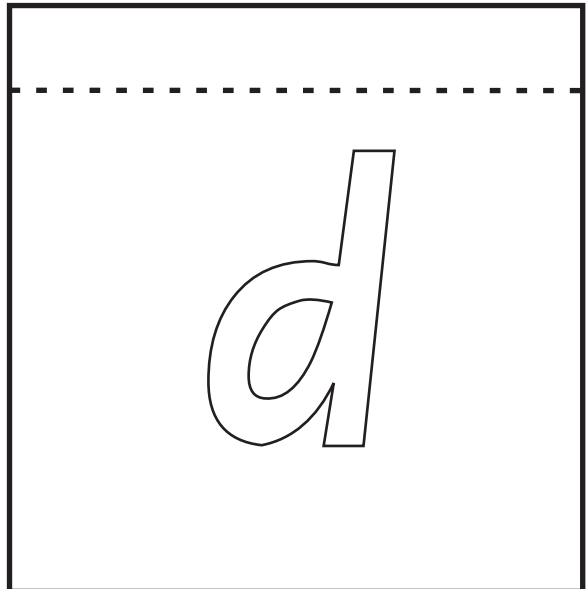
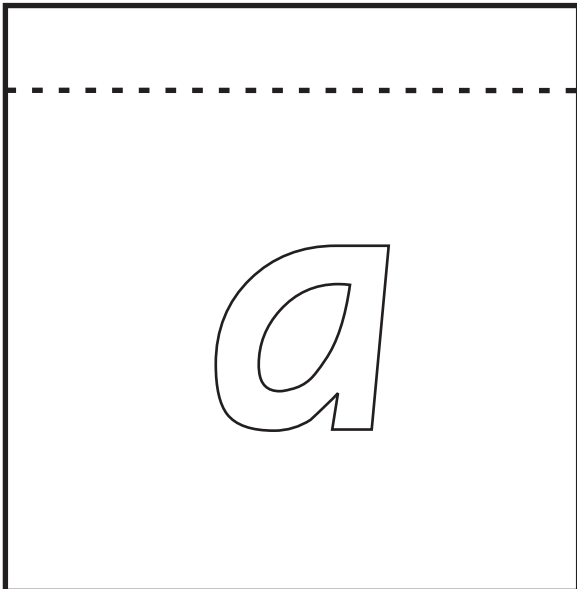
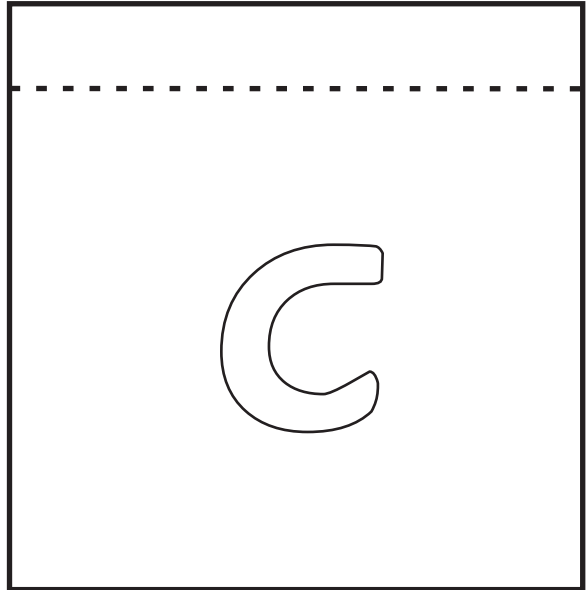
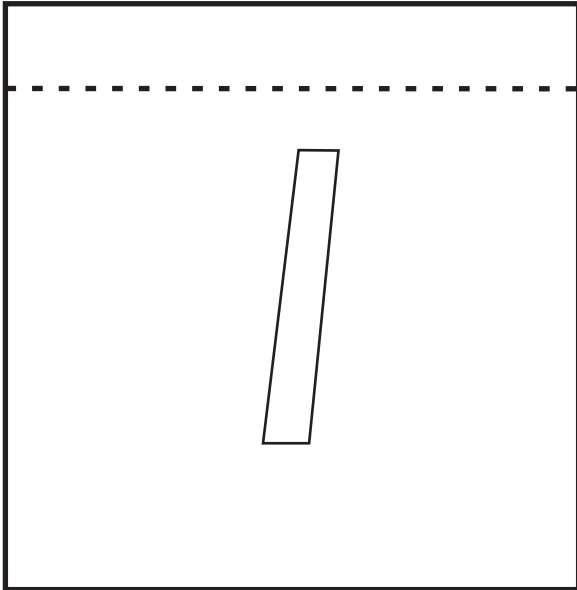

Name \_\_\_\_\_



Colour the pictures.  
Write the missing sounds.

Beginning sounds.

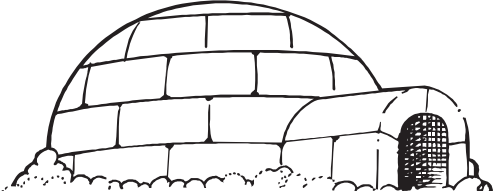

\_\_\_gloo

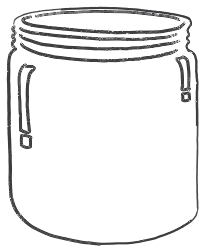

\_\_\_ar

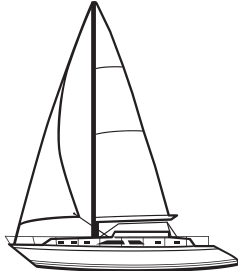

\_\_\_acht



\_\_\_ail



\_\_\_ase

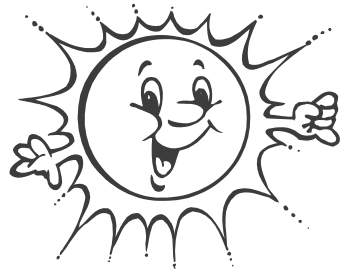

\_\_\_un

Name \_\_\_\_\_

Trace the sounds. Cut out the squares.  
Paste them onto the picture squares.



Beginning sounds.

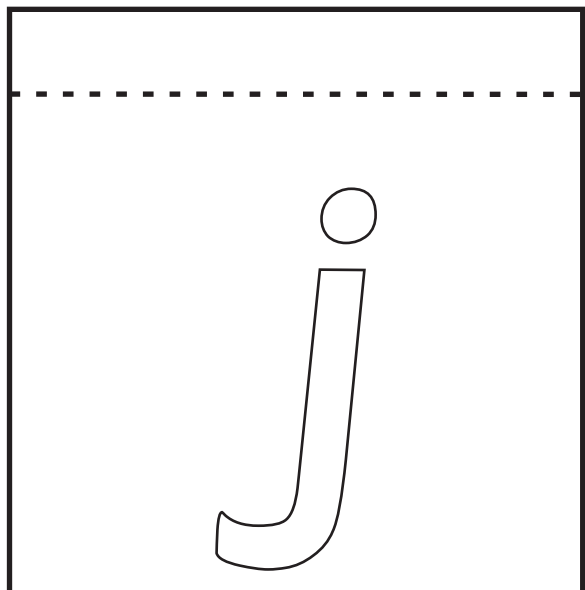
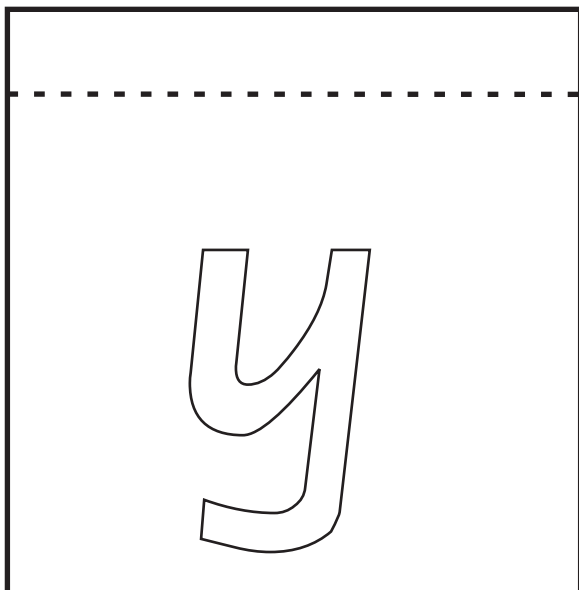
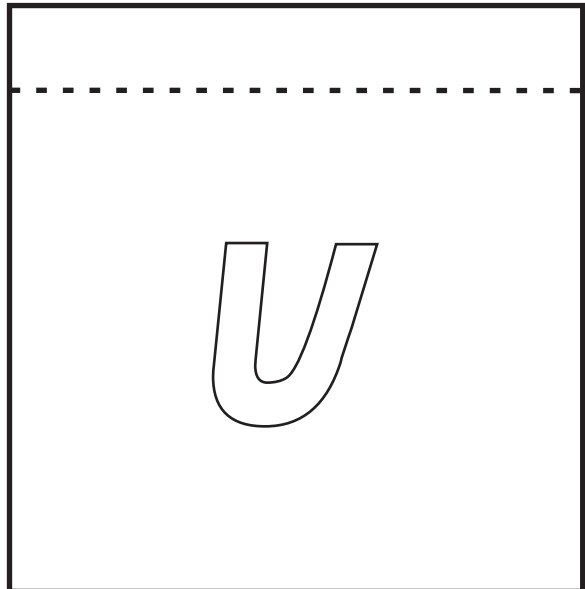
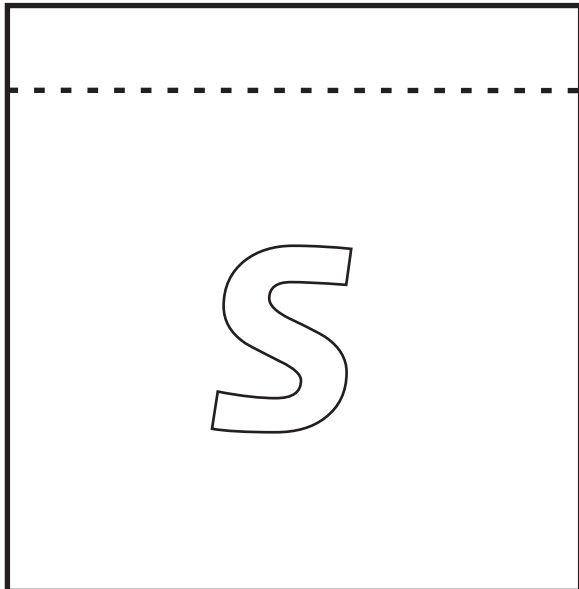
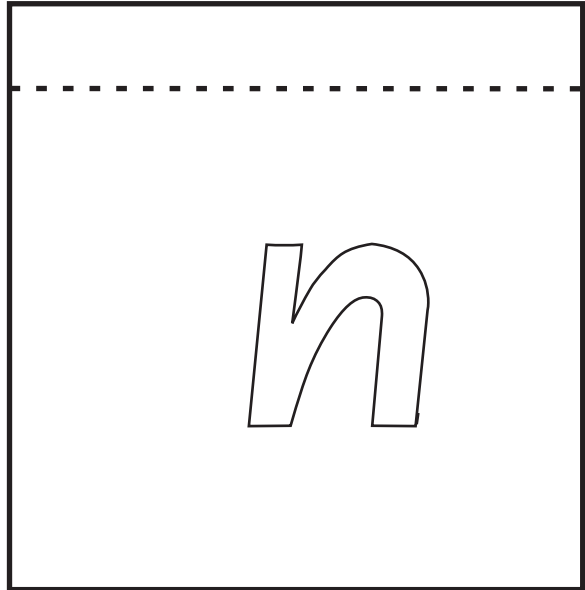
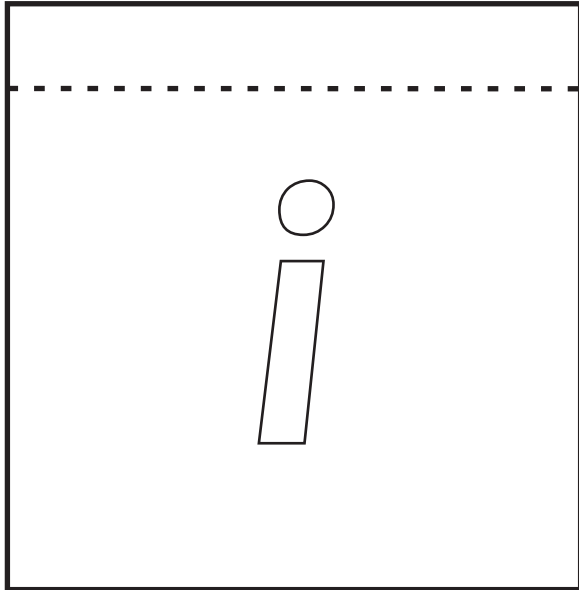



Name \_\_\_\_\_



Colour the pictures.  
Write the missing sounds.

Beginning sounds.



\_\_\_ot



\_\_\_an

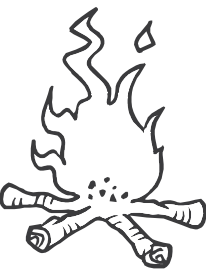

\_\_\_ire



\_\_\_and

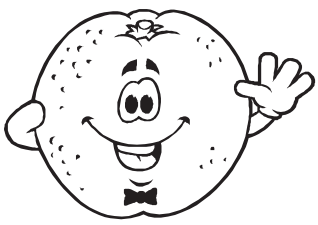

\_\_\_range

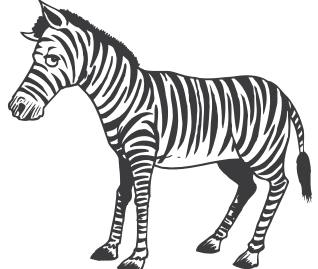

\_\_\_ebra

Name \_\_\_\_\_

Trace the sounds. Cut out the squares.  
Paste them onto the picture squares.



Beginning sounds.

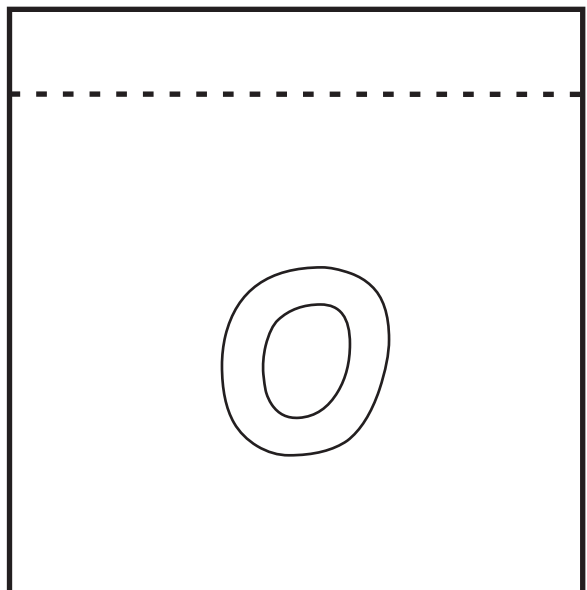
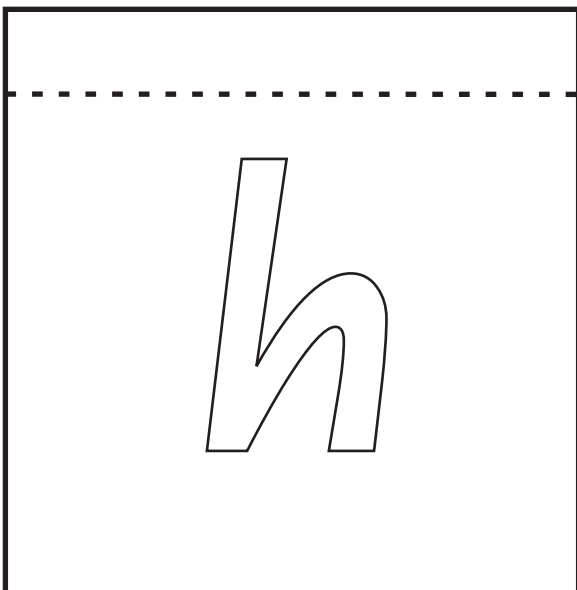
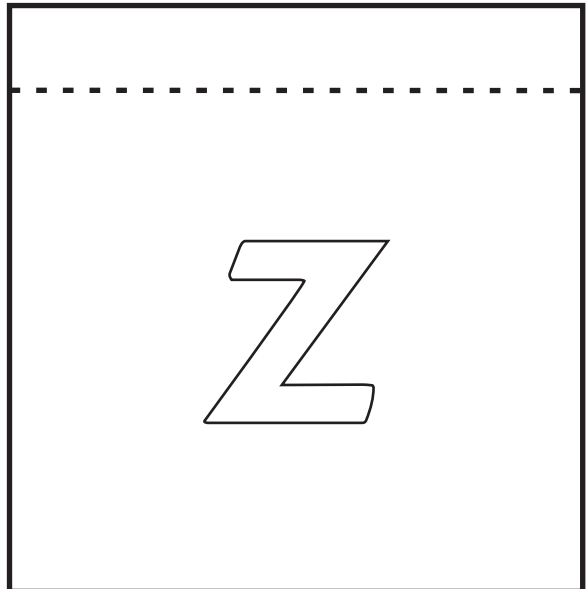
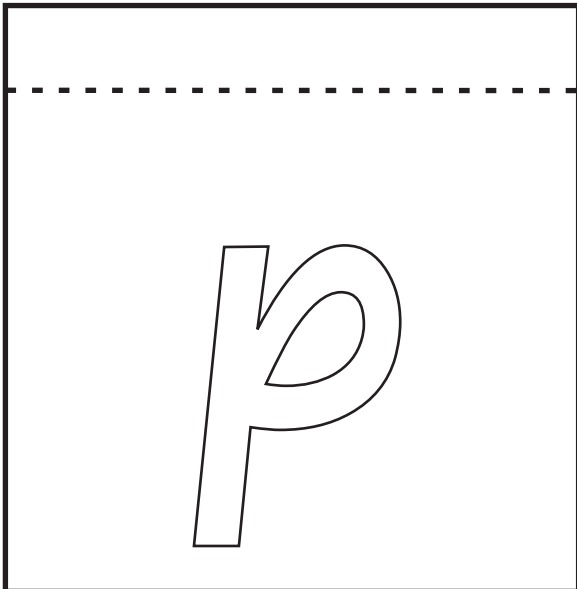
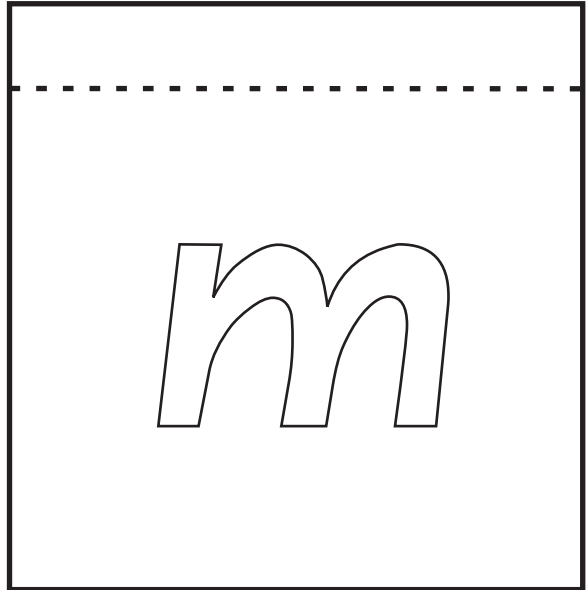
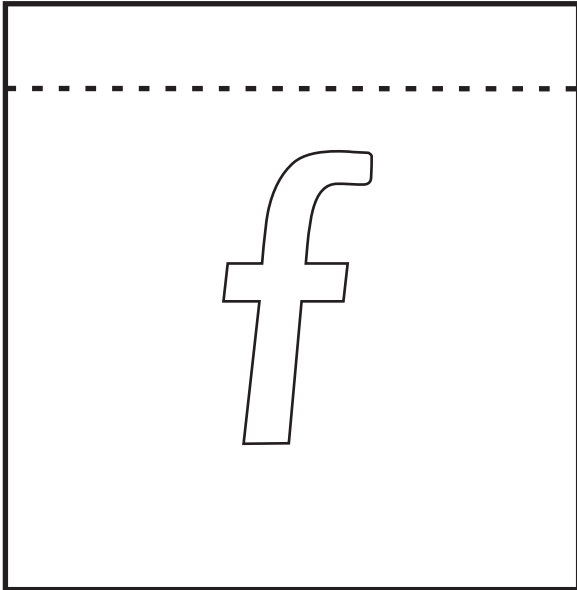

Name \_\_\_\_\_



Colour the pictures.  
Write the missing sounds.

Beginning sounds.



\_\_irl

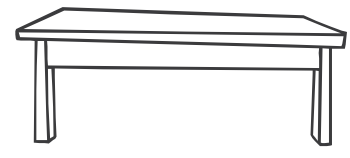

\_\_able

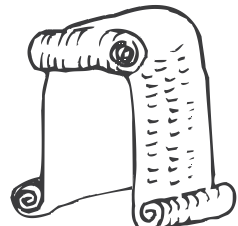

\_\_ig

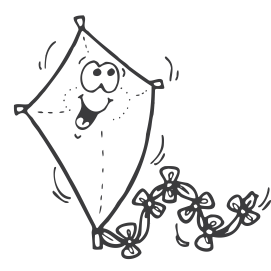

\_\_ite

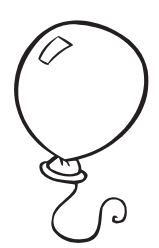

\_\_alloon

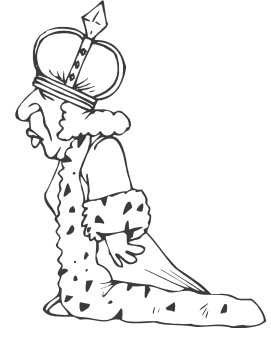

\_\_ueen

Name \_\_\_\_\_

Trace the sounds. Cut out the squares.  
Paste them onto the picture squares.



Beginning sounds.

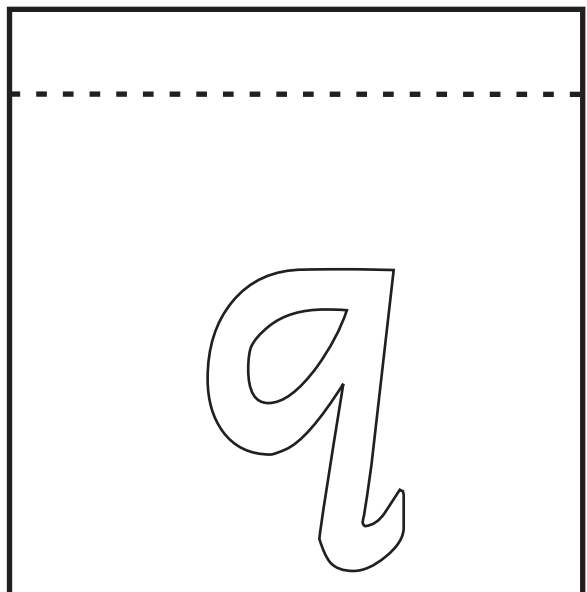
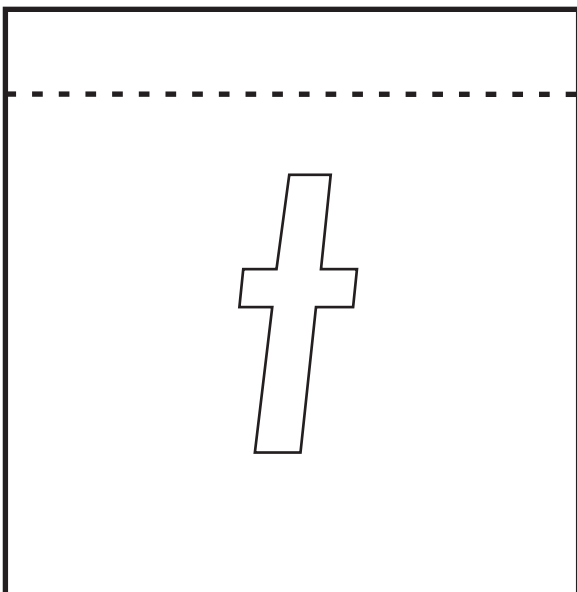
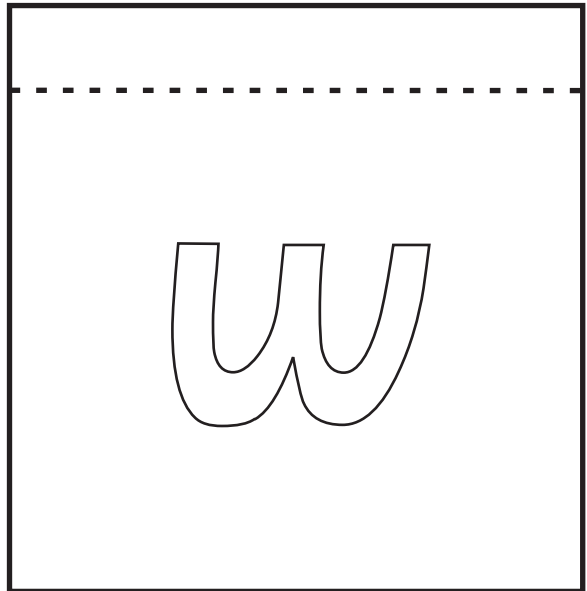
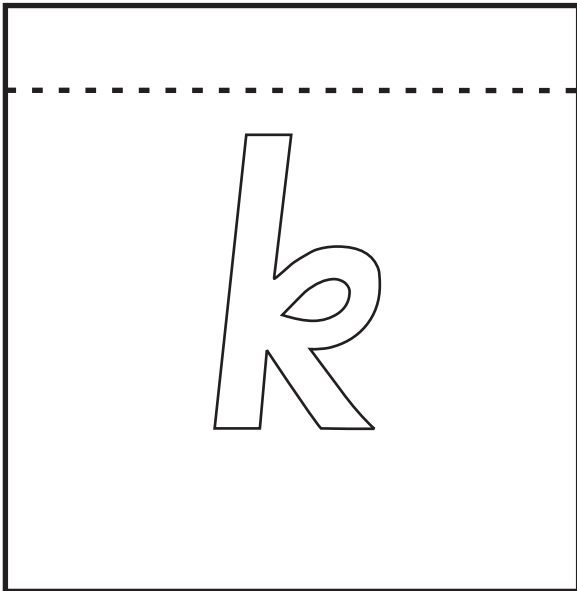
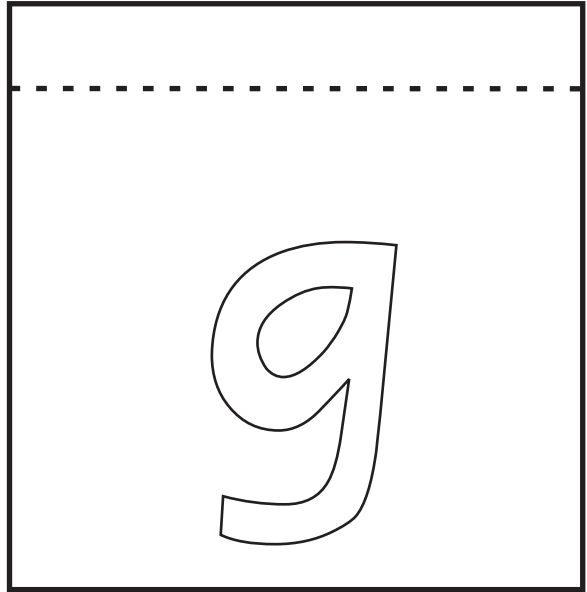
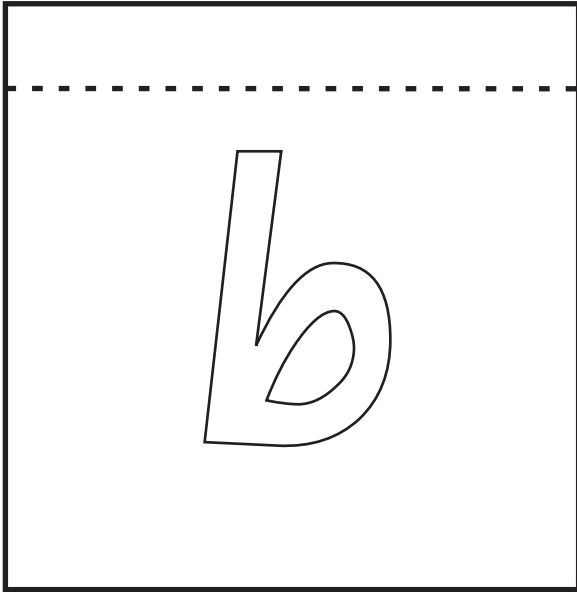

Name \_\_\_\_\_



Colour the pictures.  
Write the missing sounds.

Beginning sounds.



\_\_\_ee

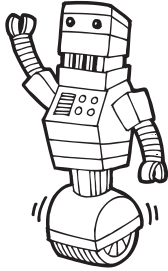

\_\_\_obot



\_\_\_mbrella



\_\_\_oala



\_\_\_orse



\_\_\_-ray

Name \_\_\_\_\_

Trace the sounds. Cut out the squares.  
Paste them onto the picture squares.



Beginning sounds.

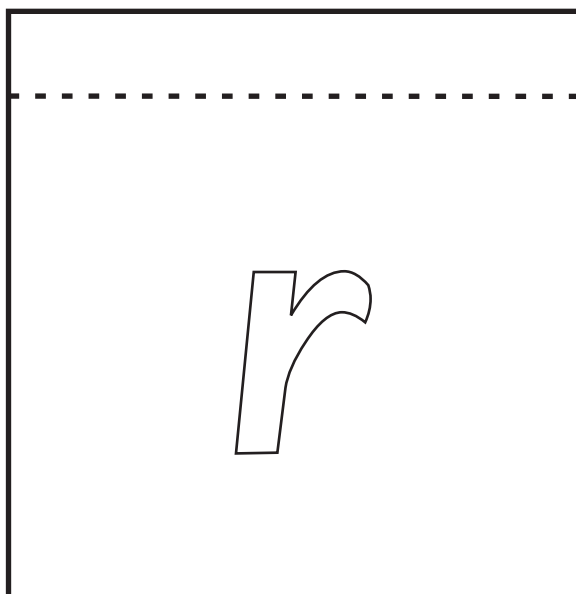
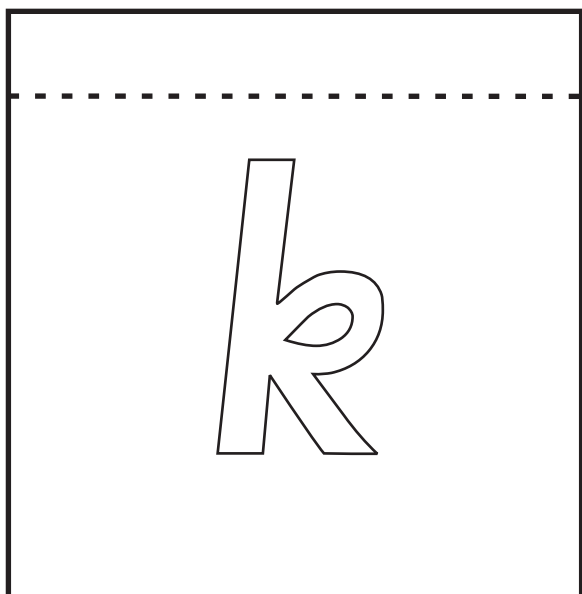
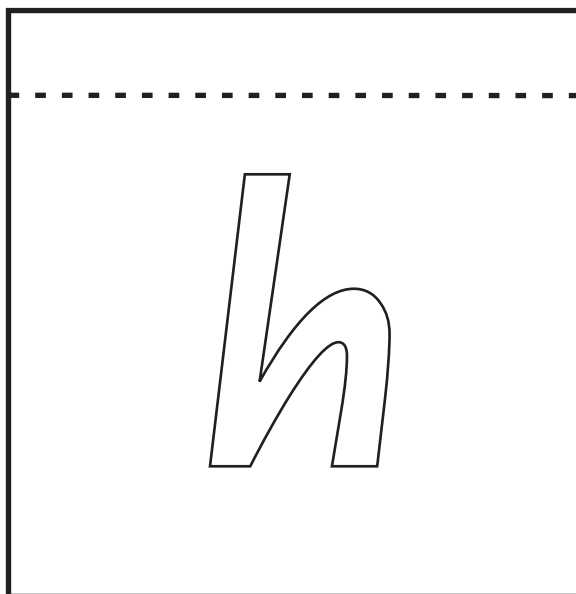
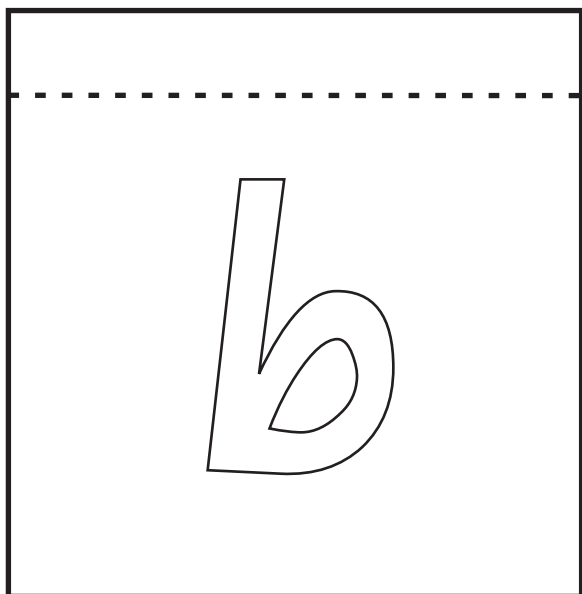
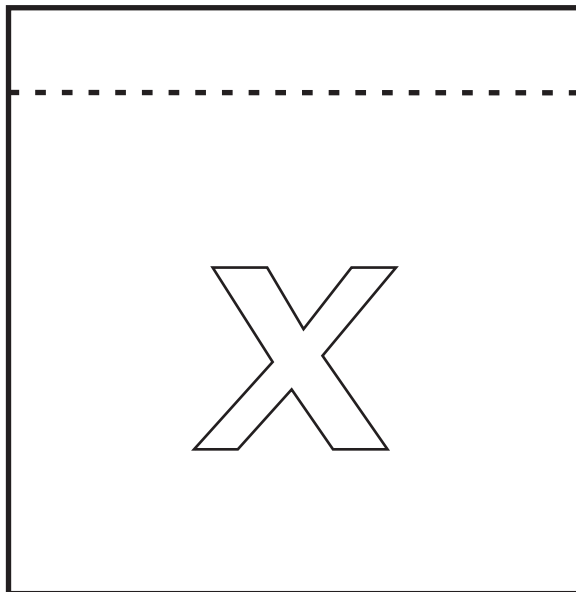
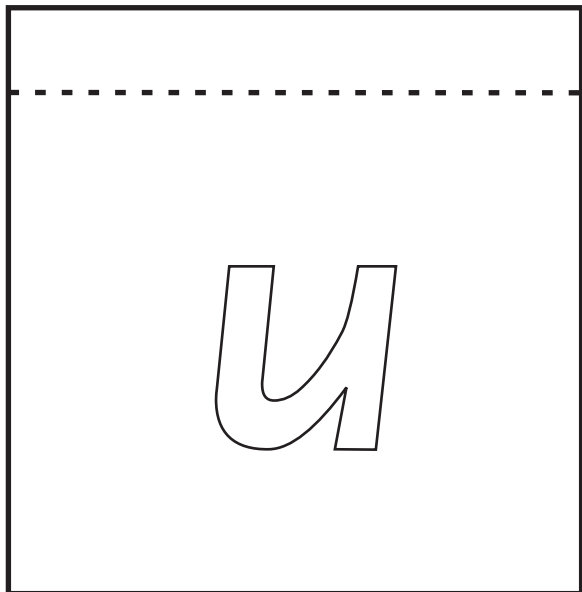

Name \_\_\_\_\_



Colour the pictures.  
Write the missing sounds.

Beginning sounds.



\_\_\_ot dog

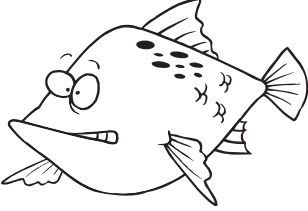

\_\_\_ish

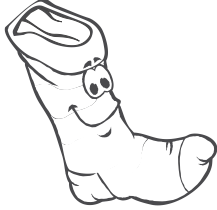

\_\_\_ock

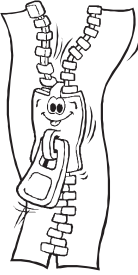

\_\_\_ipper

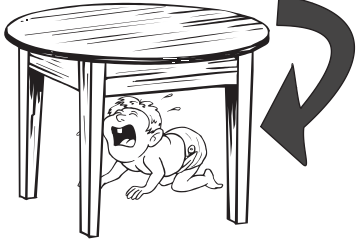

\_\_\_nder



\_\_\_nt

Name \_\_\_\_\_

Trace the sounds. Cut out the squares.  
Paste them onto the picture squares.



Beginning sounds.

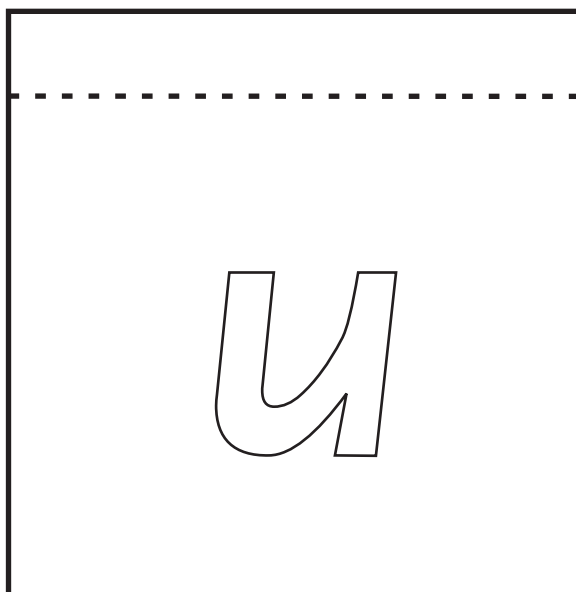
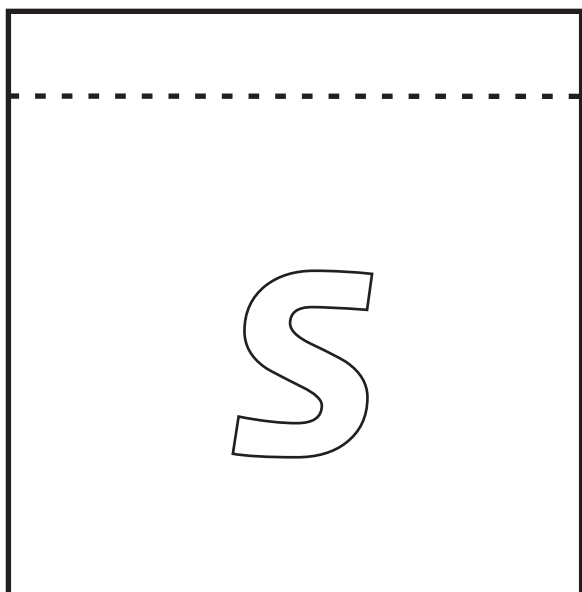
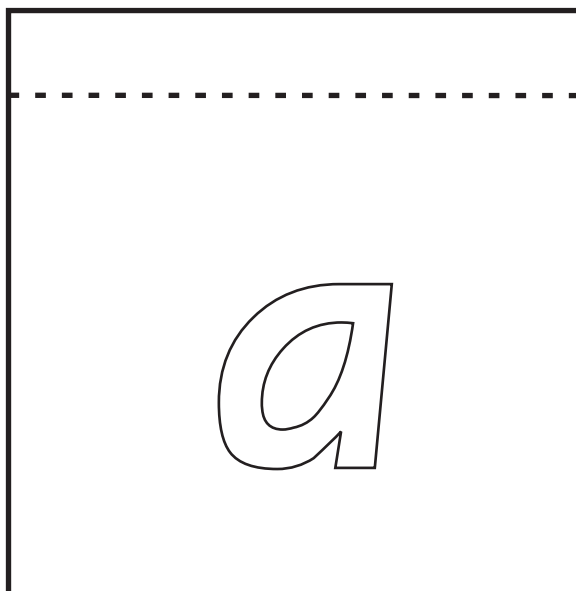
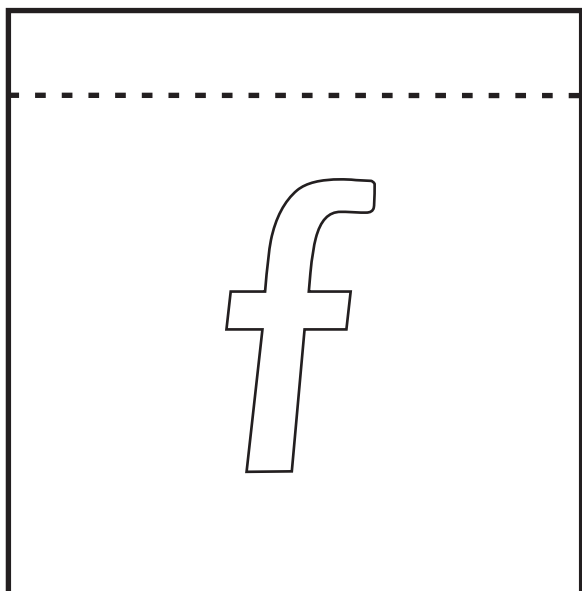
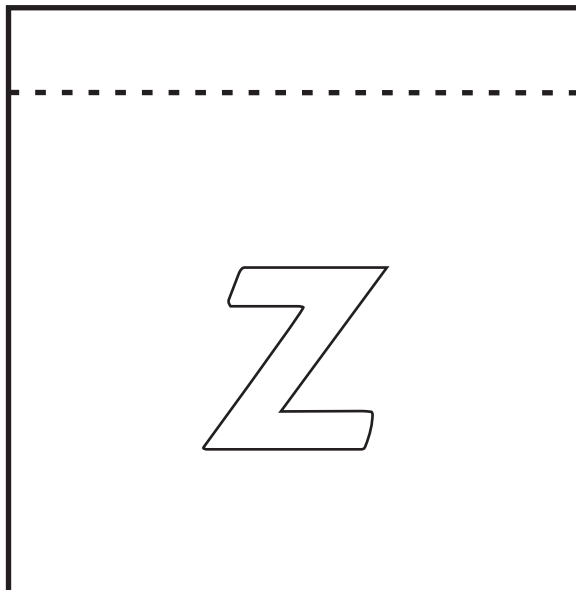
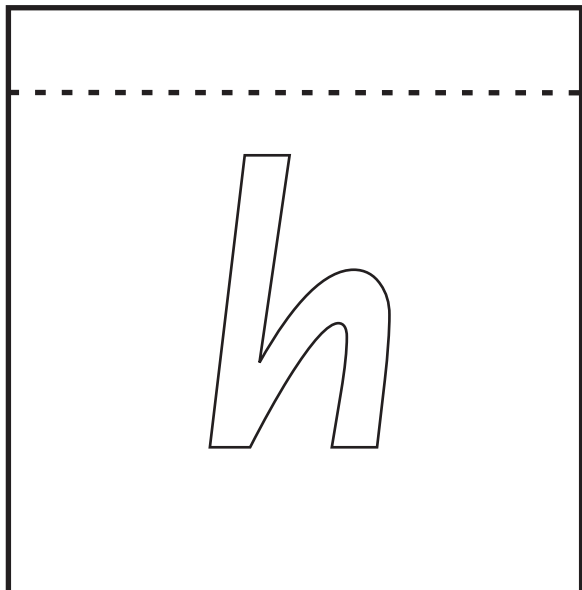



Name \_\_\_\_\_



Colour the pictures.  
Write the missing sounds.

Beginning sounds.

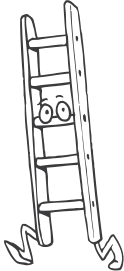

\_\_adder



\_\_est



\_\_atch

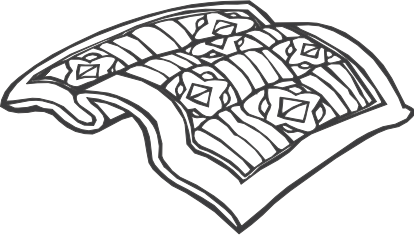

\_\_uilt



\_\_nsects

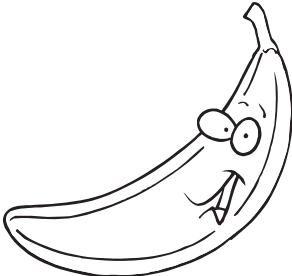

\_\_anana

Name \_\_\_\_\_

Trace the sounds. Cut out the squares.  
Paste them onto the picture squares.



Beginning sounds.

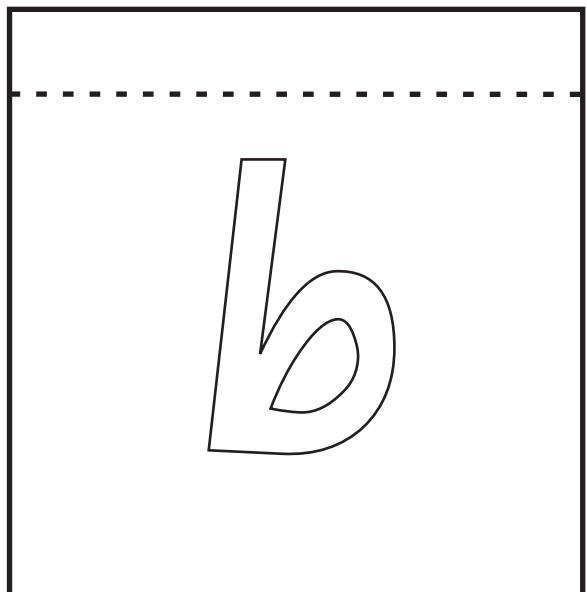
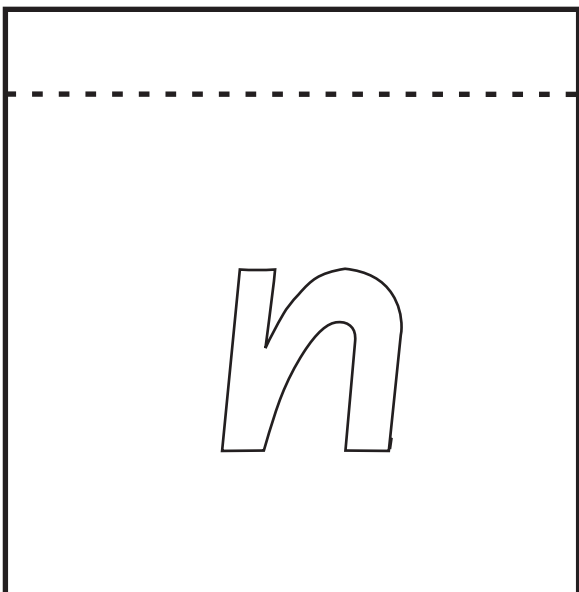
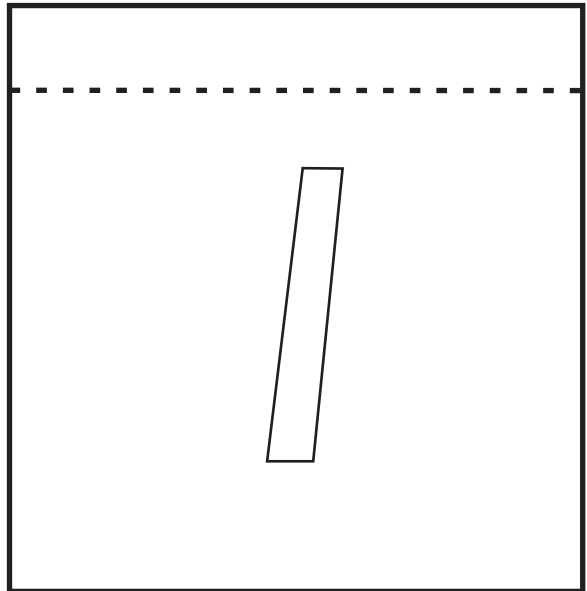
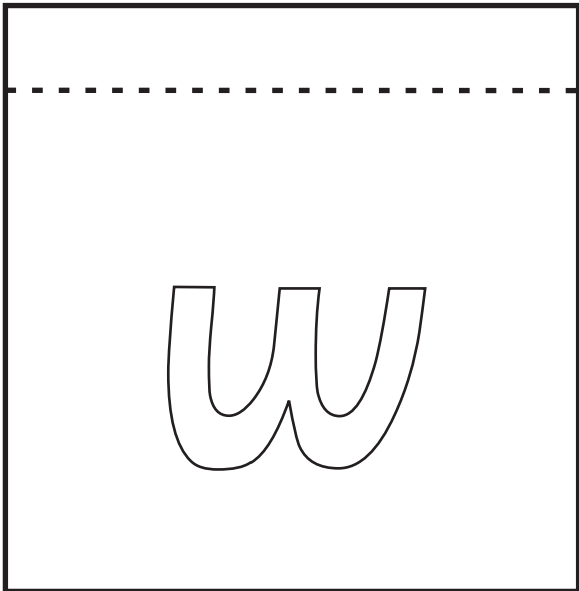
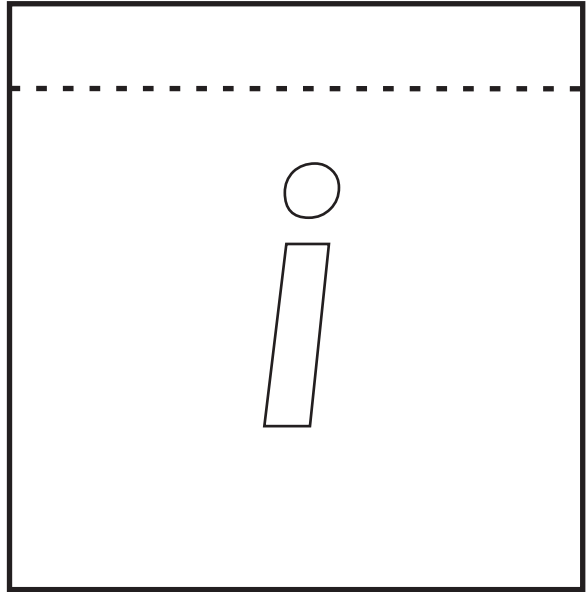
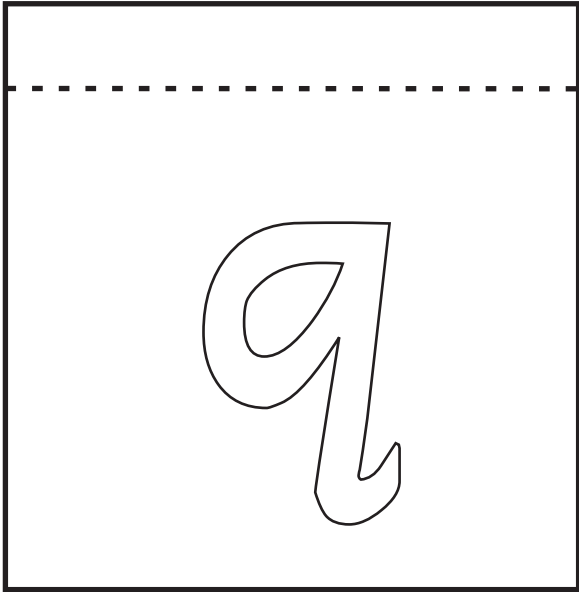

Name \_\_\_\_\_



Colour the pictures.  
Write the missing sounds.

Beginning sounds.

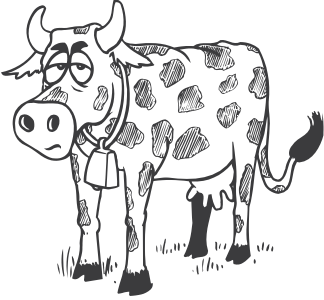

\_\_\_ow



\_\_\_iss

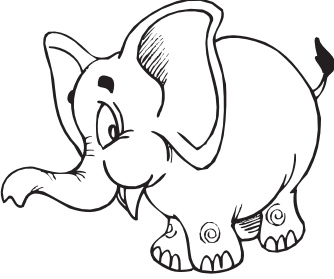

\_\_\_lephant

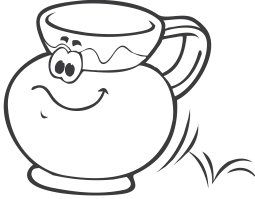

\_\_\_ug

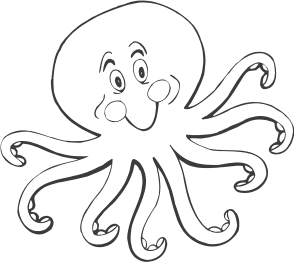

\_\_\_ctopus



\_\_\_awn

Name \_\_\_\_\_

Trace the sounds. Cut out the squares.  
Paste them onto the picture squares.



Beginning sounds.

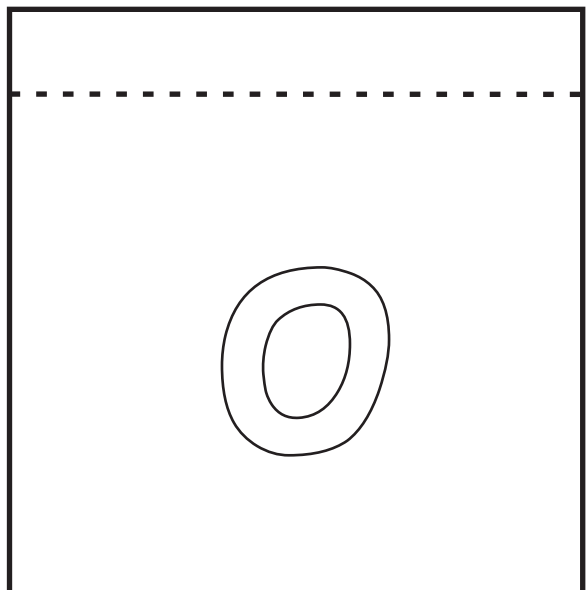
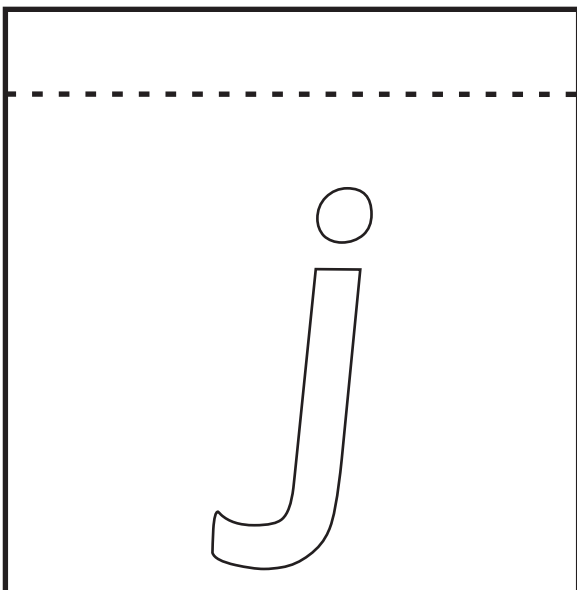
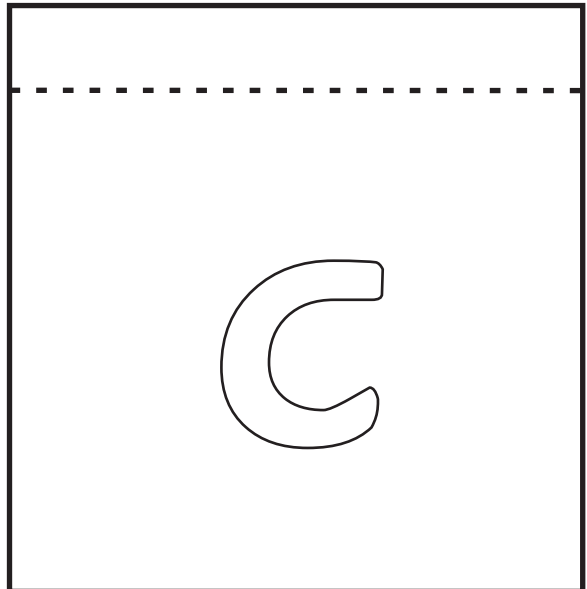
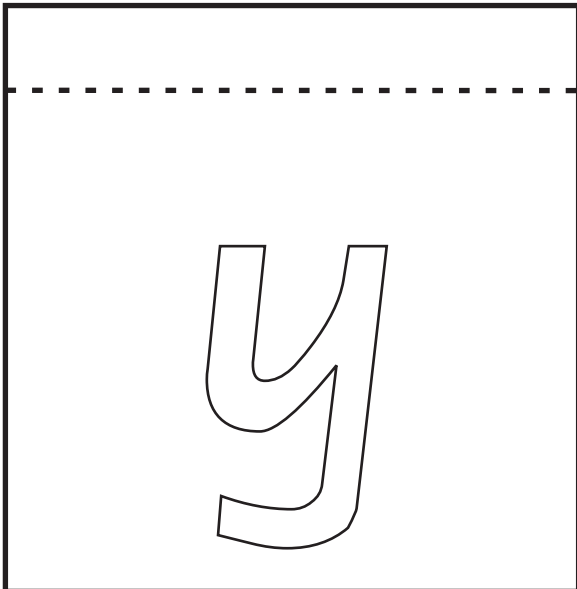
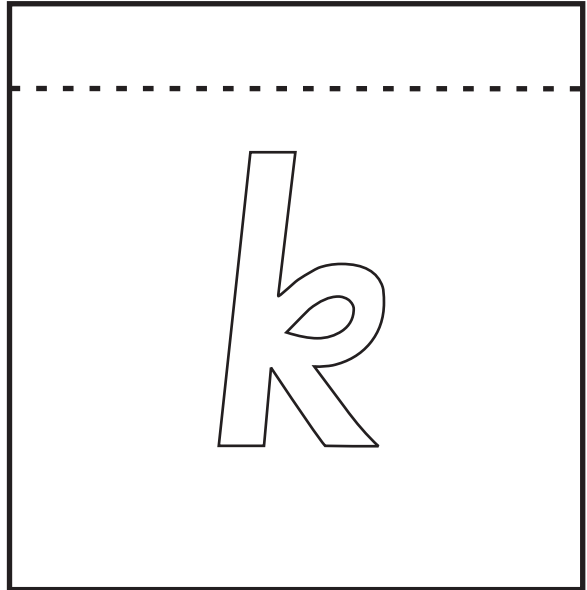
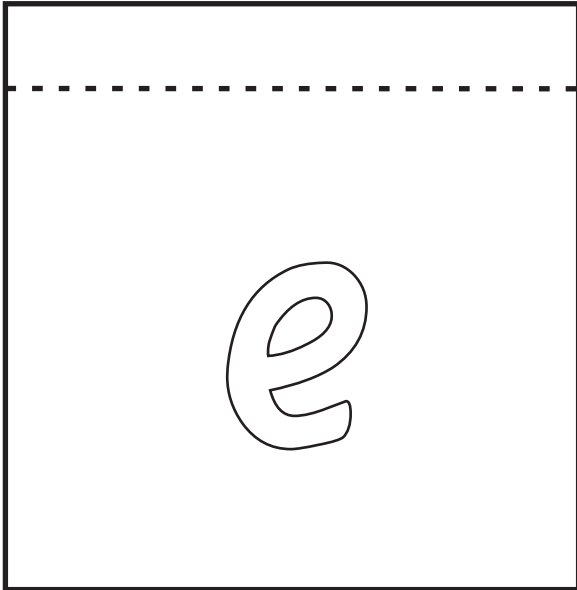

Name \_\_\_\_\_



Colour the pictures.  
Write the missing sounds.

Beginning sounds.



\_\_\_ap

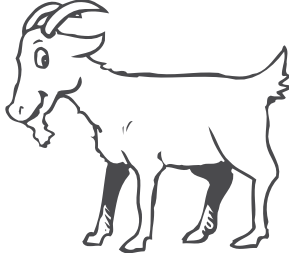

\_\_\_oat



\_\_\_ive

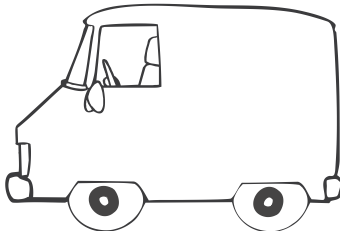

\_\_\_an

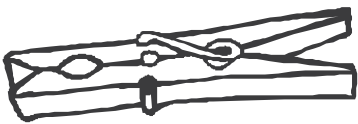

\_\_\_eg



\_\_\_ocks

Name \_\_\_\_\_

Trace the sounds. Cut out the squares.  
Paste them onto the picture squares.



Beginning sounds.

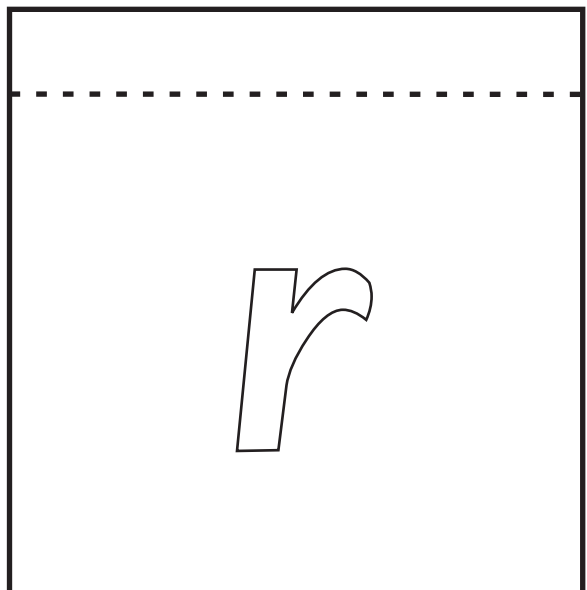
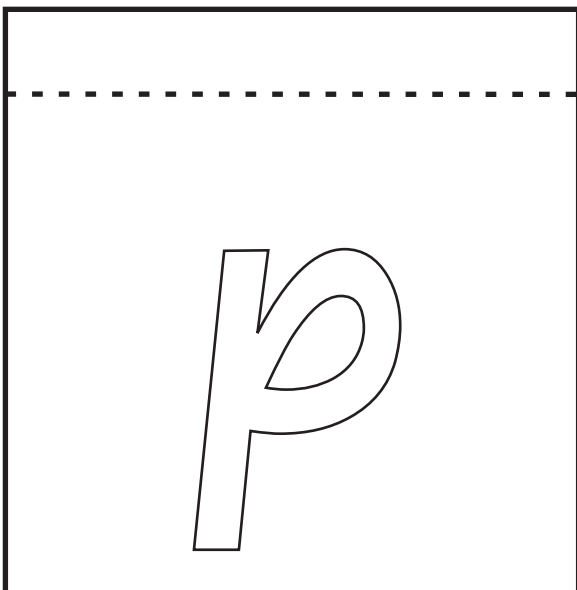
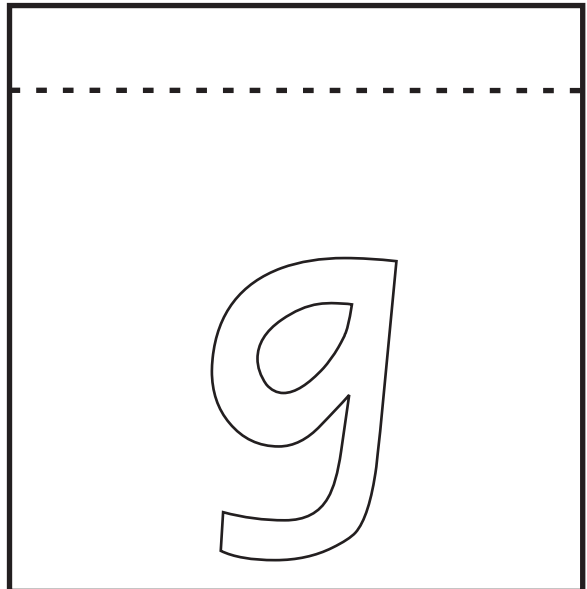
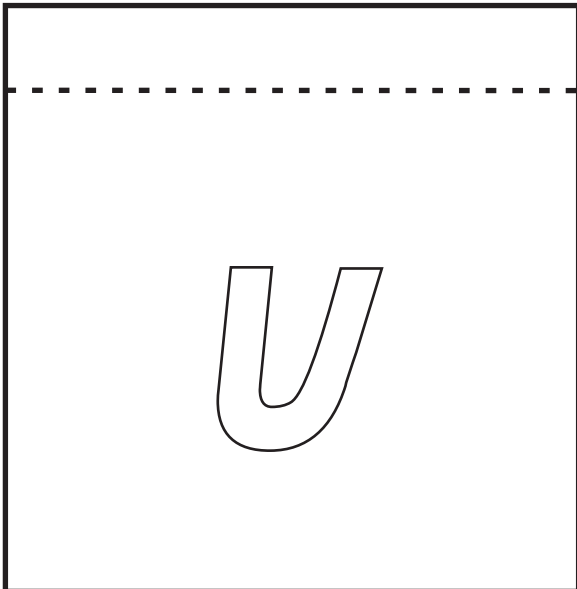
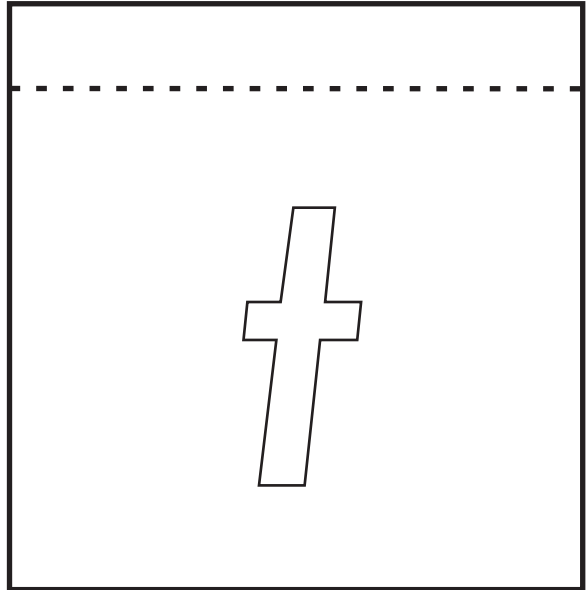
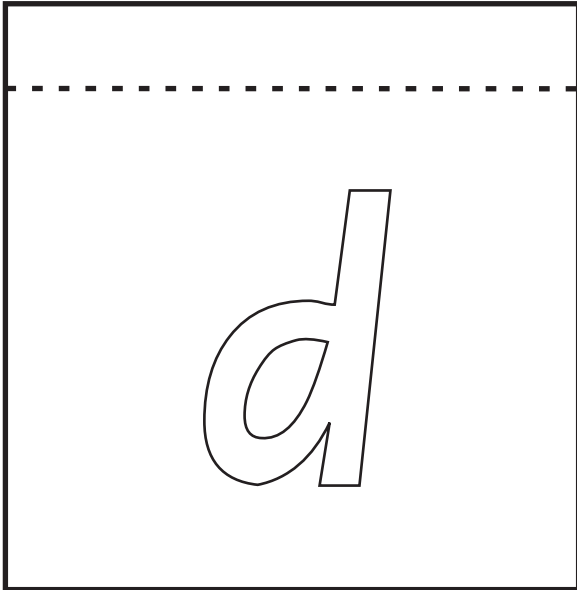

Name \_\_\_\_\_



Colour the pictures.  
Write the missing sounds.

Beginning sounds.

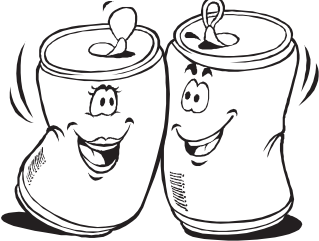

\_\_\_ans

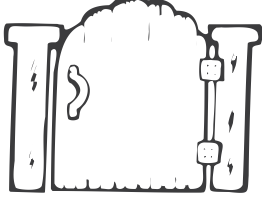

\_\_\_ate

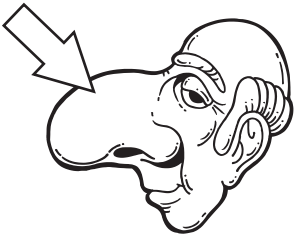

\_\_\_ose

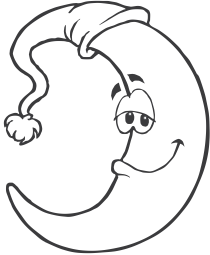

\_\_\_oon



\_\_\_iger

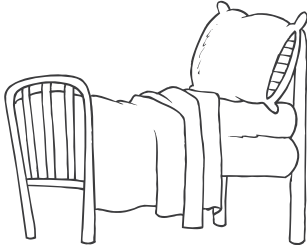

\_\_\_ed

Name \_\_\_\_\_

Trace the sounds. Cut out the squares.  
Paste them onto the picture squares.



Beginning sounds.

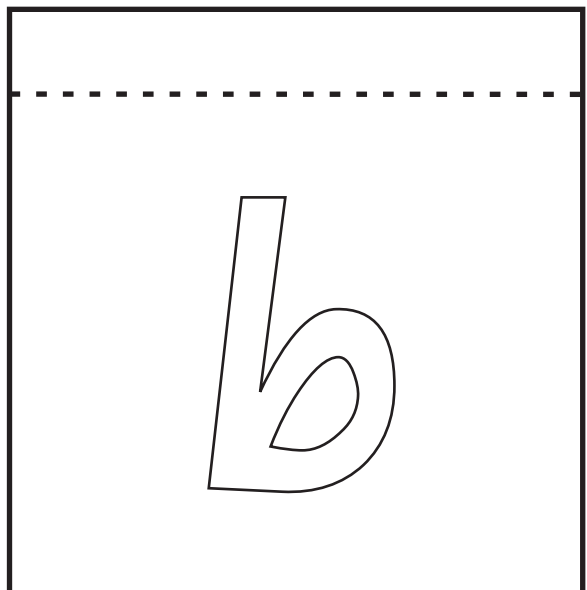
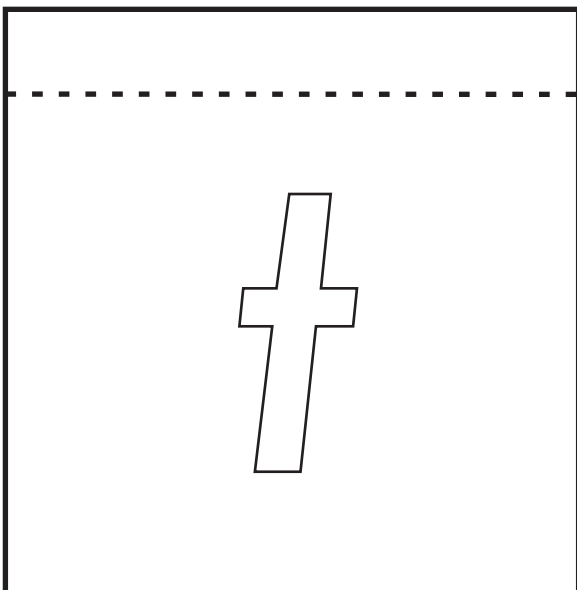
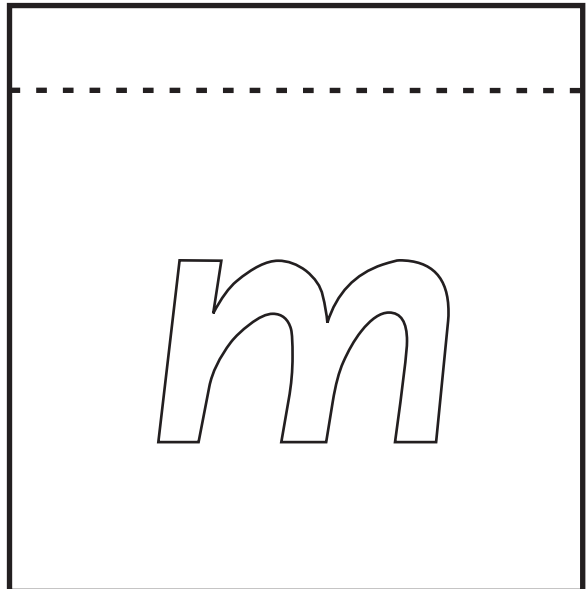
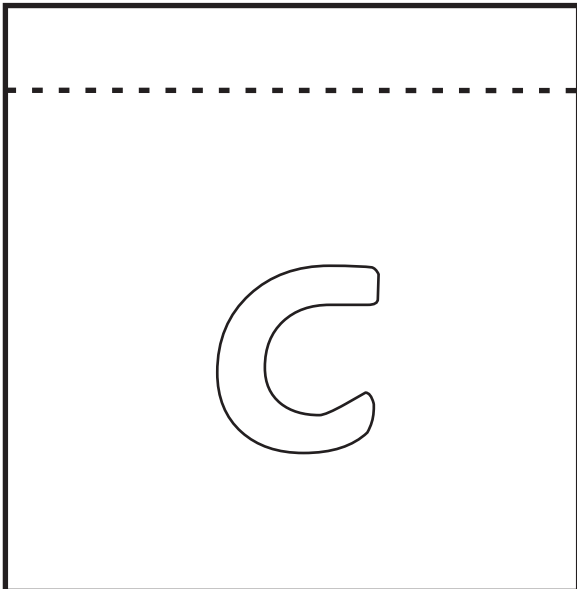
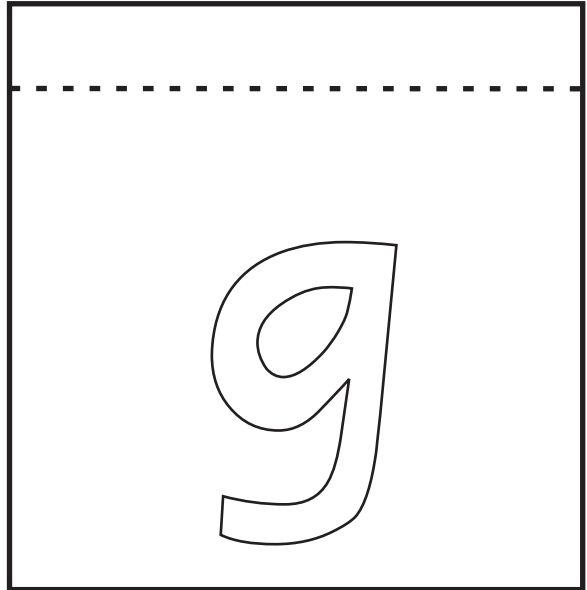
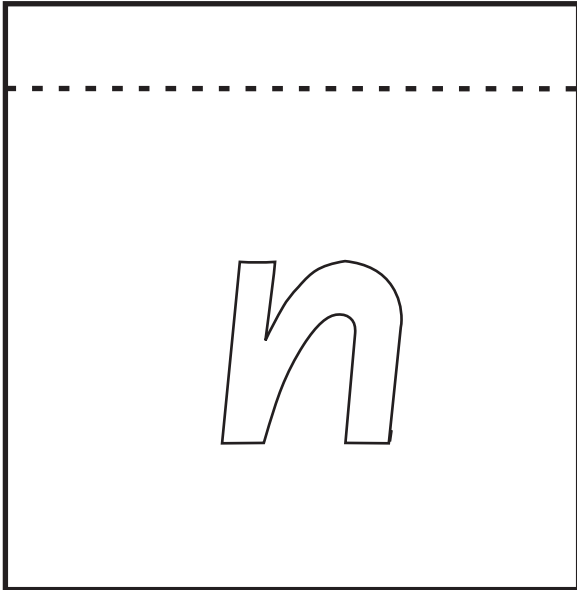



Name \_\_\_\_\_



Colour the pictures.  
Write the missing sounds.

Middle sounds.



f \_ x

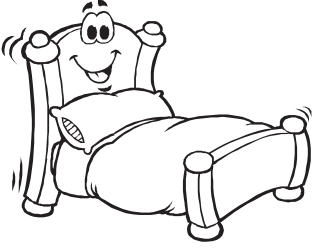

b \_ d



p \_ t

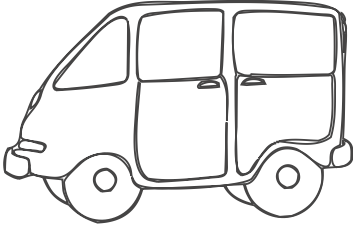

u \_ n

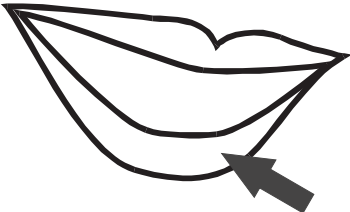

l \_ p

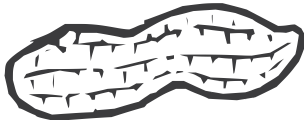

n \_ t

Name \_\_\_\_\_



Trace the sounds. Cut out the squares.  
Paste them onto the picture squares.

Middle sounds.

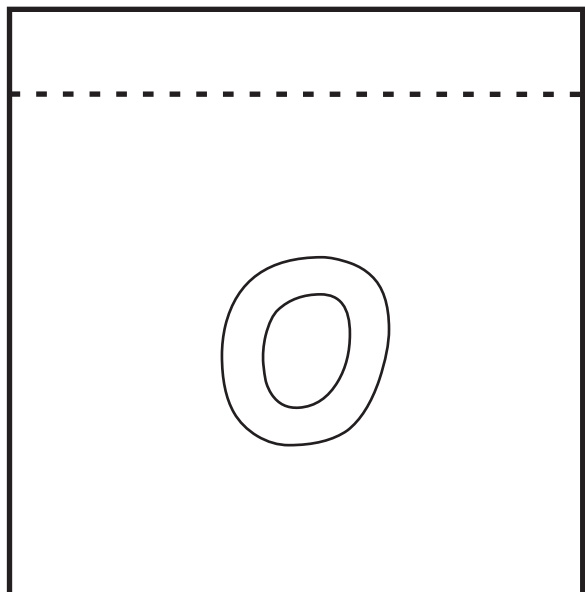
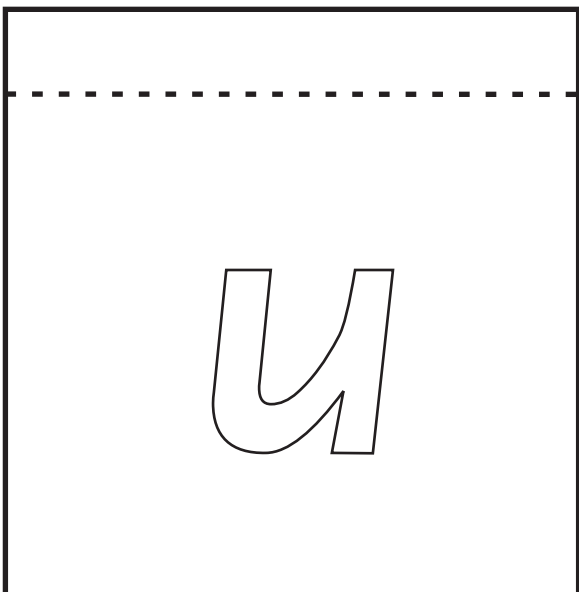
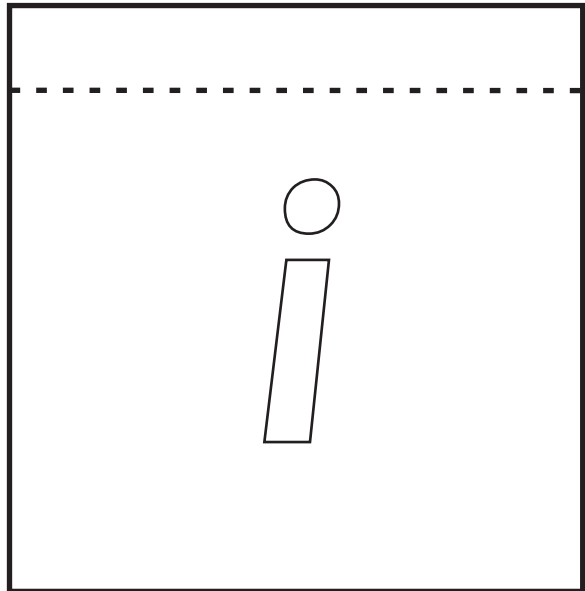
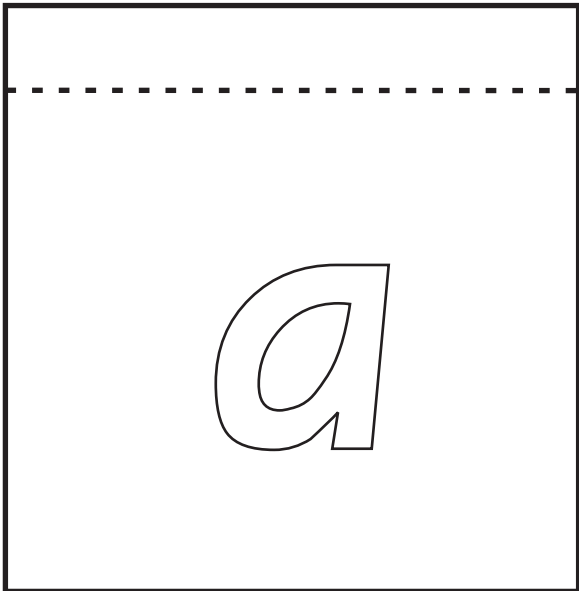
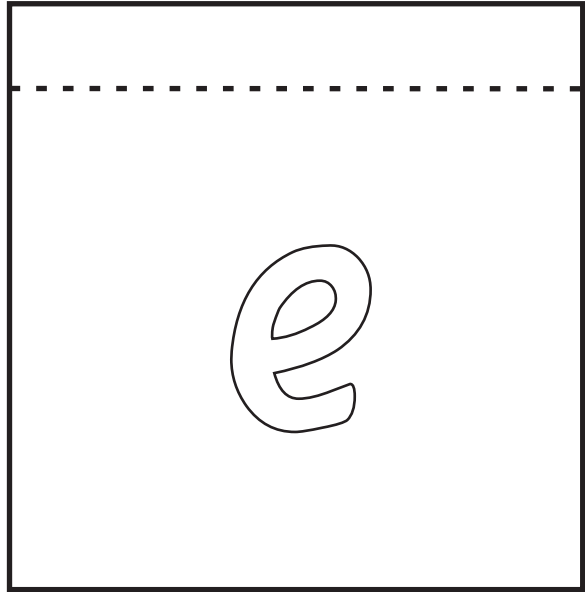
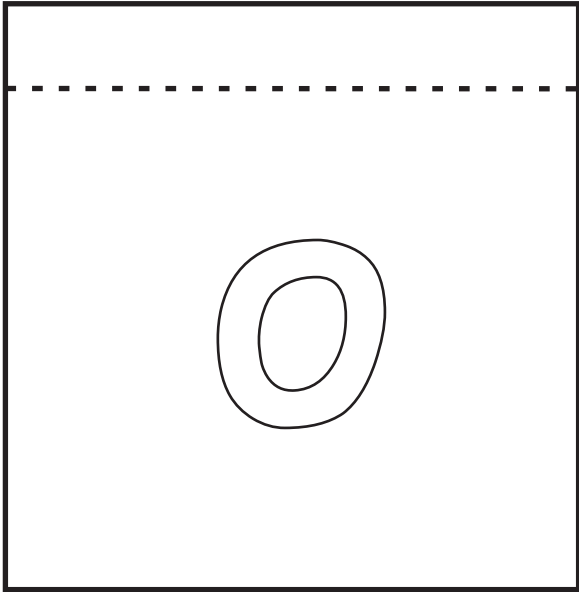

Name \_\_\_\_\_



Colour the pictures.  
Write the missing sounds.

Middle sounds.

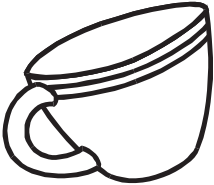

c \_ p

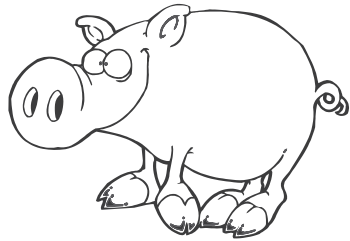

p \_ g

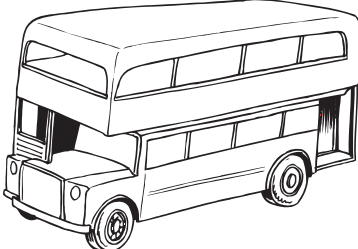

b \_ s

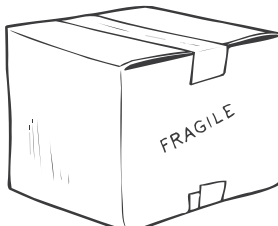

b \_ x



b \_ ll

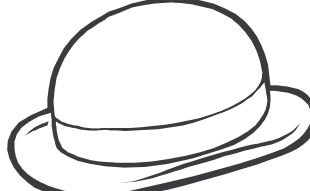

h \_ t

Name \_\_\_\_\_



Trace the sounds. Cut out the squares.  
Paste them onto the picture squares.

Middle sounds.

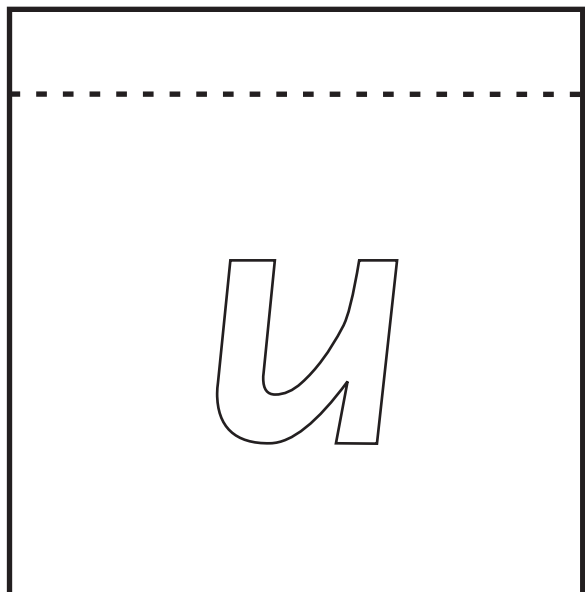
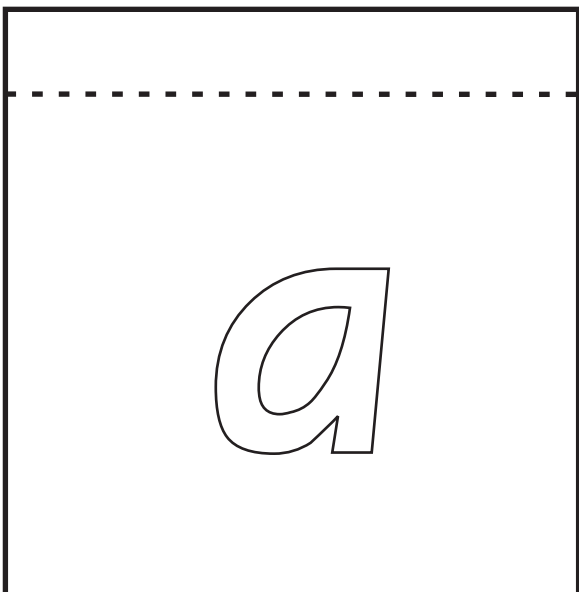
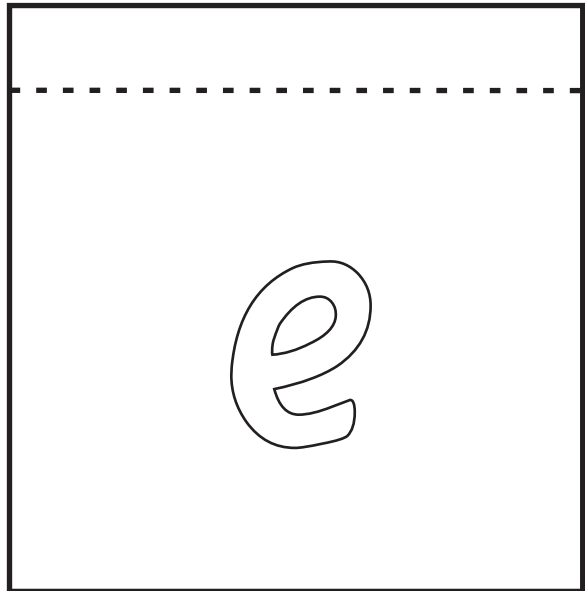
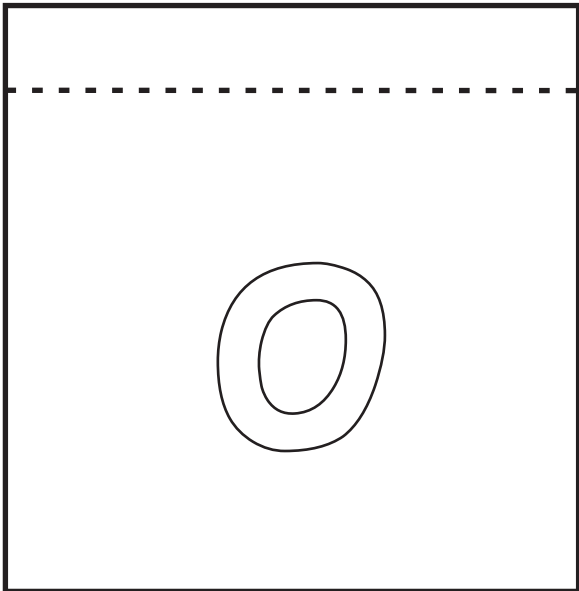
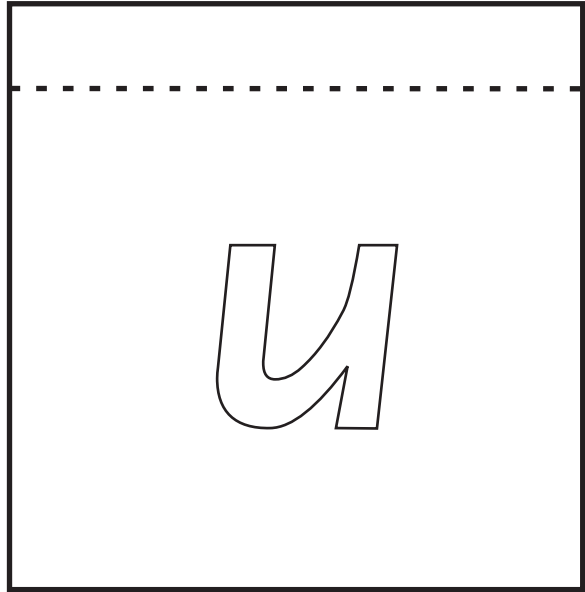
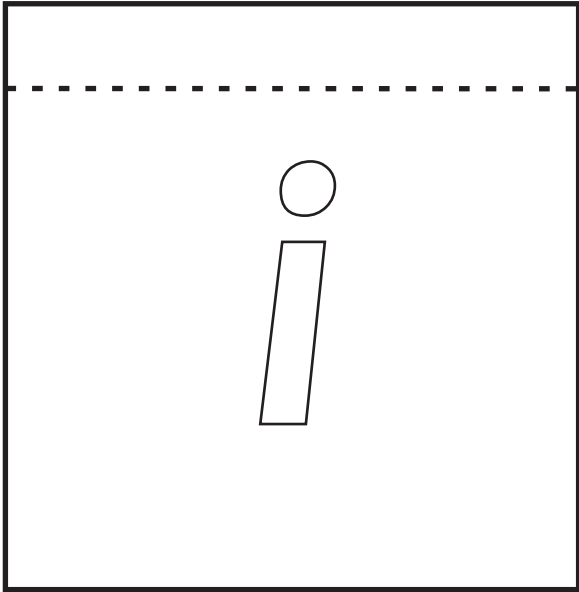

Name \_\_\_\_\_



Colour the pictures.  
Write the missing sounds.

Middle sounds.



f \_ n

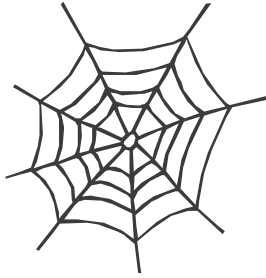

w \_ b

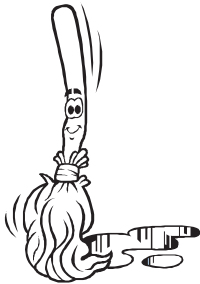

m \_ p



b \_ t

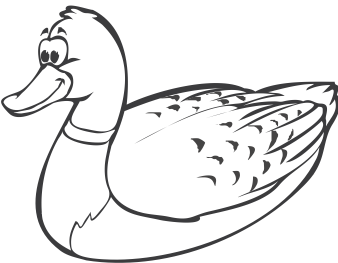

d \_ ck

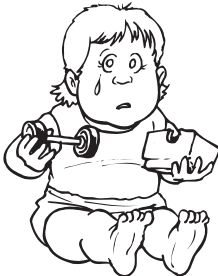

s \_ b

Name \_\_\_\_\_



Trace the sounds. Cut out the squares.  
Paste them onto the picture squares.

Middle sounds.

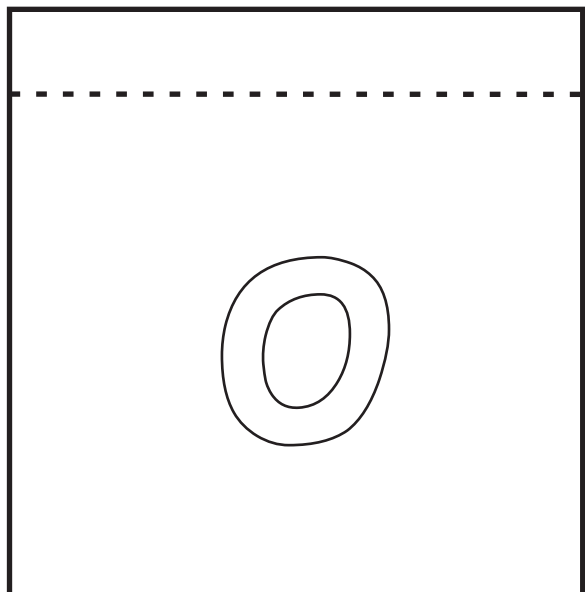
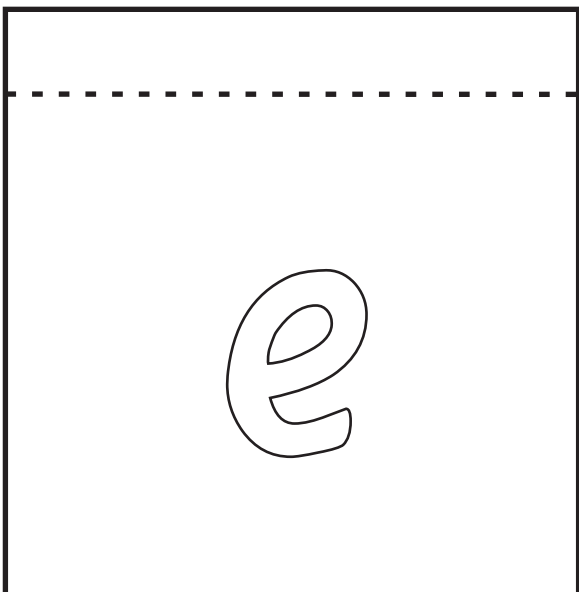
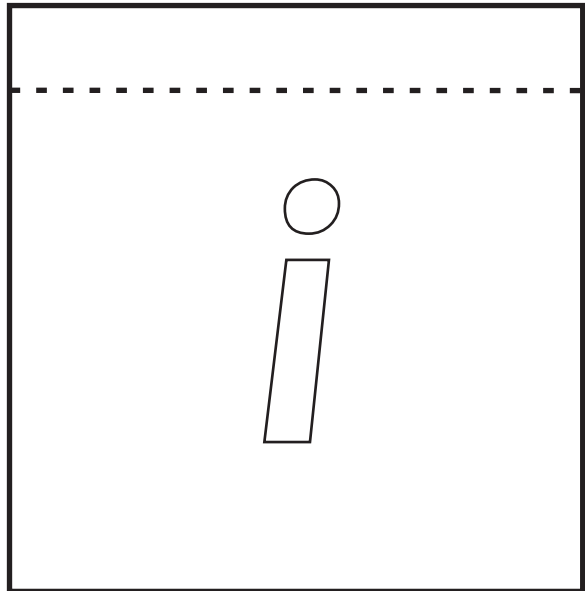
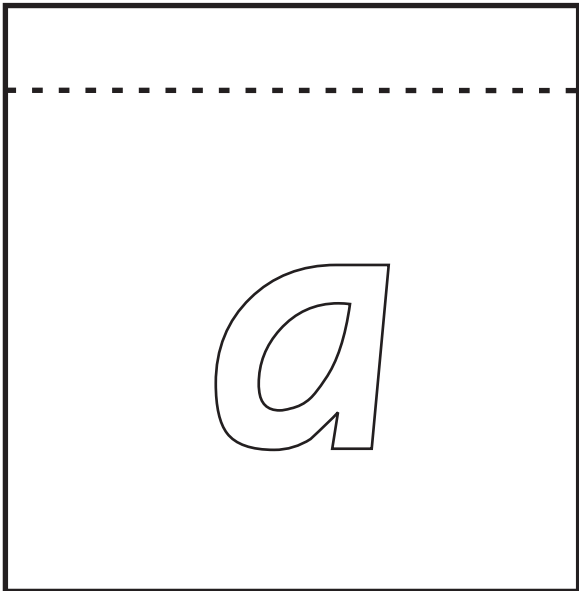
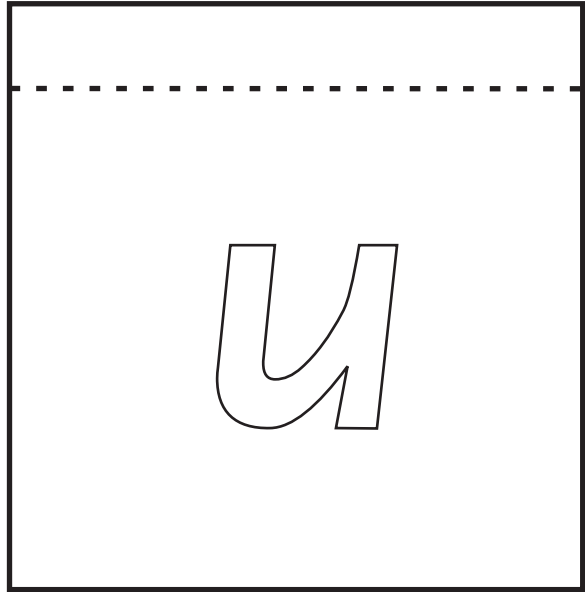
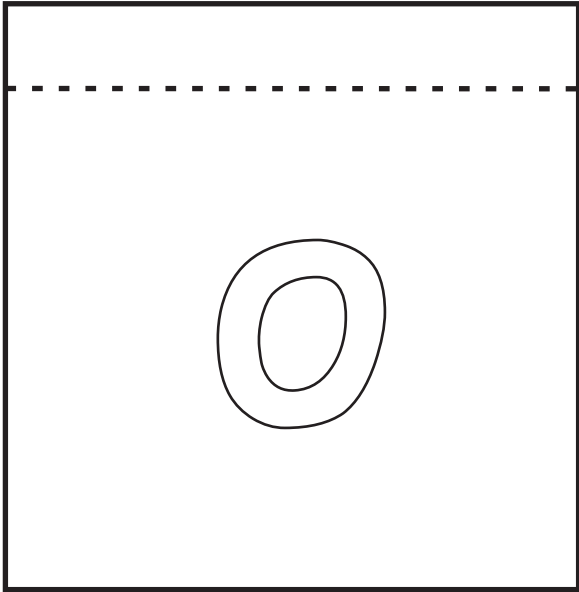

Name \_\_\_\_\_



Colour the pictures.  
Write the missing sounds.

Middle sounds.

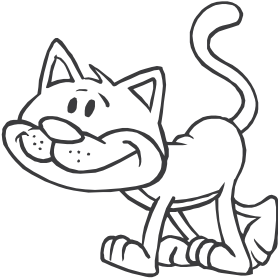

c \_ t

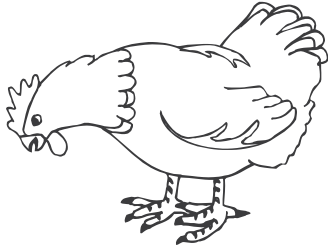

h \_ n

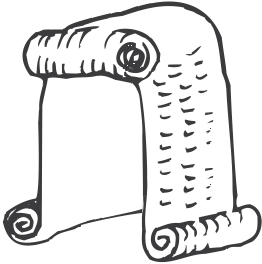

w \_ g

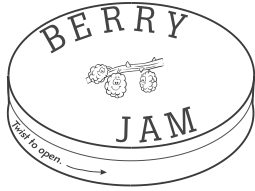

l \_ d

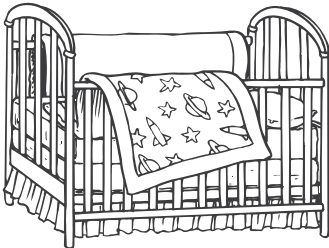

c \_ t

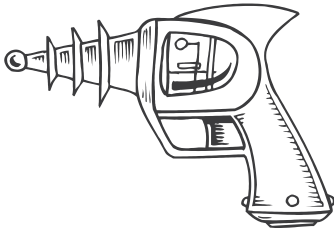

g \_ n

Name \_\_\_\_\_



Trace the sounds. Cut out the squares.  
Paste them onto the picture squares.

Middle sounds.

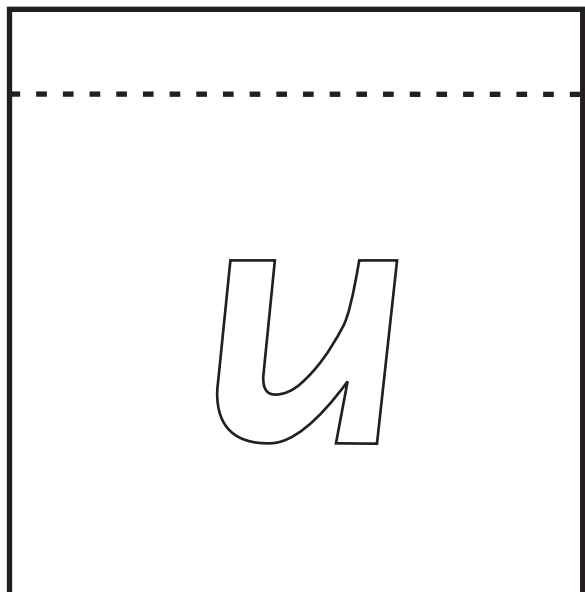
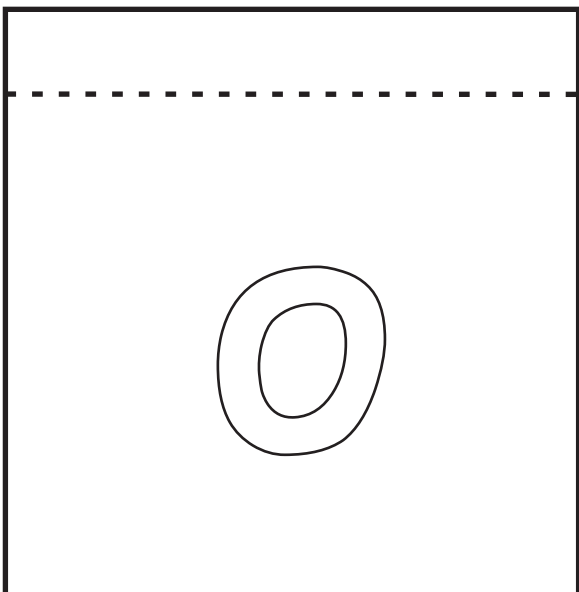
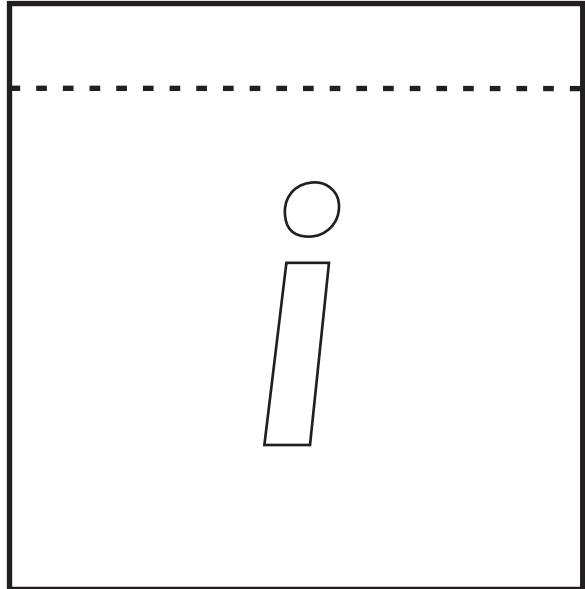
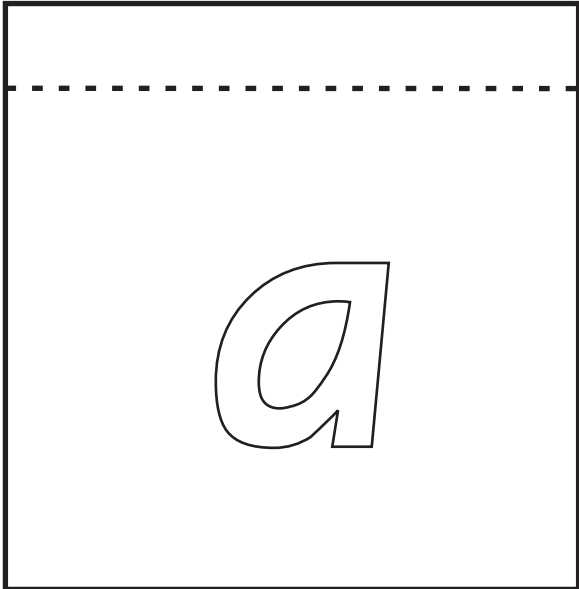
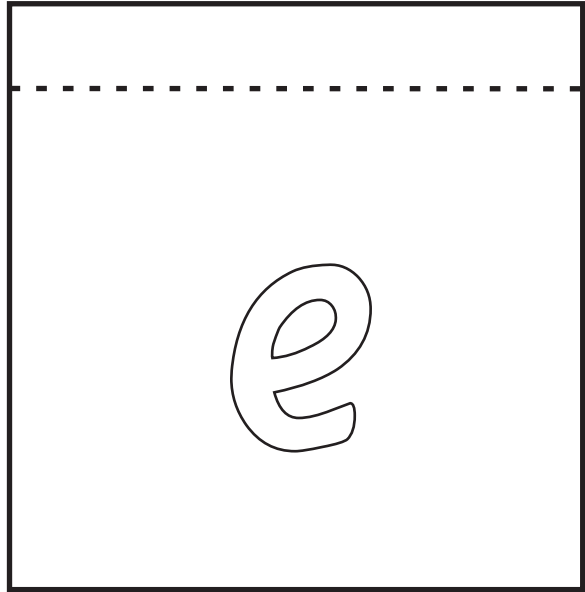
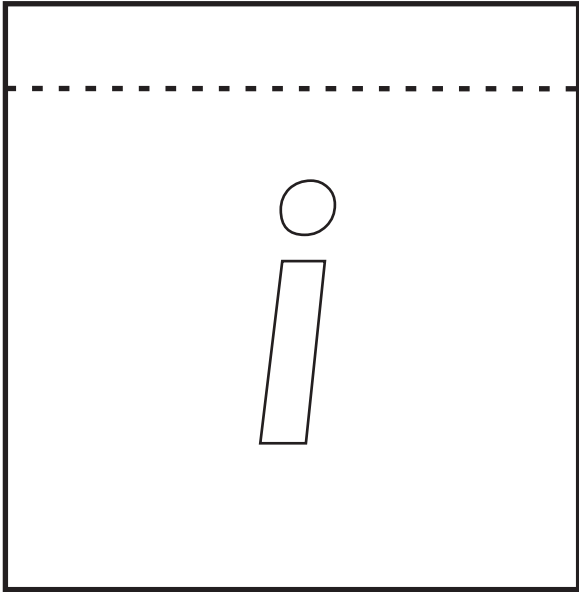



Name \_\_\_\_\_



Colour the pictures.  
Write the missing sounds.

Final sounds.

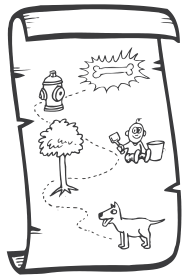

ma \_\_\_\_\_

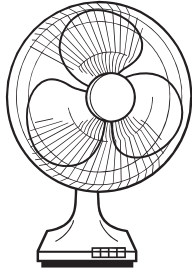

fa \_\_\_\_\_



ta \_\_\_\_\_

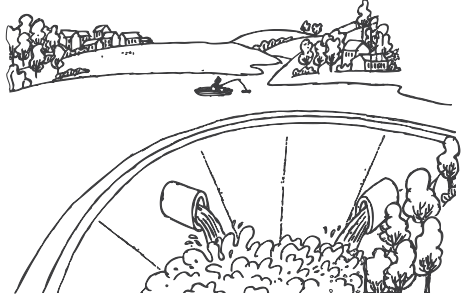

da \_\_\_\_\_

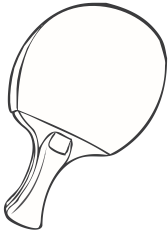

ba \_\_\_\_\_



fa \_\_\_\_\_

Name \_\_\_\_\_



Trace the sounds. Cut out the squares.  
Paste them onto the picture squares.

Final sounds.

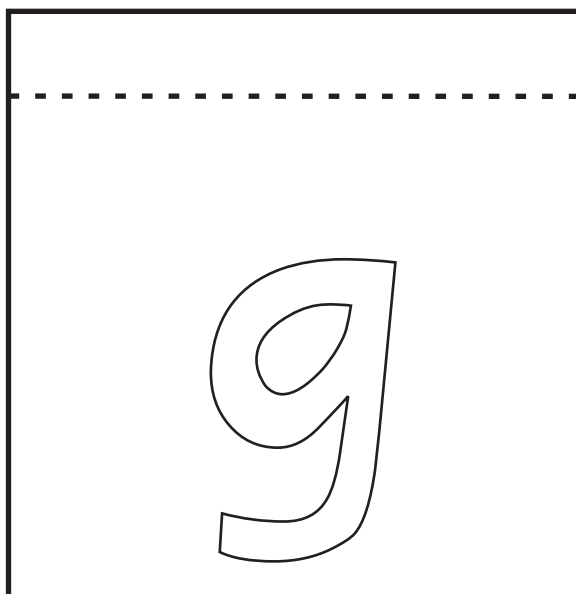
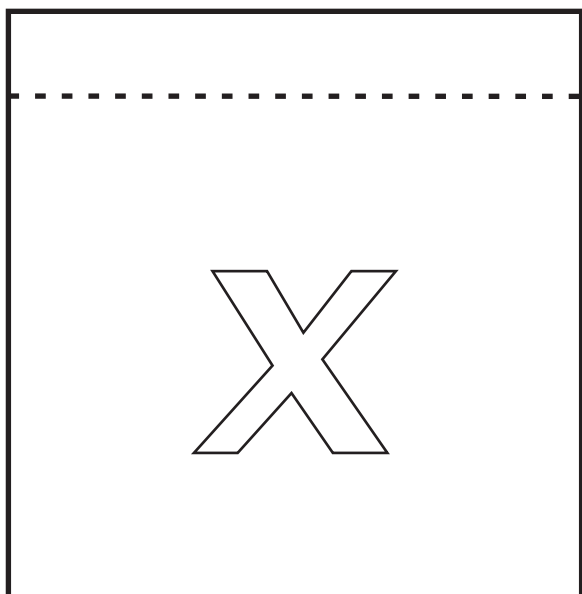
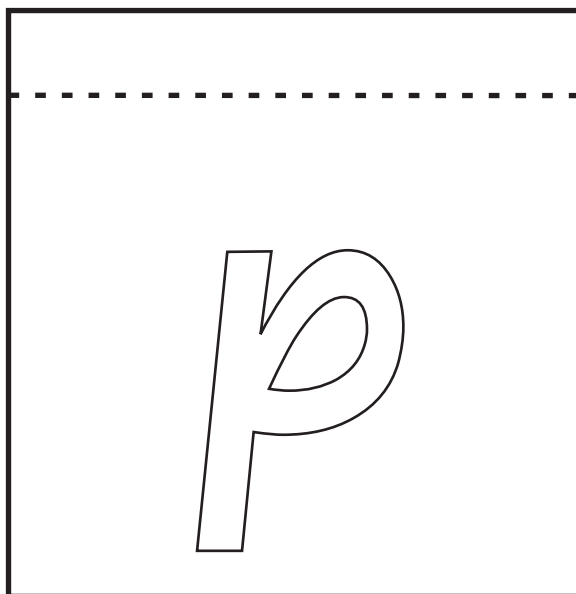
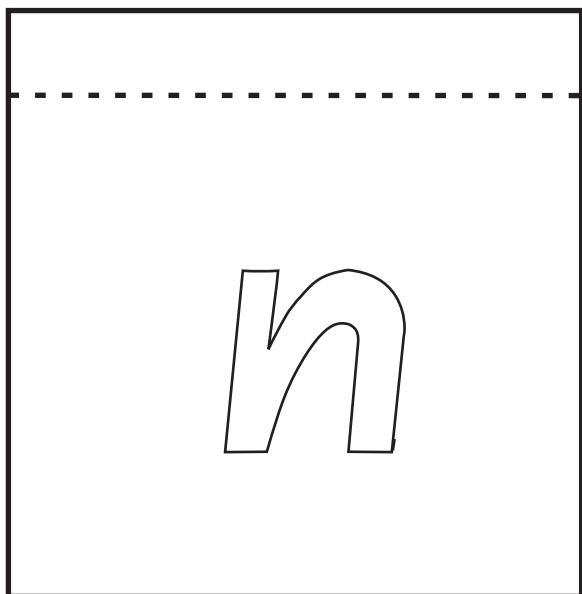
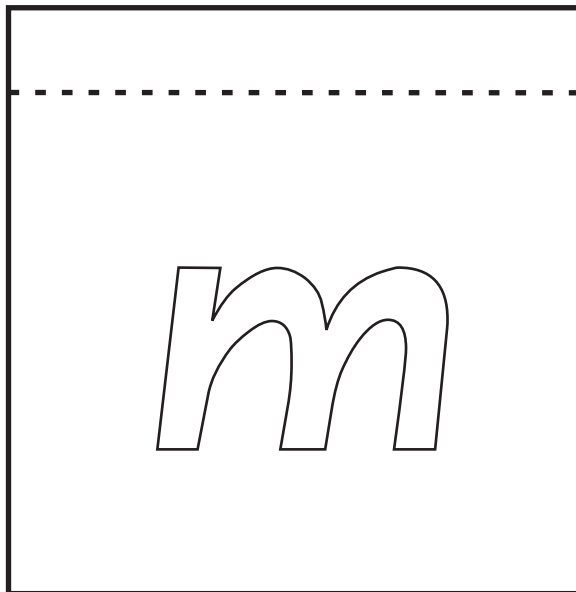
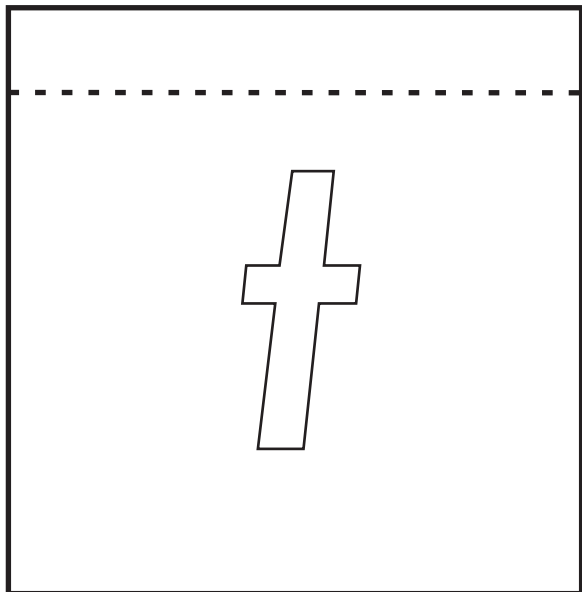

Name \_\_\_\_\_



Colour the pictures.  
Write the missing sounds.

Final sounds.

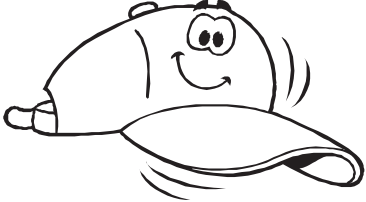

ca \_\_\_\_\_

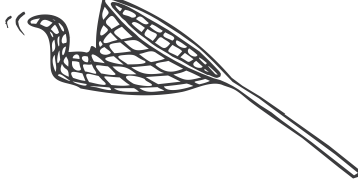

ne \_\_\_\_\_

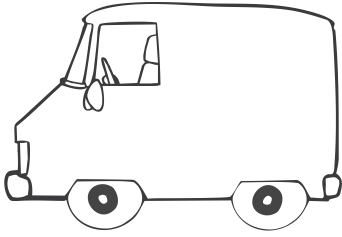

va \_\_\_\_\_



lo \_\_\_\_\_

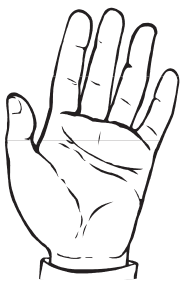

han \_\_\_\_\_

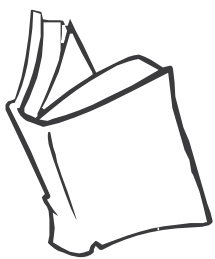

boo \_\_\_\_\_

Name \_\_\_\_\_



Trace the sounds. Cut out the squares.  
Paste them onto the picture squares.

Final sounds.

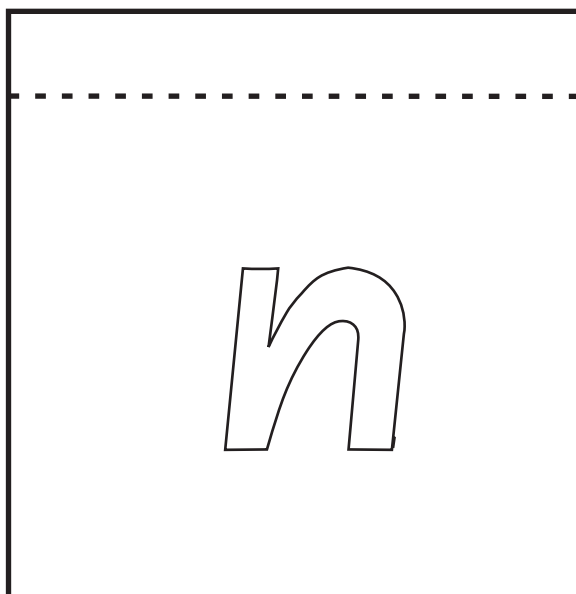
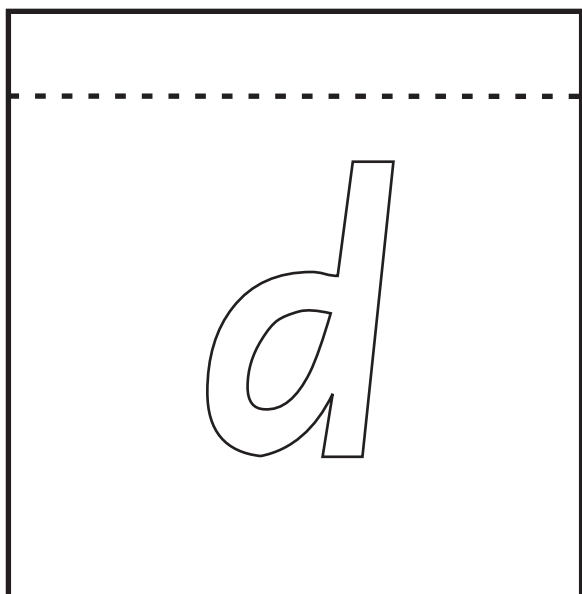
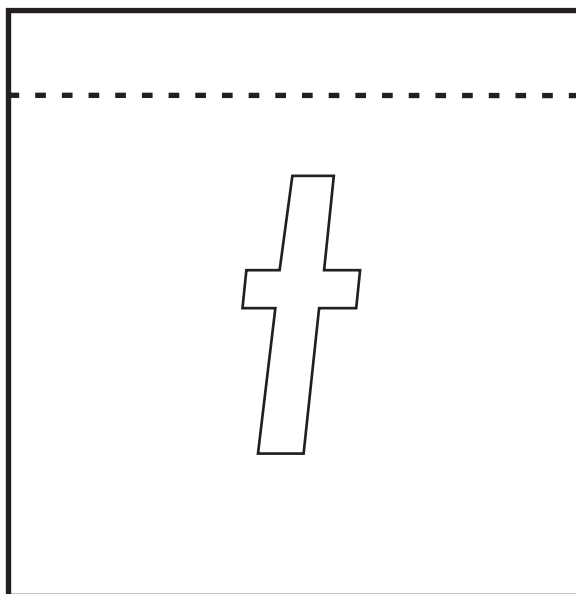
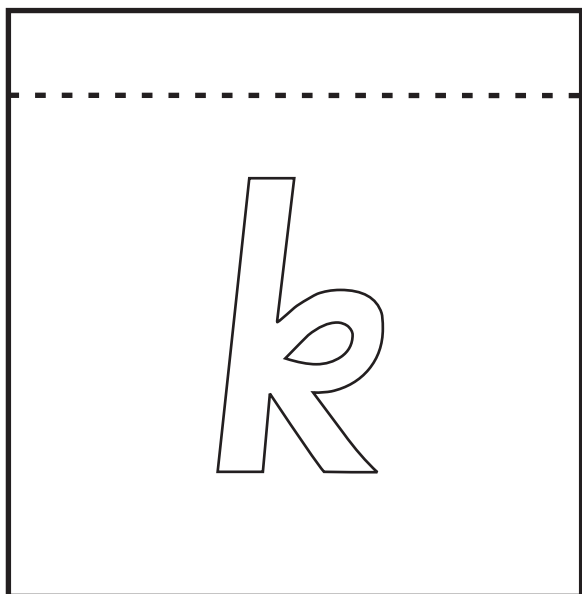
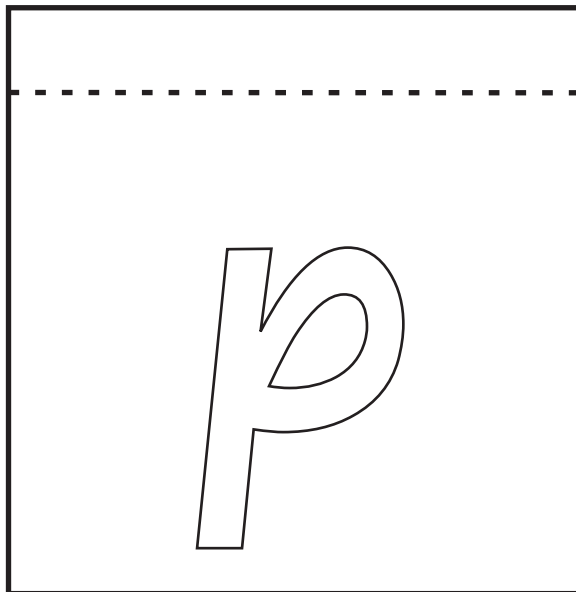
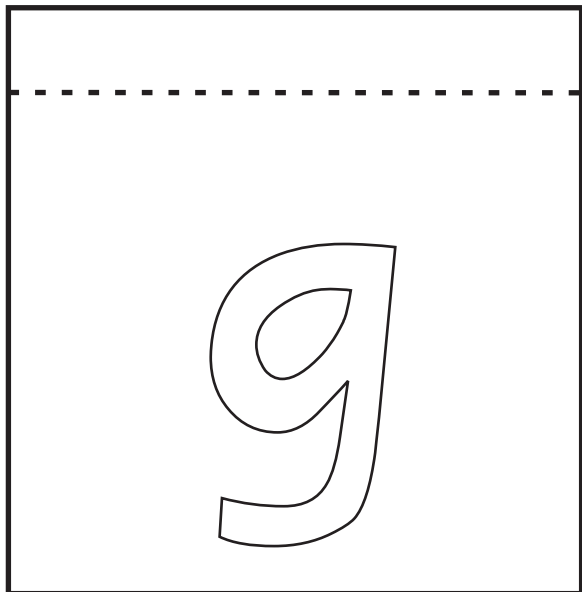

Name \_\_\_\_\_



Colour the pictures.  
Write the missing sounds.

Final sounds.



bow \_\_\_\_\_

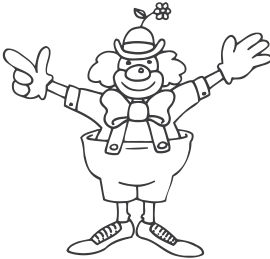

clow \_\_\_\_\_

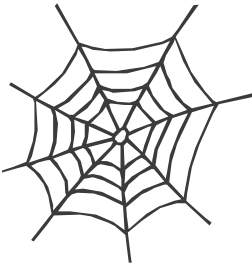

we \_\_\_\_\_

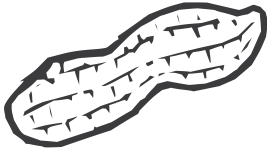

nu \_\_\_\_\_



si \_\_\_\_\_



mu \_\_\_\_\_

Name \_\_\_\_\_



Trace the sounds. Cut out the squares.  
Paste them onto the picture squares.

Final sounds.

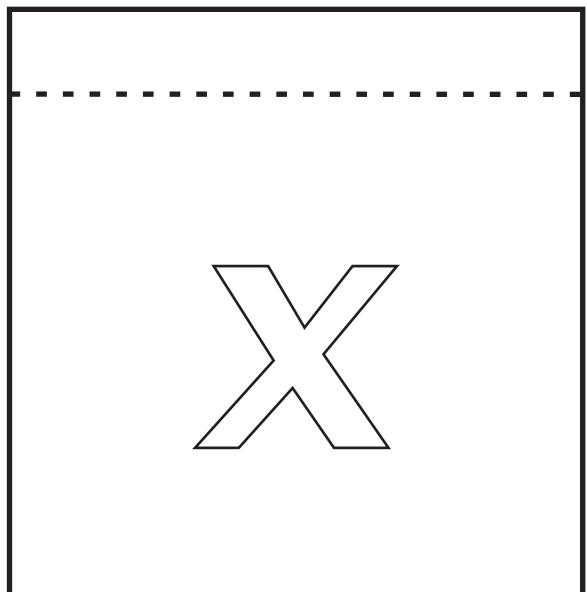
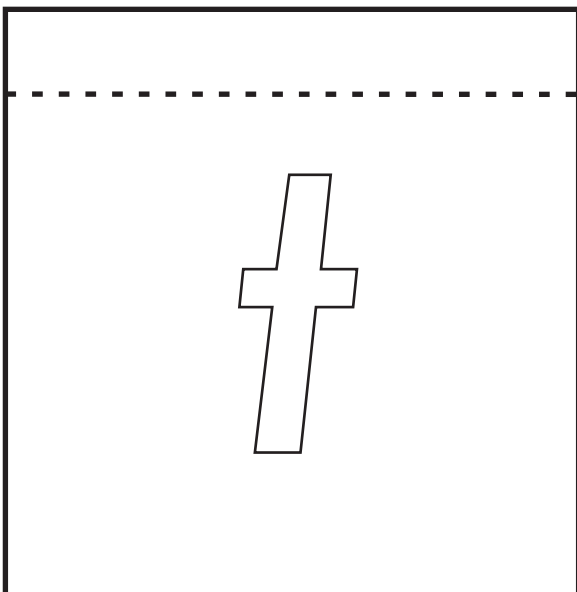
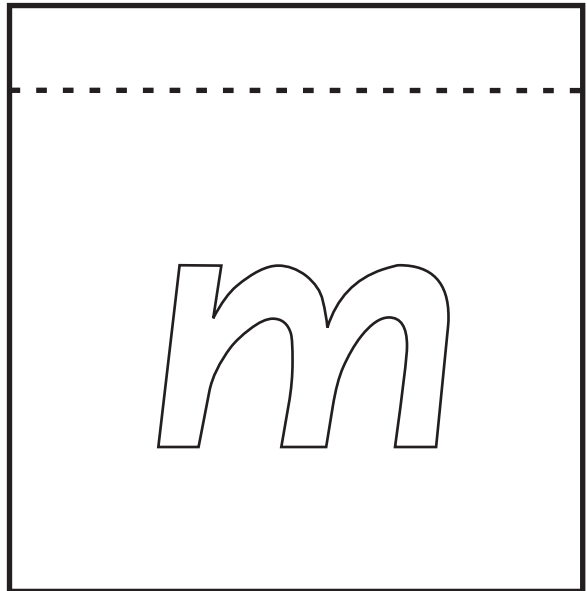
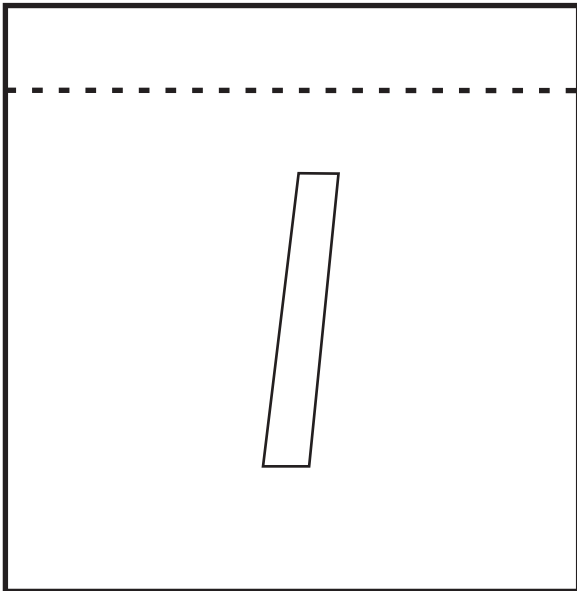
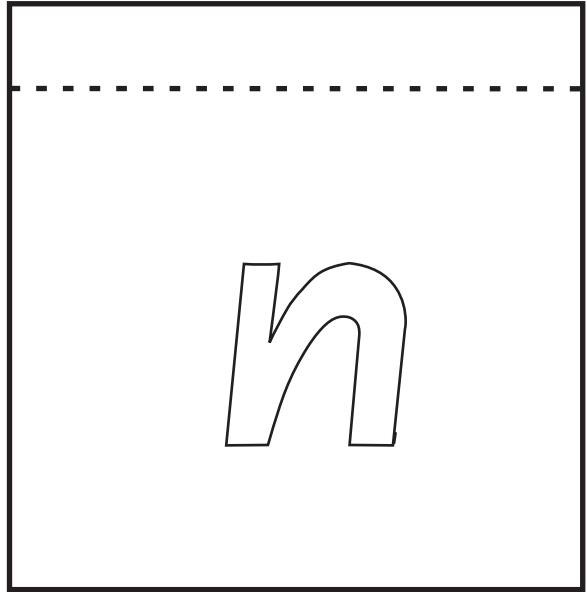
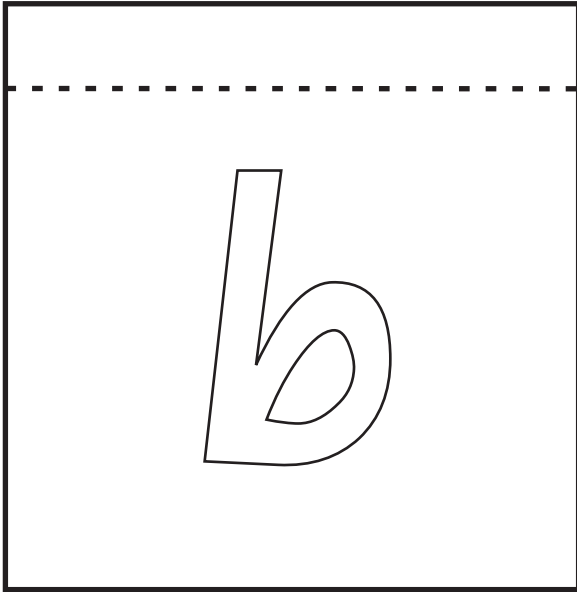

Name \_\_\_\_\_



Colour the pictures.  
Write the missing sounds.

Final sounds.

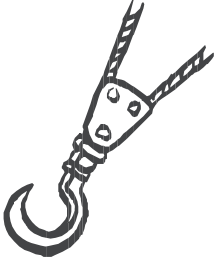

hoo \_\_\_\_\_

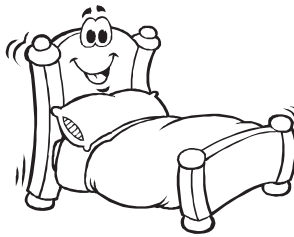

be \_\_\_\_\_



ar \_\_\_\_\_

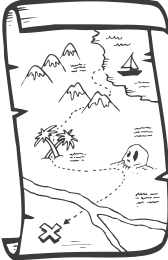

ma \_\_\_\_\_



lea \_\_\_\_\_

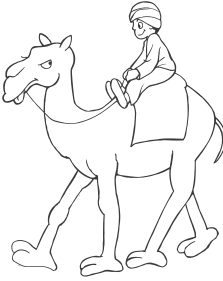

came \_\_\_\_\_

Name \_\_\_\_\_



Trace the sounds. Cut out the squares.  
Paste them onto the picture squares.

Final sounds.

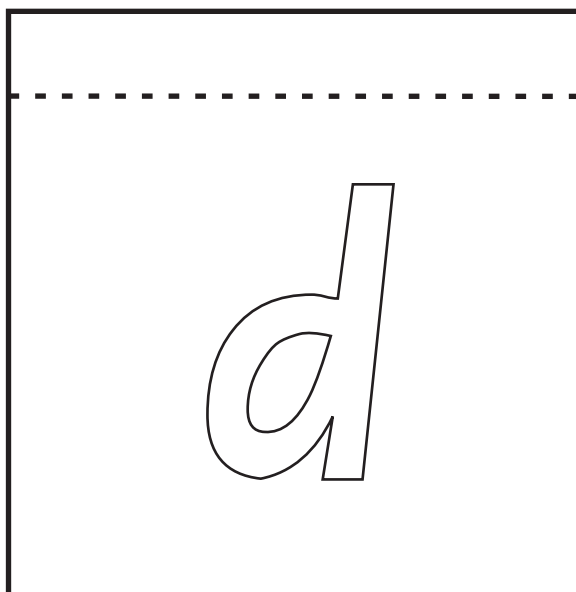
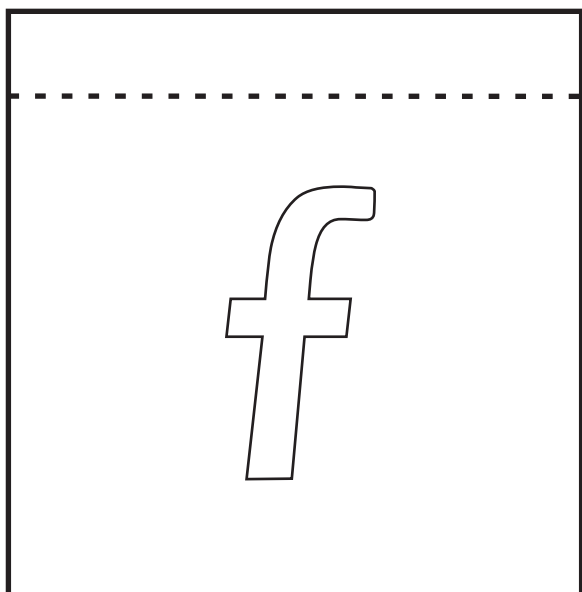
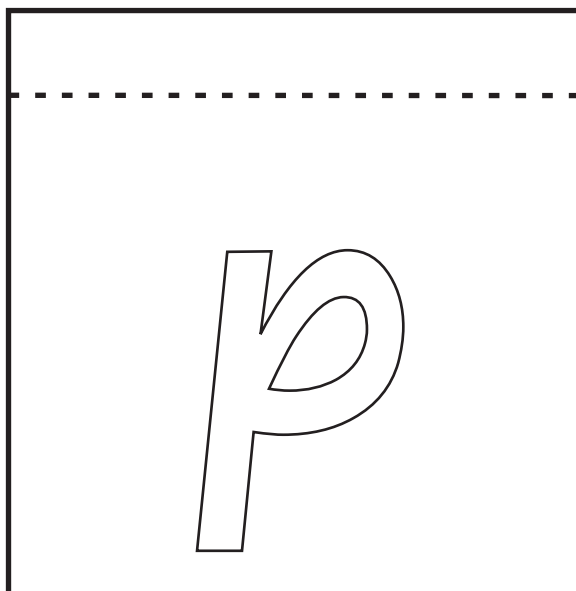
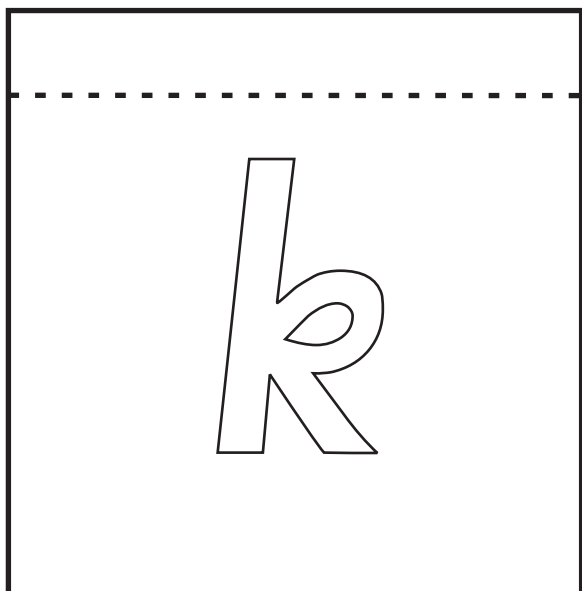
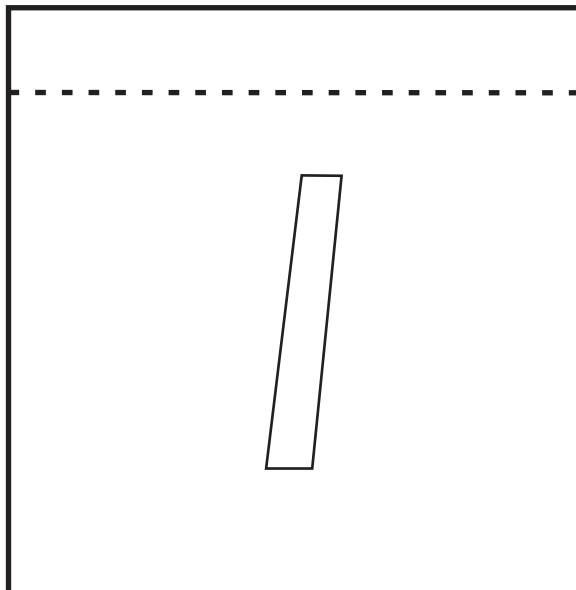
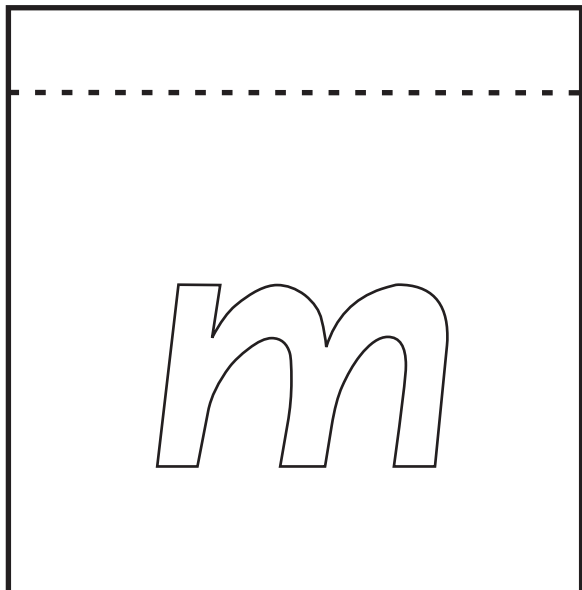



Name \_\_\_\_\_



Colour the pictures.  
Write the missing sounds.

Final sounds.

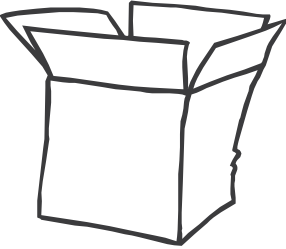

bo \_\_\_\_\_

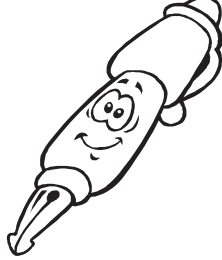

pe \_\_\_\_\_



bu \_\_\_\_\_

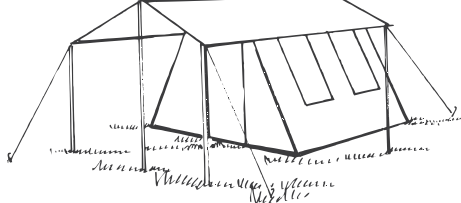

ten \_\_\_\_\_



fro \_\_\_\_\_



cra \_\_\_\_\_

Name \_\_\_\_\_



Trace the sounds. Cut out the squares.  
Paste them onto the picture squares.

Final sounds.

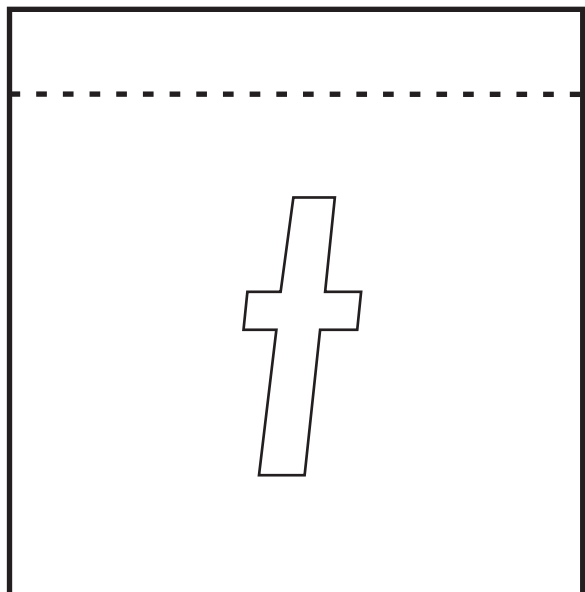
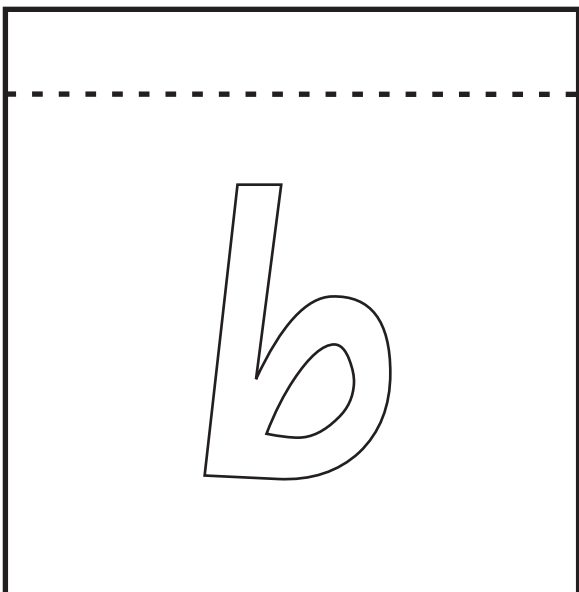
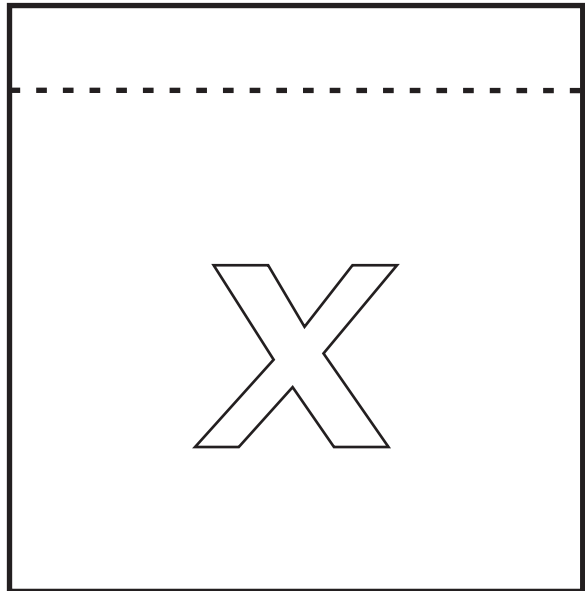
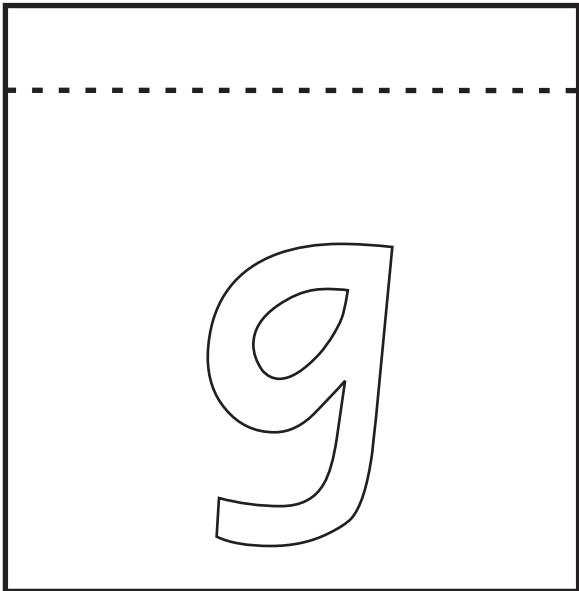
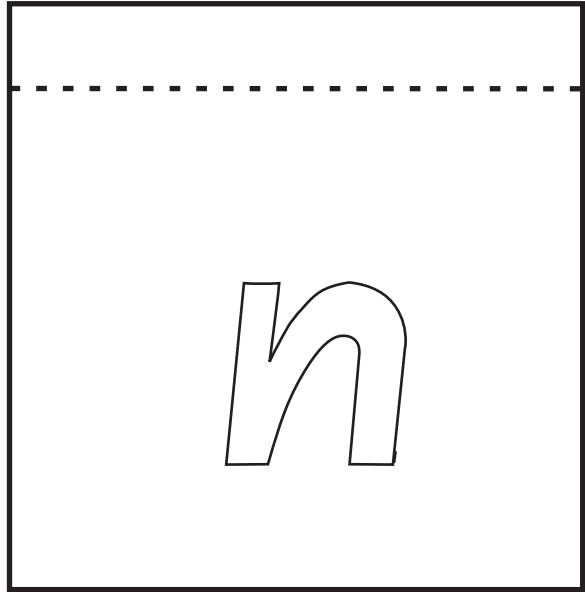
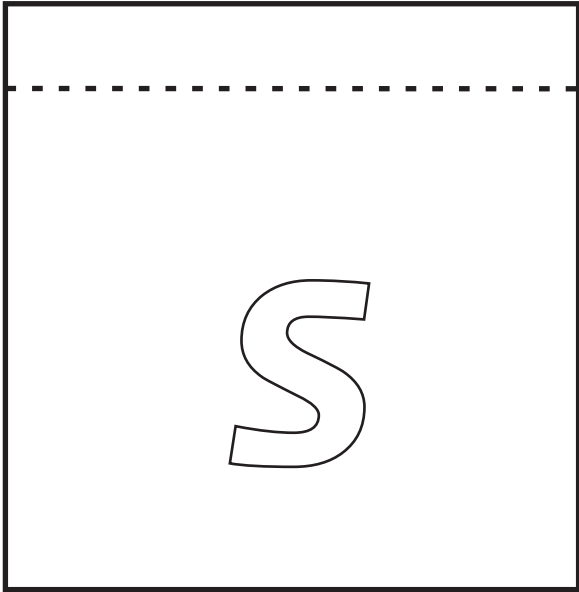

Name \_\_\_\_\_



Colour the pictures.  
Write the missing sounds.

Final sounds.

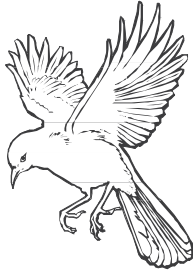

bir\_\_

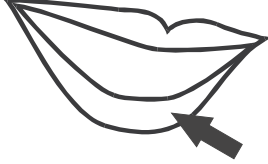

li\_\_



gir\_\_



tu\_\_

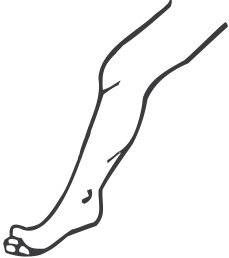

le\_\_

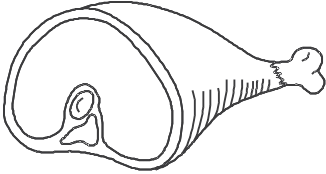

ha\_\_

Name \_\_\_\_\_



Trace the sounds. Cut out the squares.  
Paste them onto the picture squares.

Final sounds.

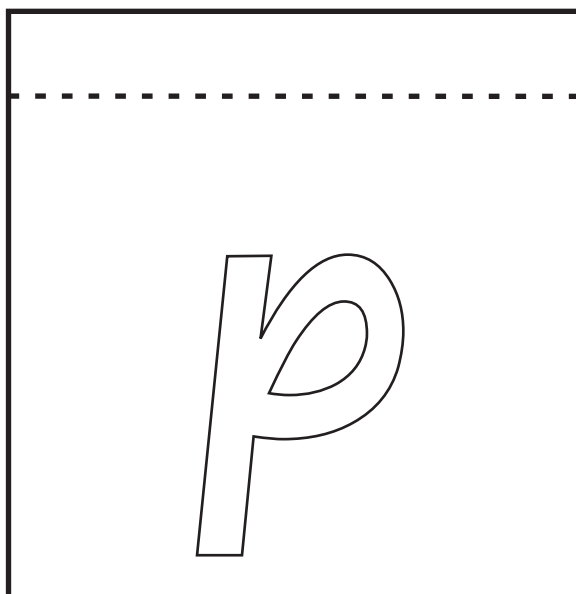
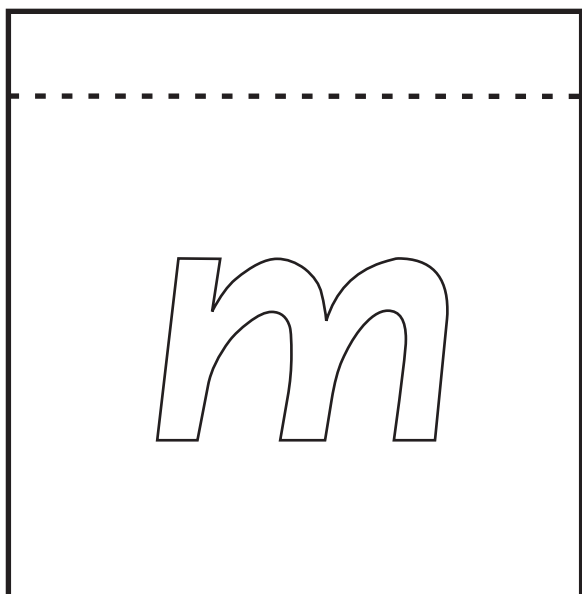
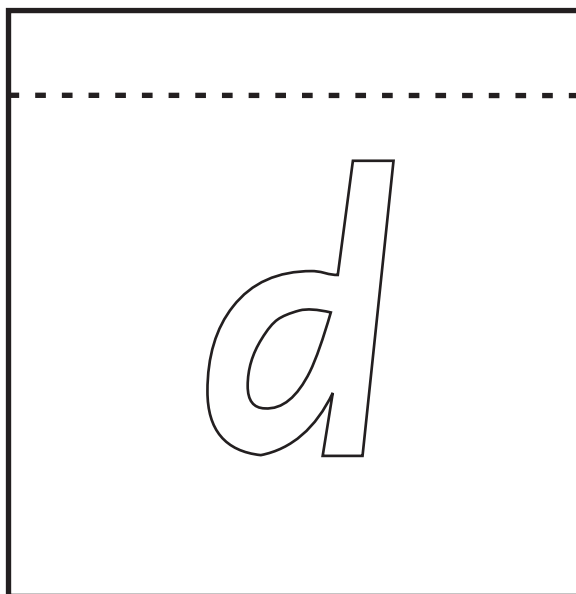
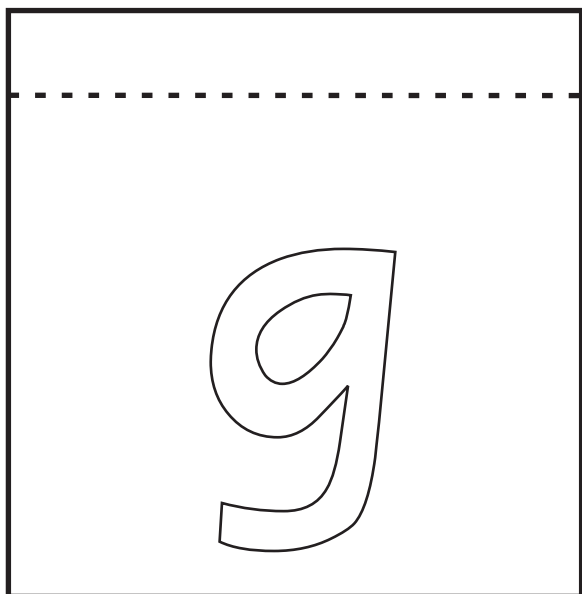
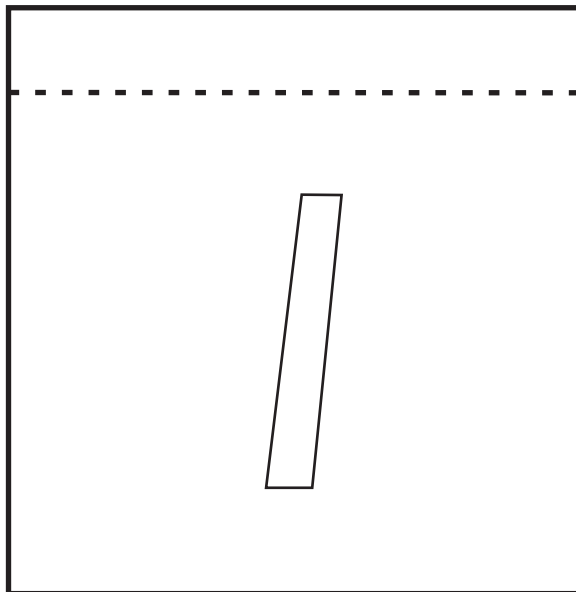
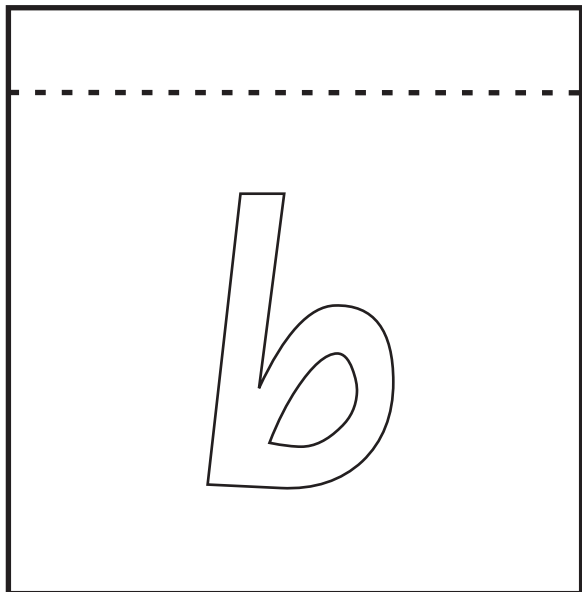

Name \_\_\_\_\_



Colour the pictures.  
Write the missing sounds.

Beginning, Middle, Final

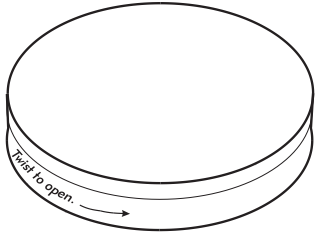

A line drawing of a circular lid with a small arrow and the text "Lid to open." on its side.

li \_\_\_\_\_



A line drawing of a young girl with a large arrow pointing to her chest. She is wearing a shirt that says "I'M A GOOD GIRL".

bi \_\_\_\_\_

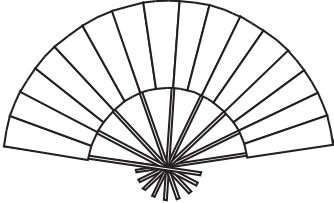

A line drawing of an open folding fan.

\_\_\_\_\_an



A line drawing of a crumpled map with the word "MAP" written on it.

m \_\_\_\_\_p



A line drawing of a mouse facing left.

\_\_\_\_\_ouse



A line drawing of a cartoon rat with a large nose, wearing a shirt and pants, running.

r \_\_\_\_\_n

Name \_\_\_\_\_

Trace the sounds. Cut out the squares.  
Paste them onto the picture squares.



Beginning, Middle, Final

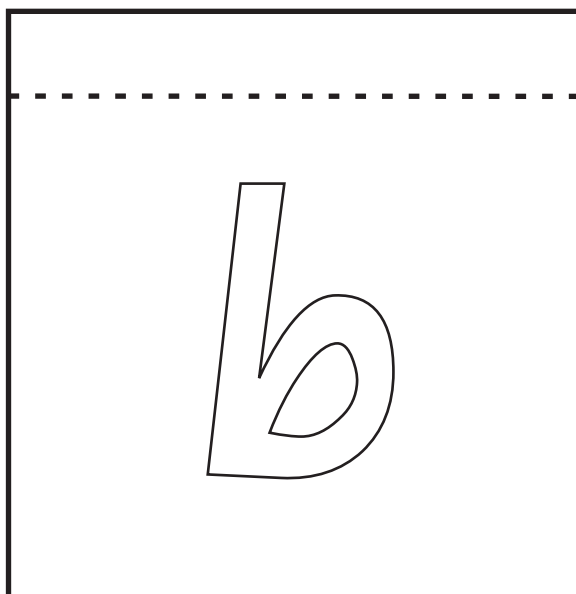
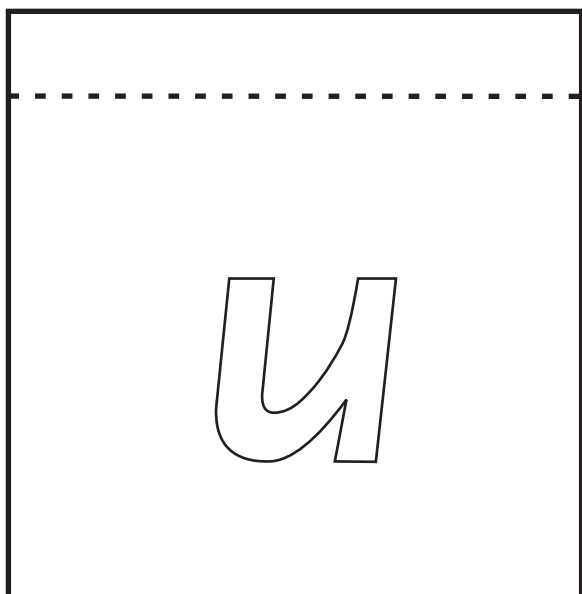
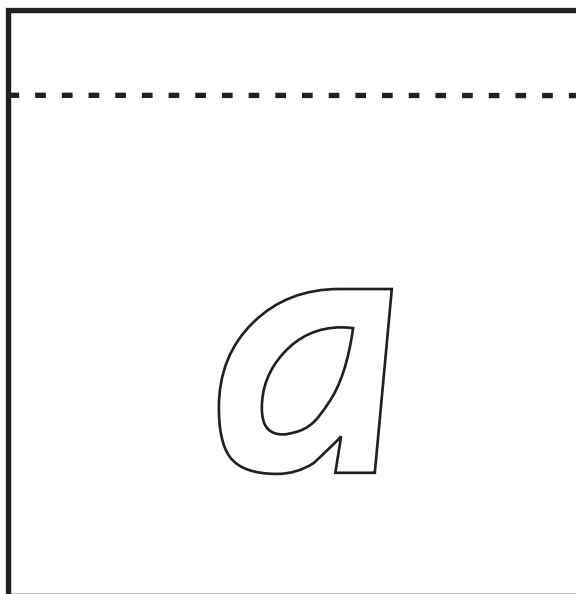
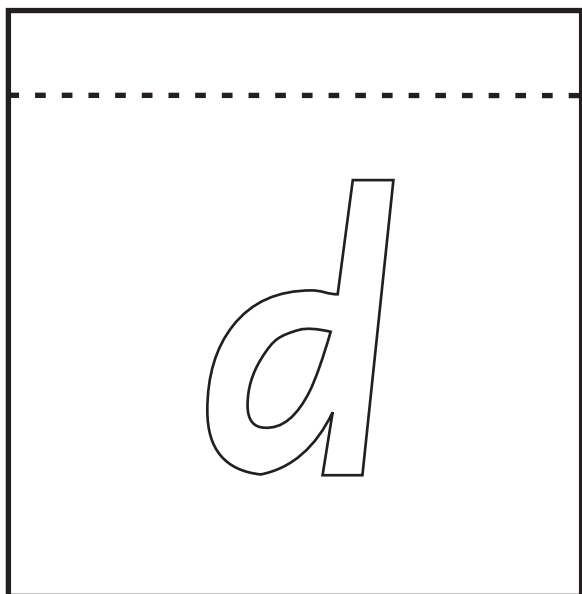
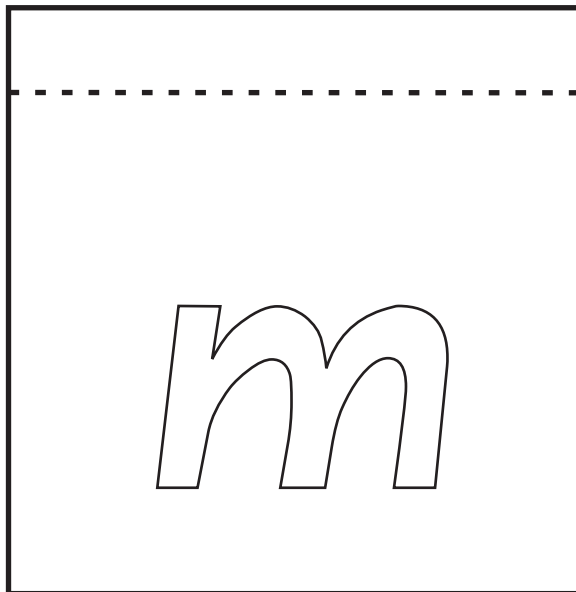
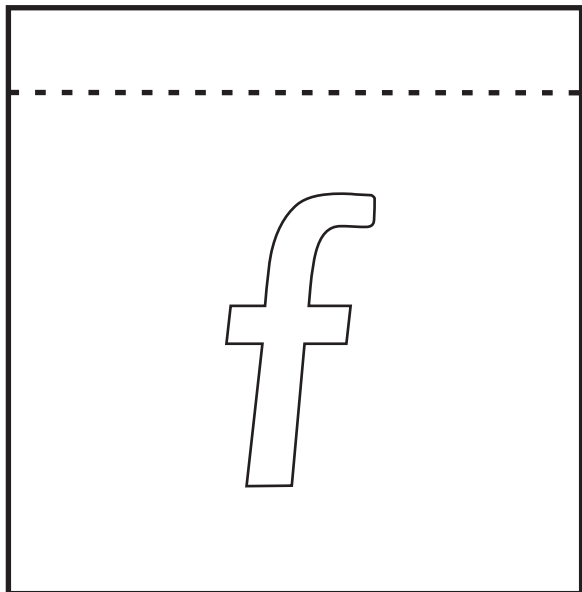

Name \_\_\_\_\_



Colour the pictures.  
Write the missing sounds.

Beginning, Middle, Final

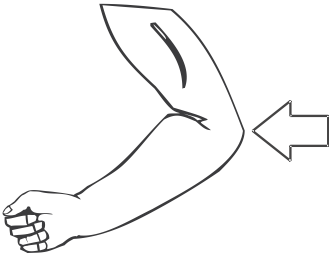

\_\_\_\_\_lbow



dru\_\_\_\_\_



t\_\_\_\_\_p

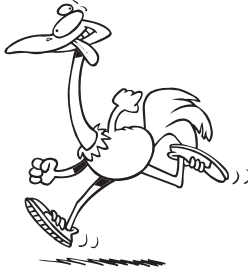

\_\_\_\_\_strich

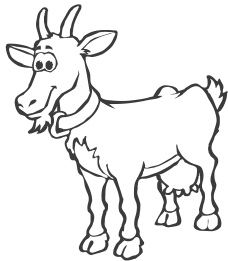

goa\_\_\_\_\_



\_\_\_\_\_ig

Name \_\_\_\_\_

Trace the sounds. Cut out the squares.  
Paste them onto the picture squares.



Beginning, Middle, Final

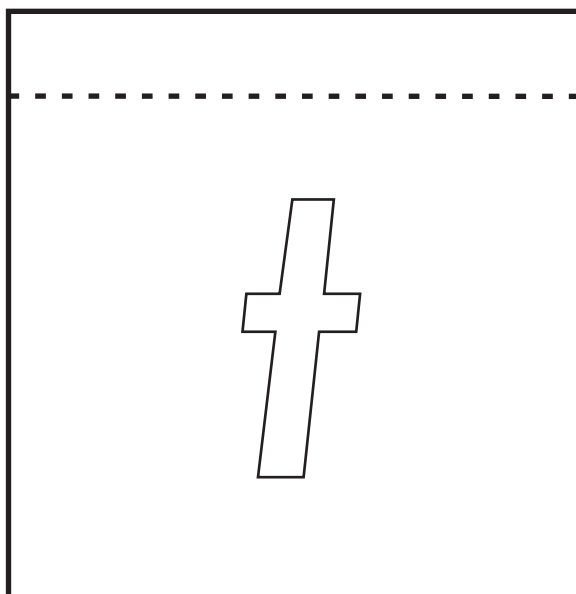
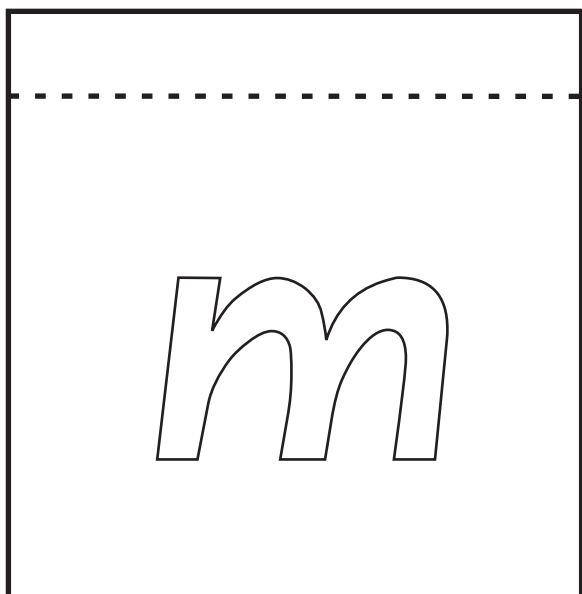
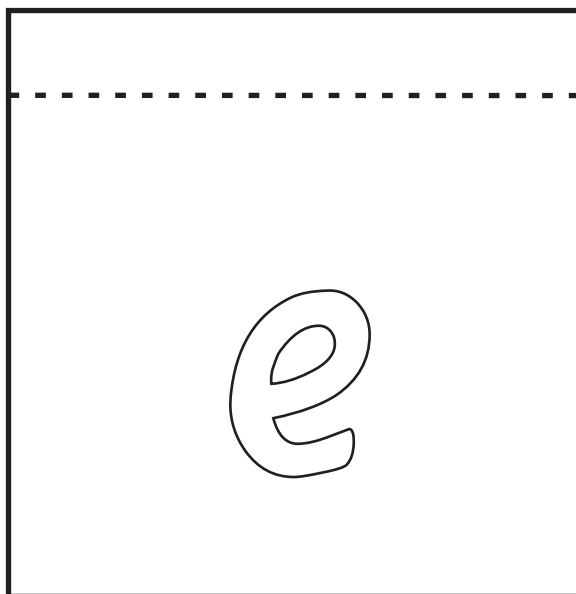
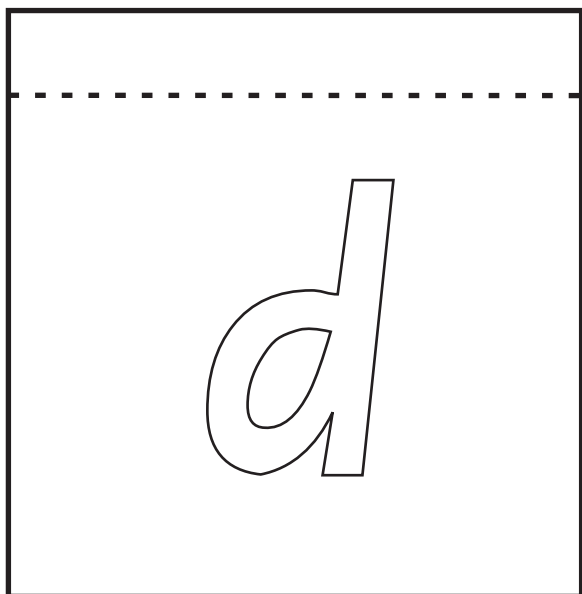
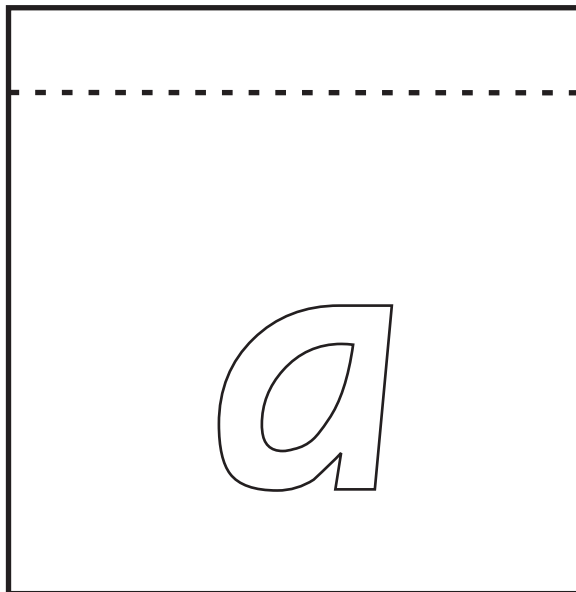
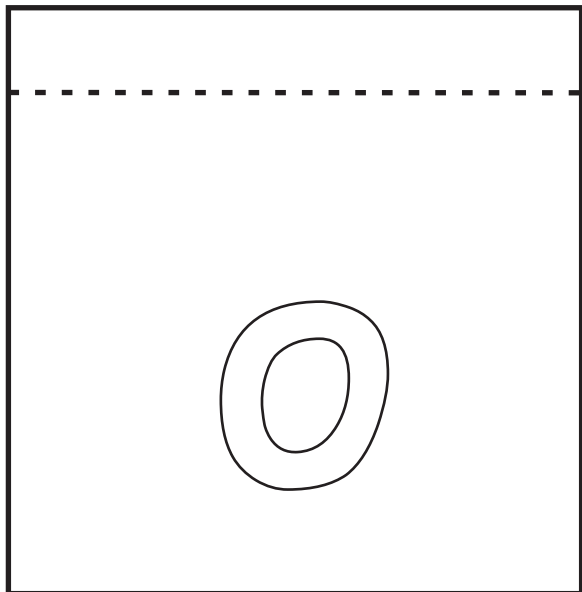



Name \_\_\_\_\_



Beginning, Middle, Final

Colour the pictures.  
Write the missing sounds.



nk



d\_g



l\_g



ho\_

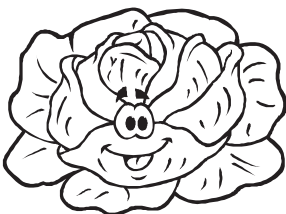

\_ettuce



\_igsaw

Name \_\_\_\_\_



Trace the sounds. Cut out the squares.  
Paste them onto the picture squares.

Beginning, Middle, Final

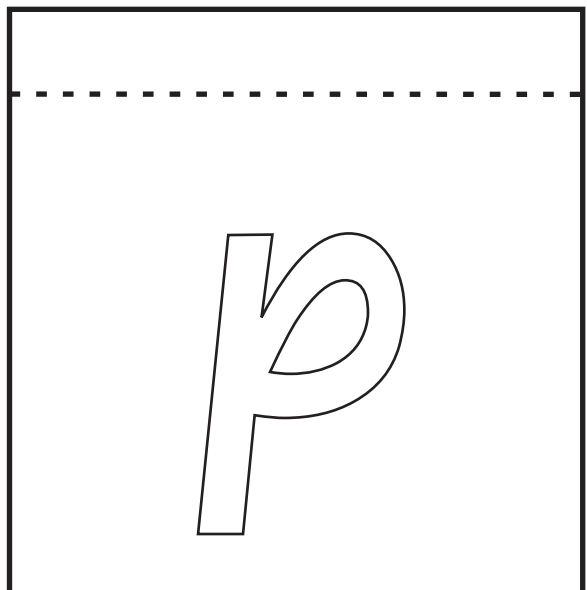
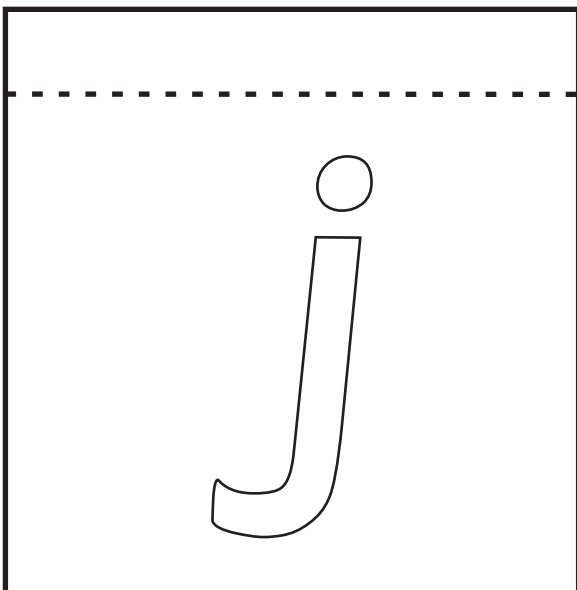
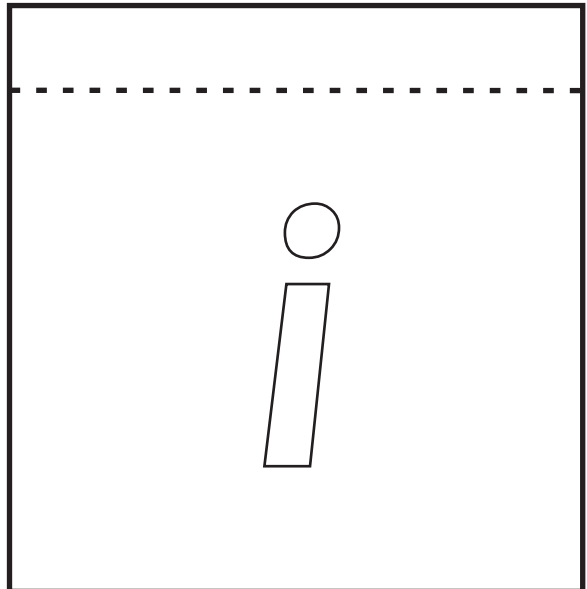
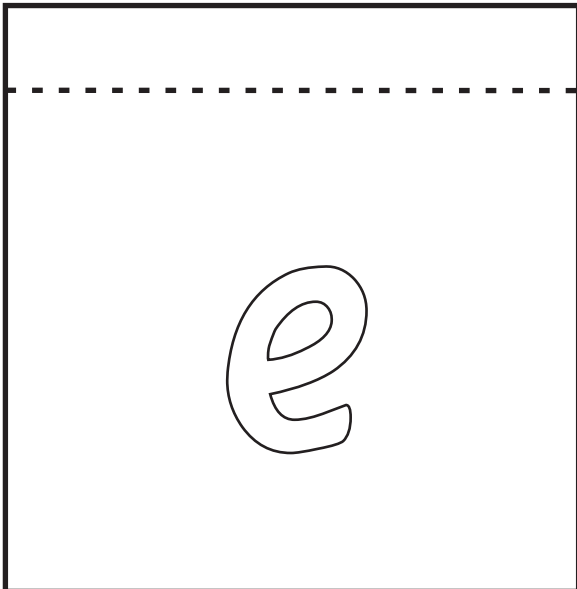
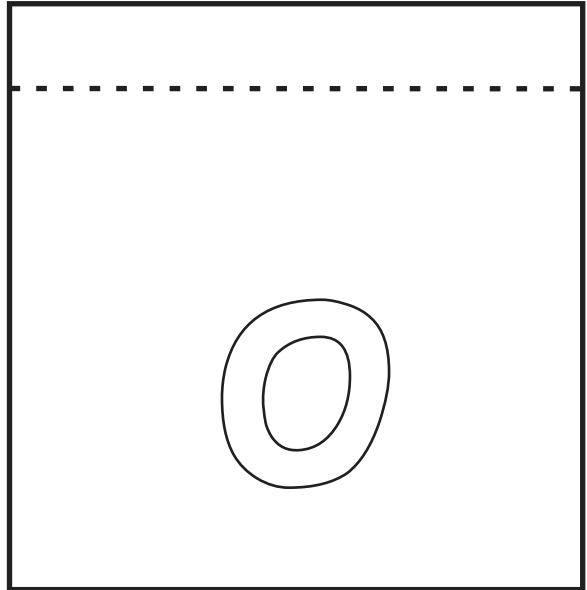
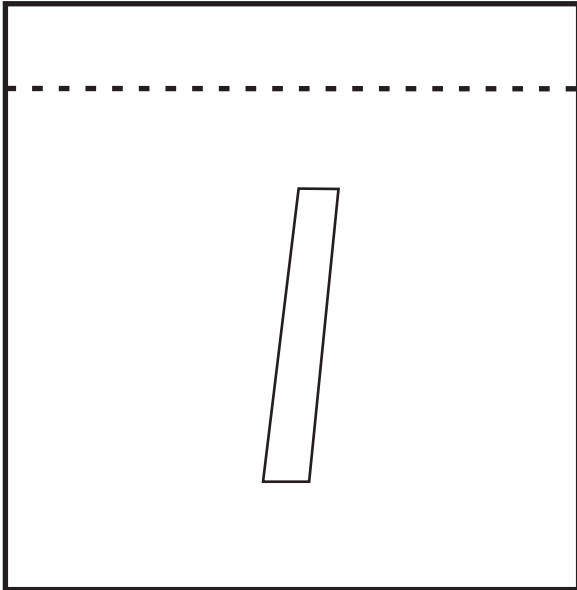

Name \_\_\_\_\_



Colour the pictures.  
Write the missing sounds.

Beginning, Middle, Final



\_\_\_\_\_encil

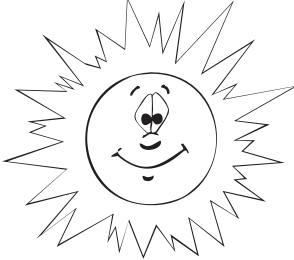

s\_\_\_\_n

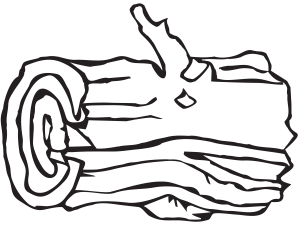

l\_\_\_\_g



\_\_\_\_ave



\_\_\_\_rrow



ma\_\_\_\_\_

Name \_\_\_\_\_

Trace the sounds. Cut out the squares.  
Paste them onto the picture squares.



Beginning, Middle, Final

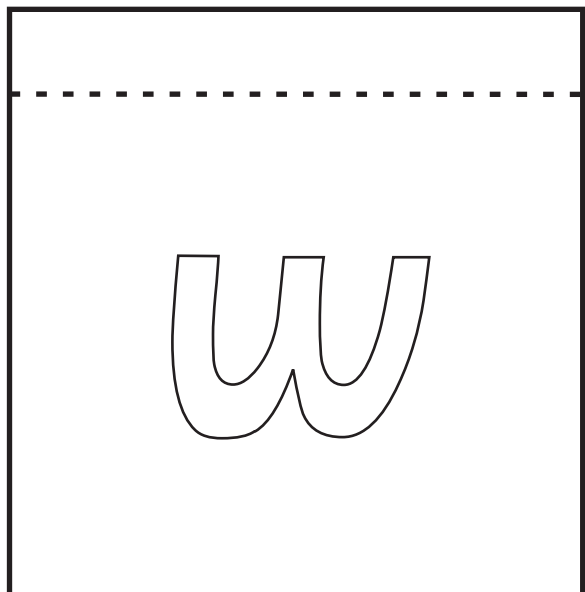
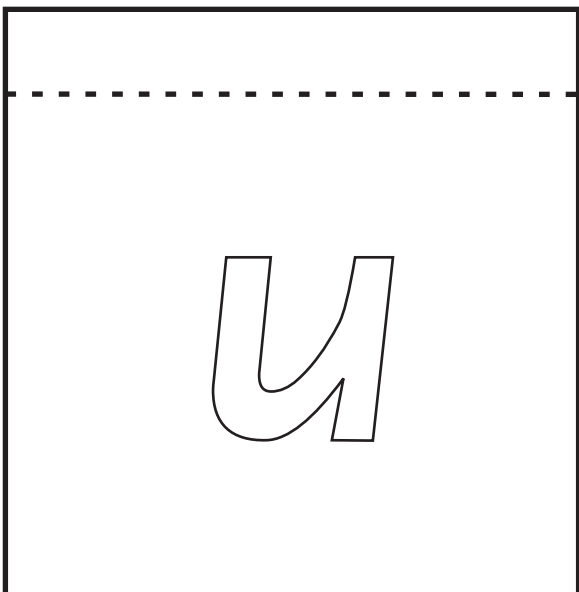
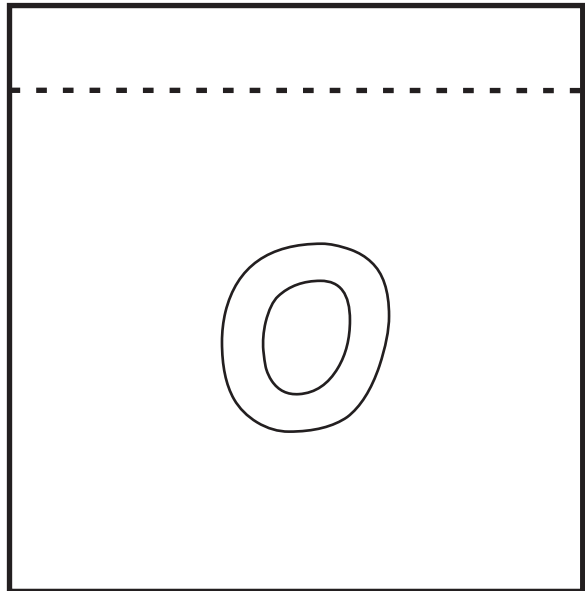
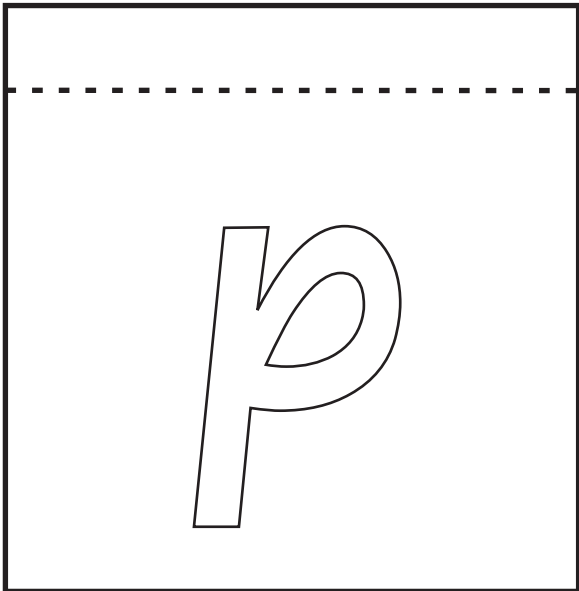
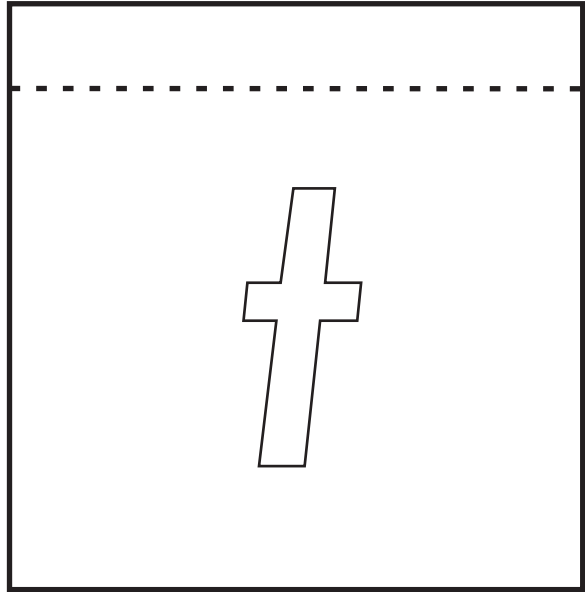
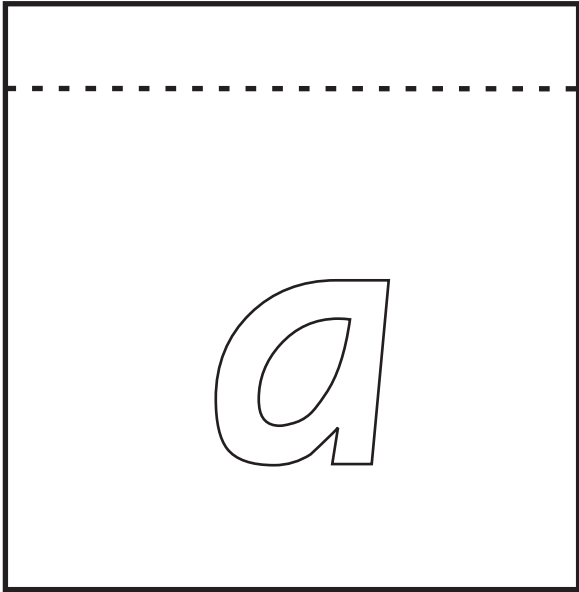

Name \_\_\_\_\_



Colour the pictures.  
Write the missing sounds.

Beginning, Middle, Final



\_\_onkey

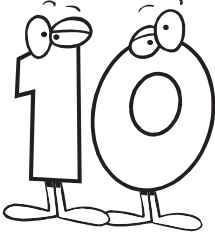

t\_\_n



do\_\_

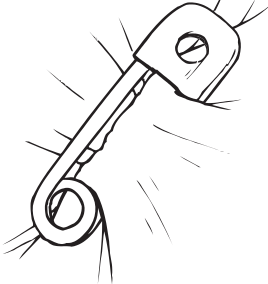

p\_\_n

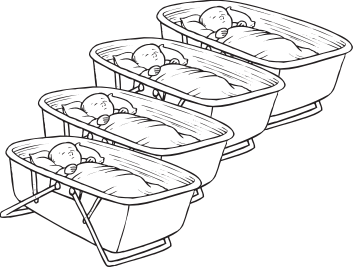

\_\_uads



for\_\_

Name \_\_\_\_\_

Trace the sounds. Cut out the squares.  
Paste them onto the picture squares.



Beginning, Middle, Final

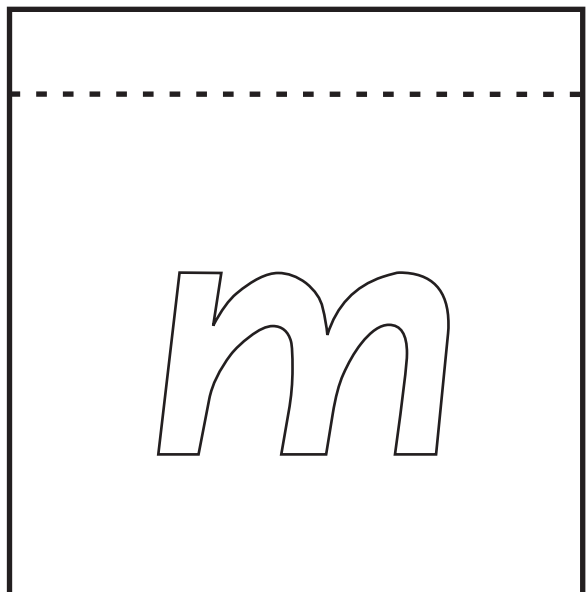
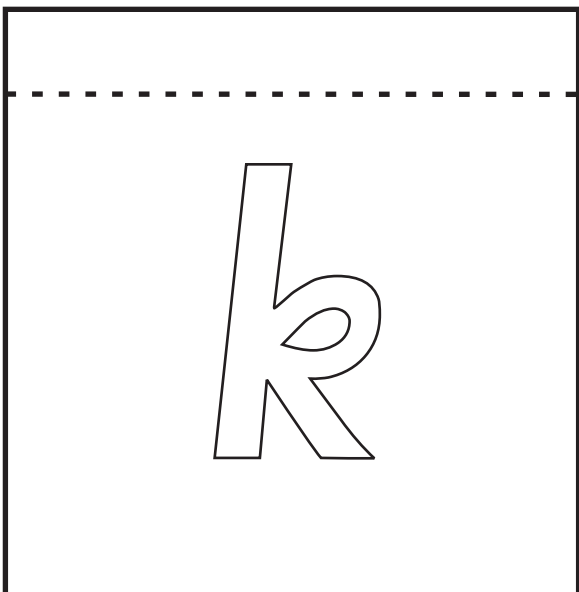
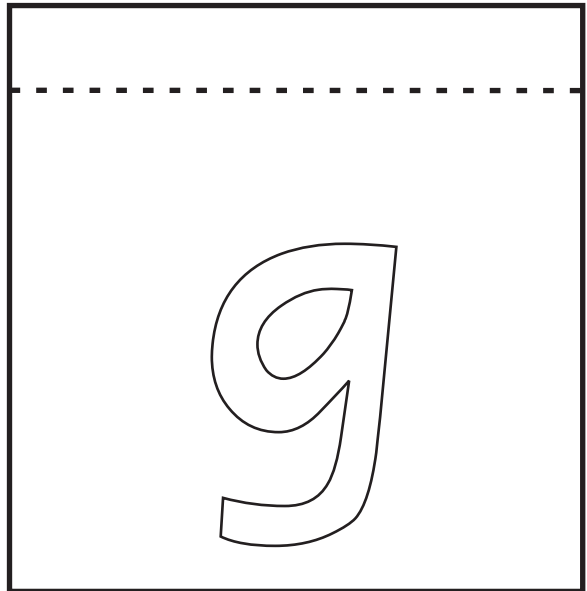
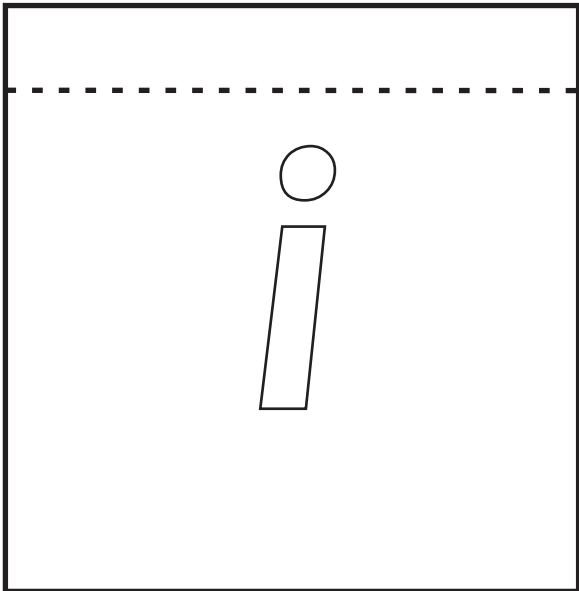
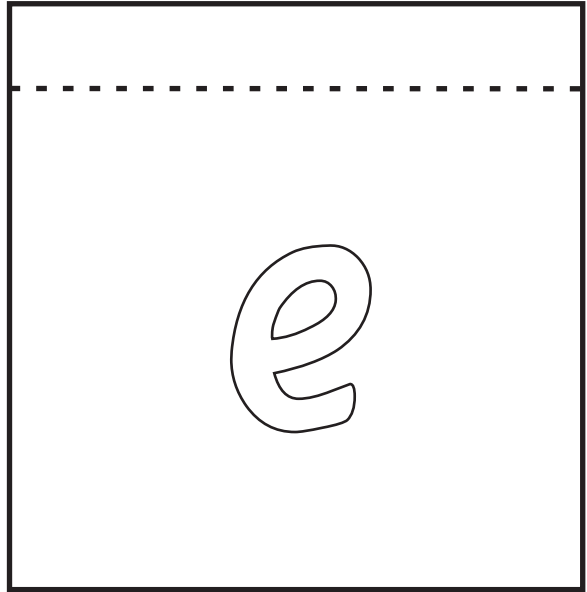
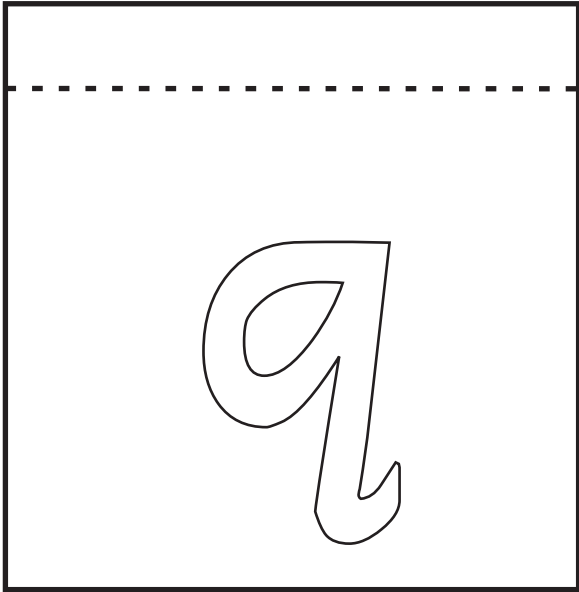

Name \_\_\_\_\_



Colour the pictures.  
Write the missing sounds.

Beginning, Middle, Final

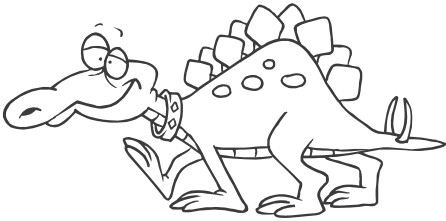

\_\_\_\_\_inosaur



t\_\_\_\_g

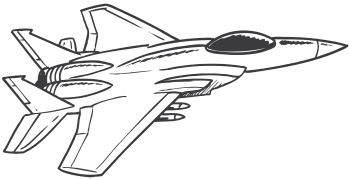

je\_\_\_\_\_

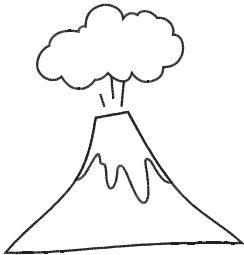

\_\_\_\_\_olcano



p\_\_\_\_p



fi\_\_\_\_\_

Name \_\_\_\_\_

Trace the sounds. Cut out the squares.  
Paste them onto the picture squares.



Beginning, Middle, Final

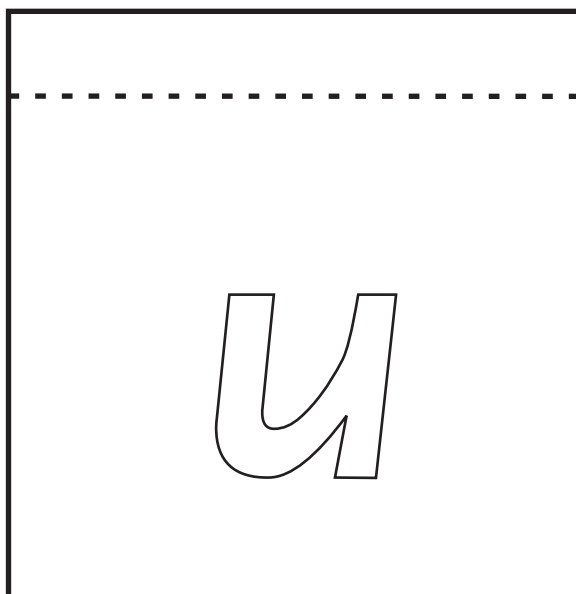
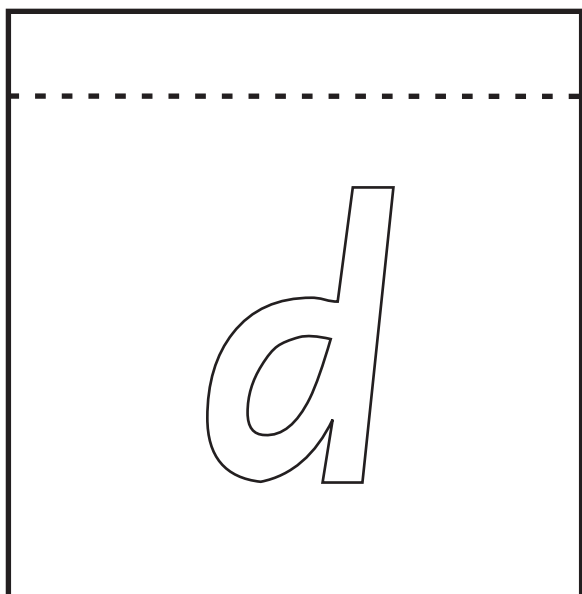
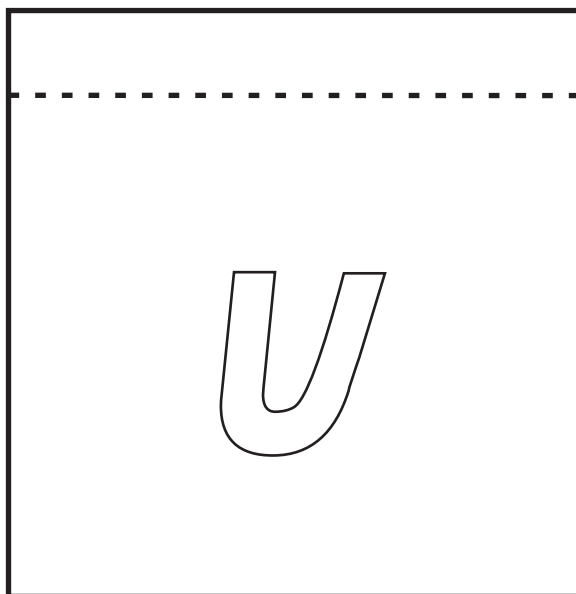
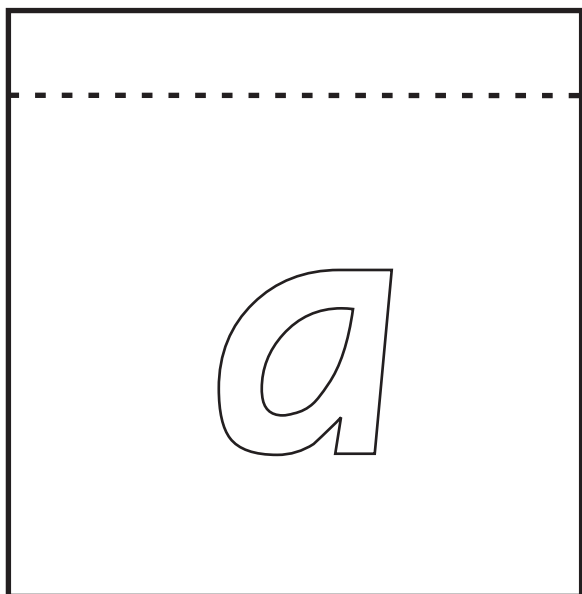
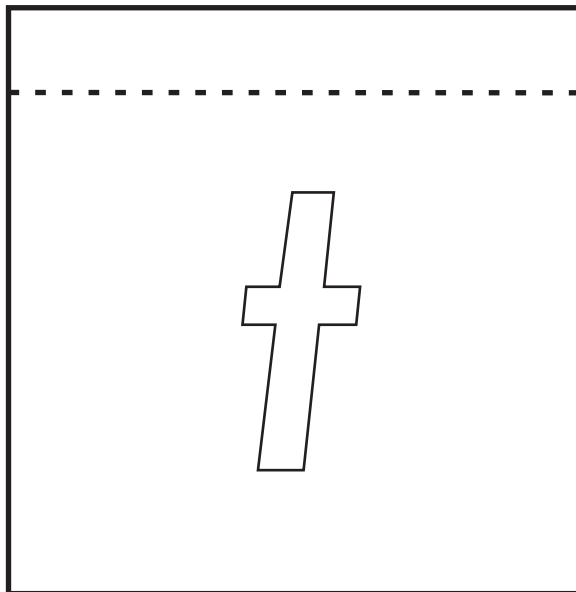
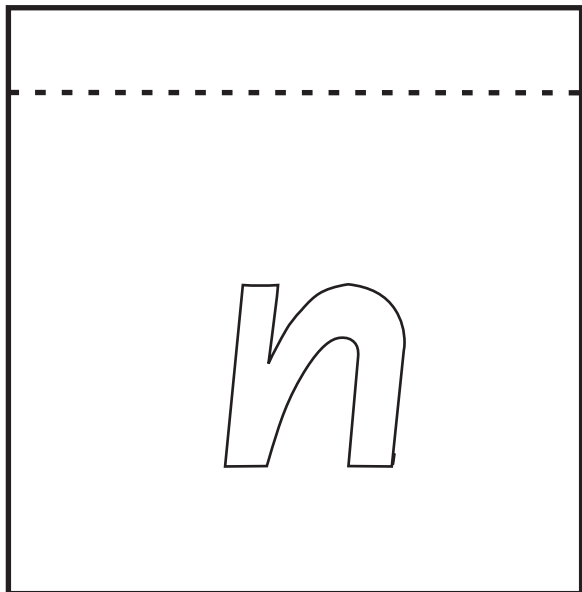



Name \_\_\_\_\_



Colour the pictures.  
Write the missing sounds.

Beginning, Middle, Final

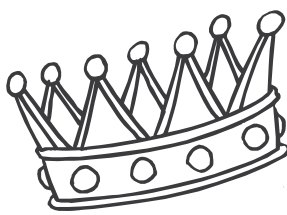

r \_ t

A cartoon rabbit with a long nose, wearing glasses, and holding a carrot. The word 'rabbit' is partially written as 'r \_ t'.

crow \_

A simple line drawing of a crown with several points and a band.

\_ ollypop

A round lollipop with a smiling face and a stick.

b \_ b

A girl's face with a bib that says 'I'M A GOOD GIRL'. An arrow points to the letter 'b' on the bib.

ba \_

A rectangular briefcase with a handle and a latch.

\_ up

A smiling cup with a face and a handle.

Name \_\_\_\_\_

Trace the sounds. Cut out the squares.  
Paste them onto the picture squares.



Beginning, Middle, Final

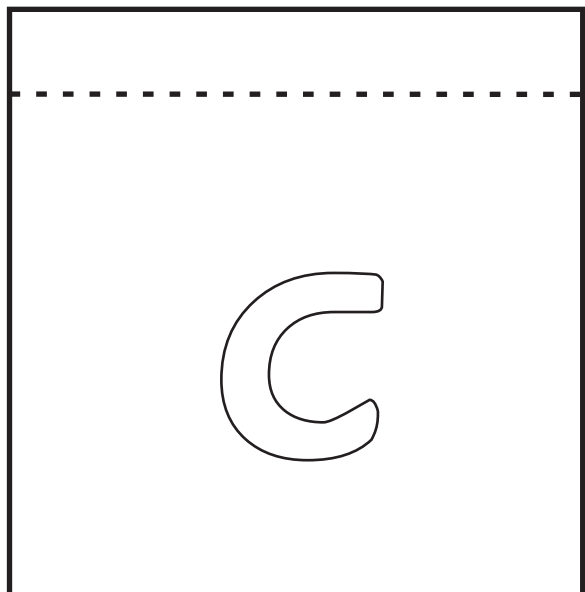
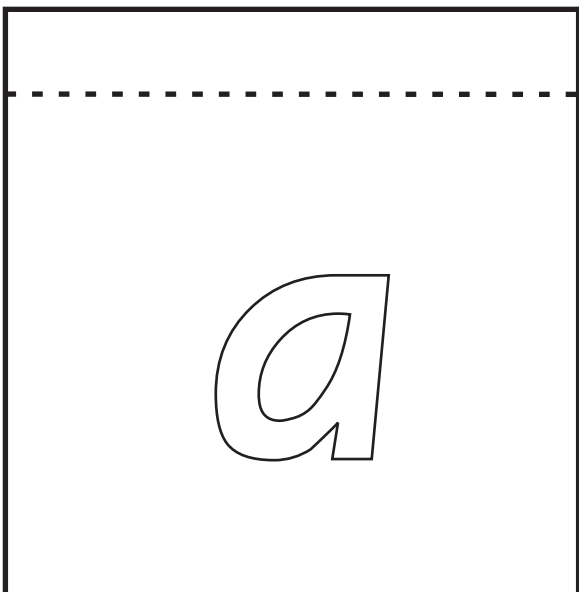
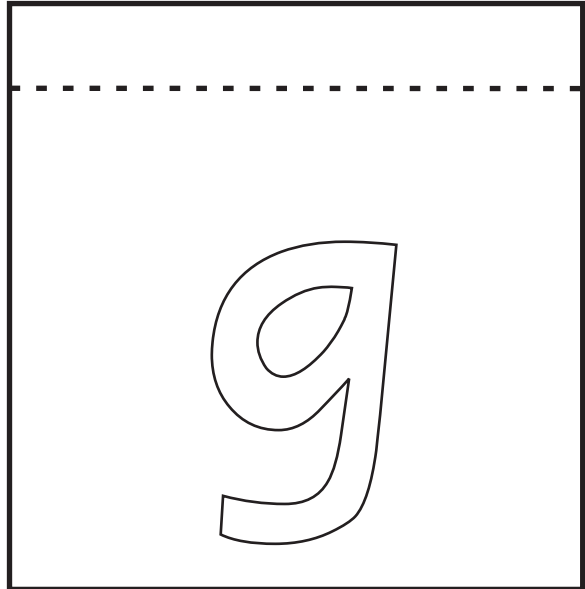
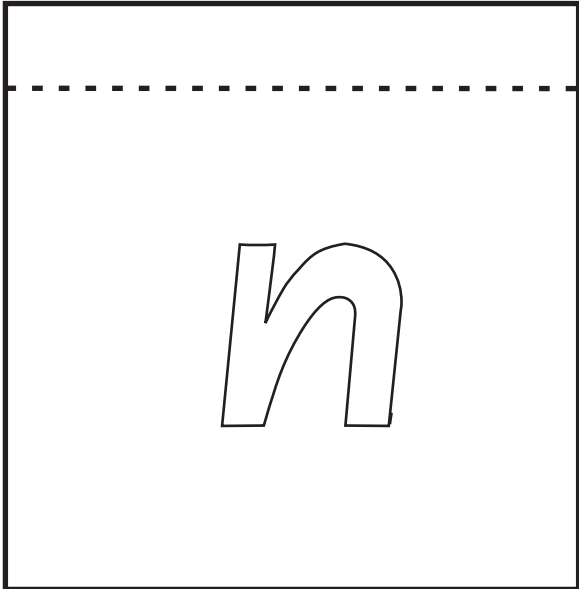
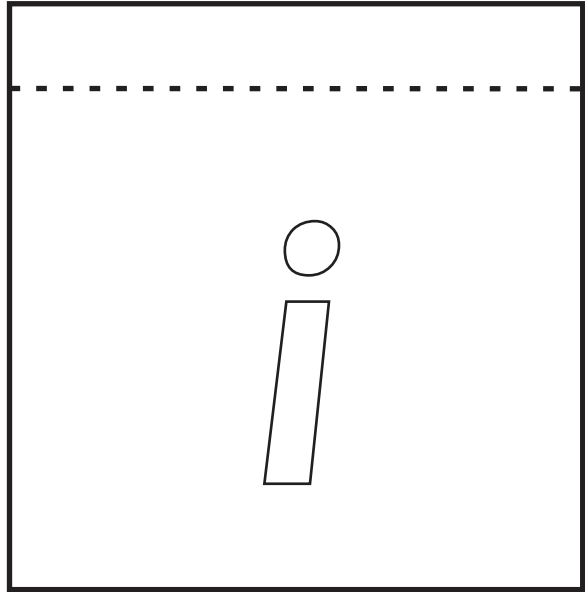
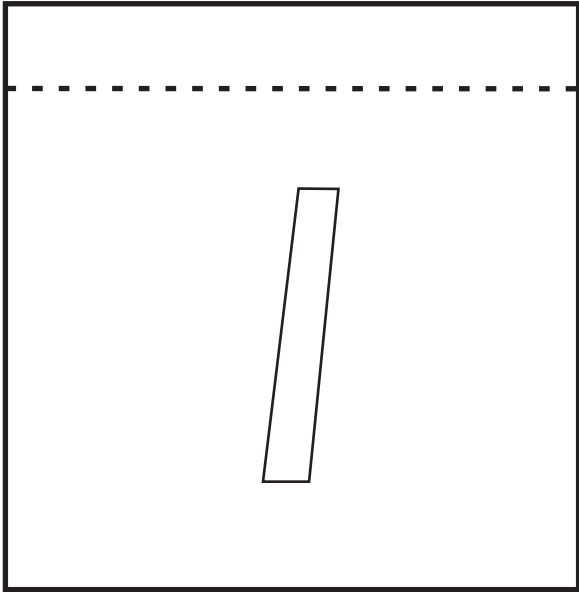

Name \_\_\_\_\_



Colour the pictures.  
Write the missing sounds.

Beginning, Middle, Final

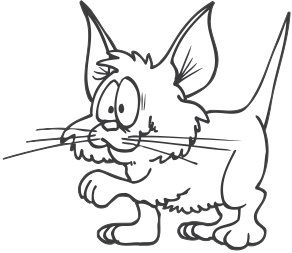

ca \_\_\_\_\_



\_\_\_\_\_urse

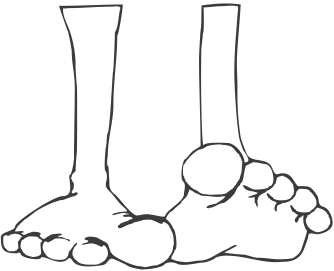

\_\_\_\_\_eet

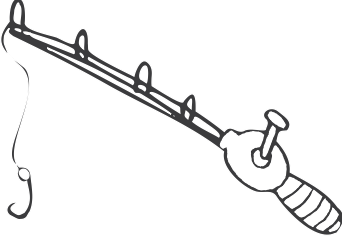

r \_\_\_\_\_d



b \_\_\_\_\_g



ru \_\_\_\_\_

Name \_\_\_\_\_

Trace the sounds. Cut out the squares.  
Paste them onto the picture squares.



Beginning, Middle, Final

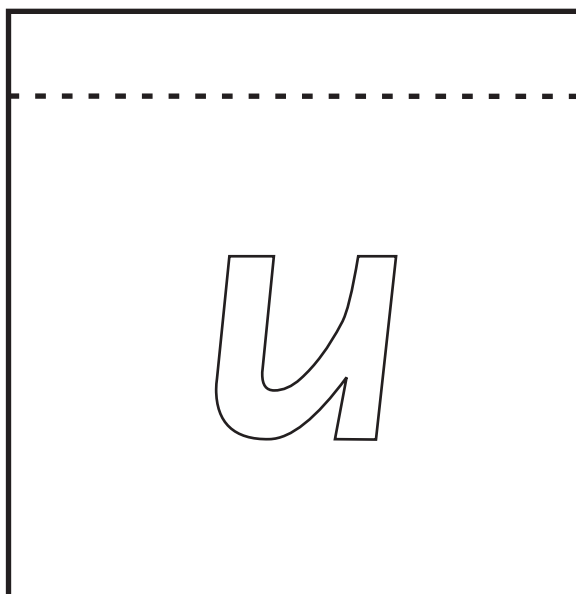
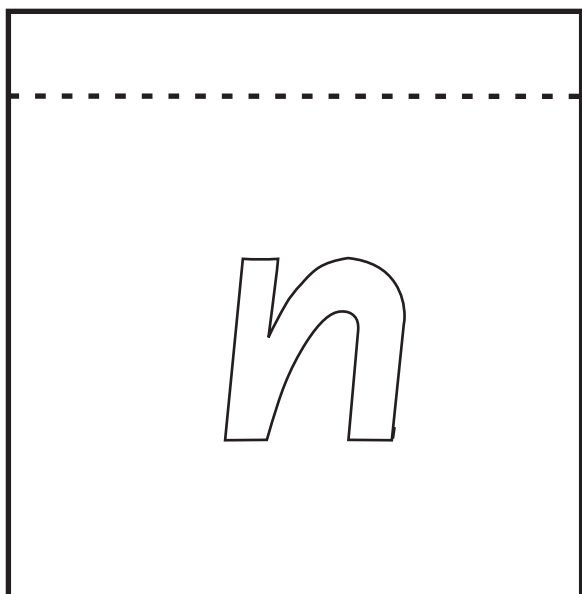
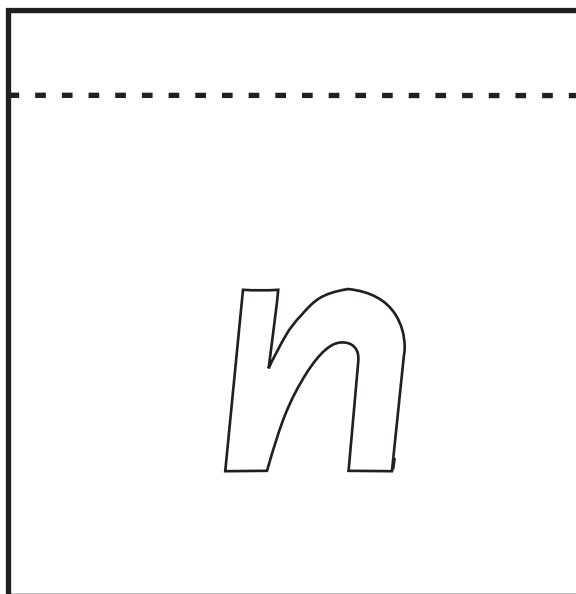
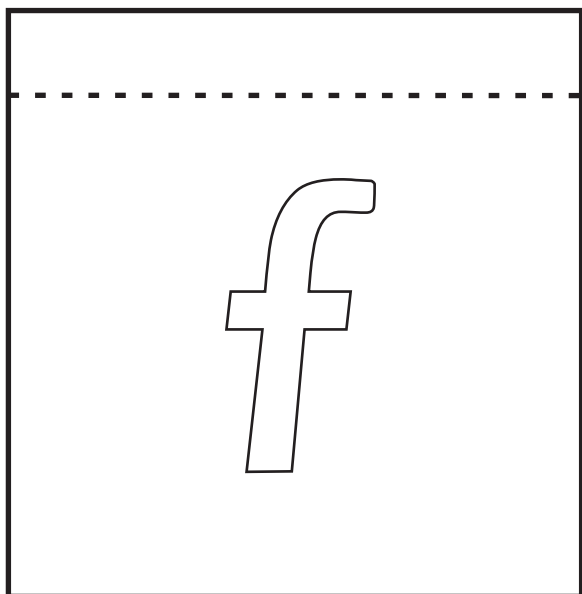
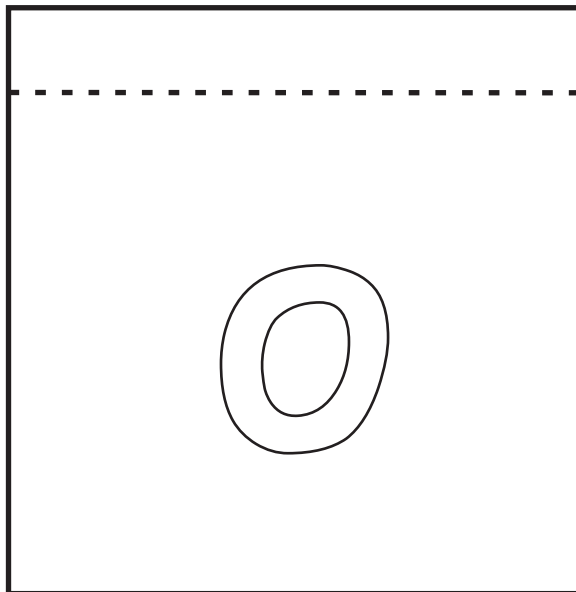
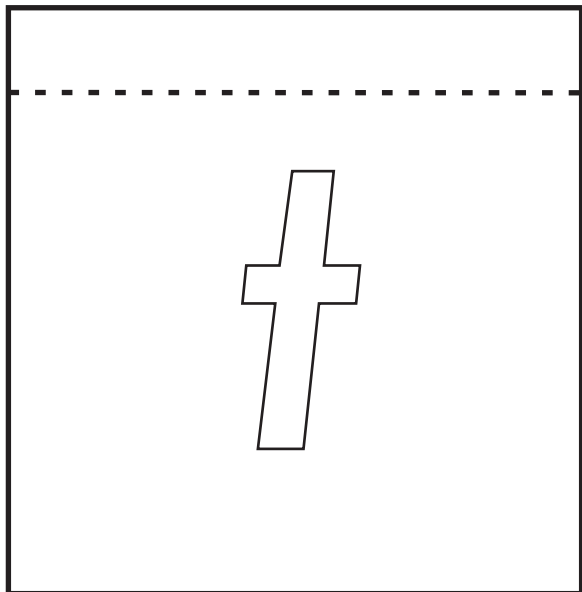

*The following pages contain templates suitable for the classroom teacher to expand this program by modifying the font to match their state.*

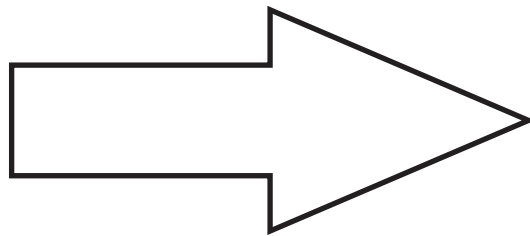

*Photocopy, cut out and paste over the letters on the previous pages that are unsuitable for your state.*

*These pages can also be used with the blank templates at the back of this book.*

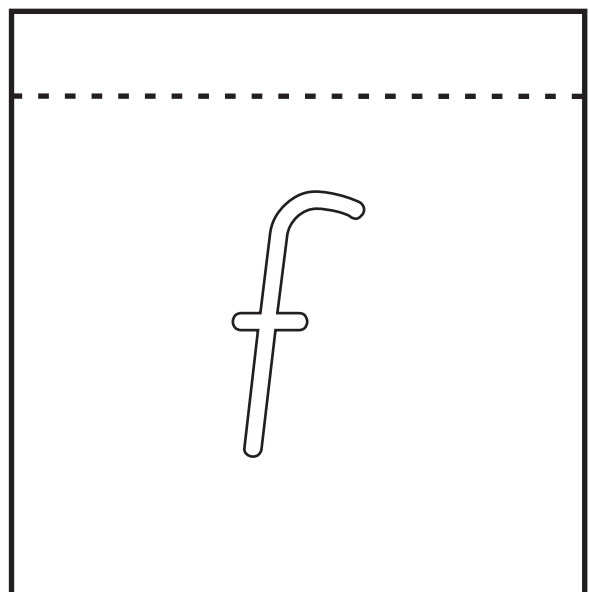
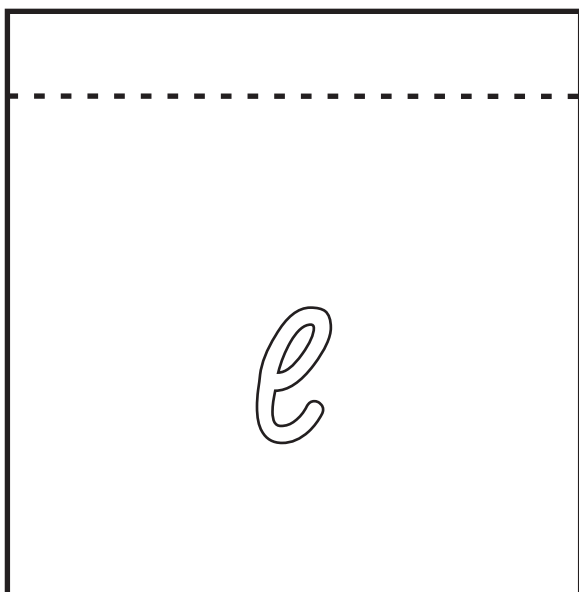
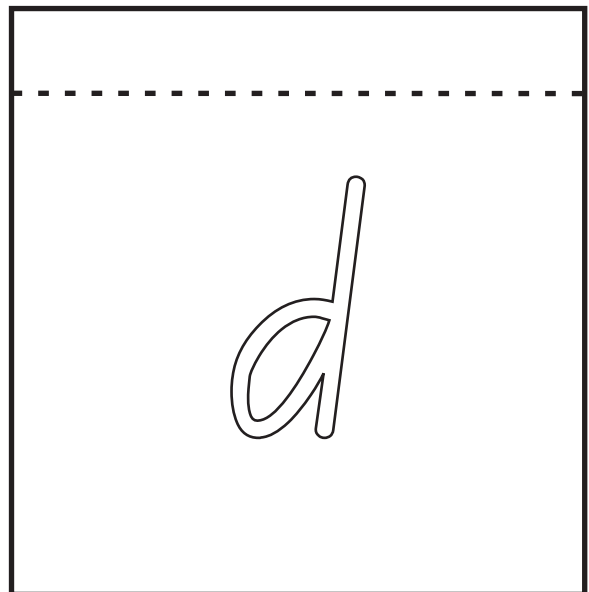
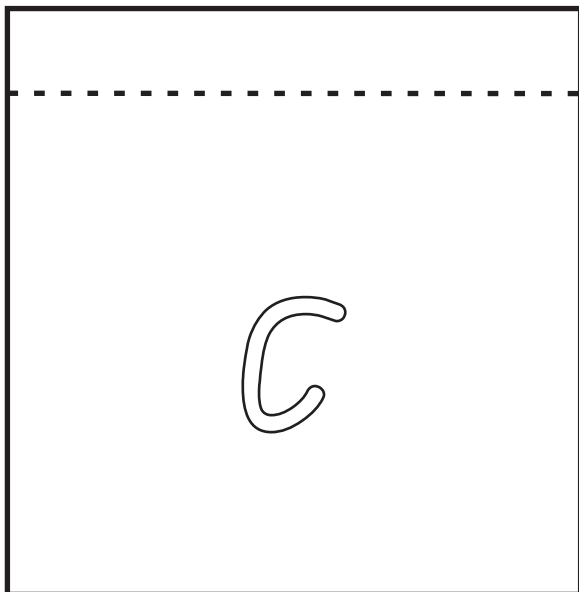
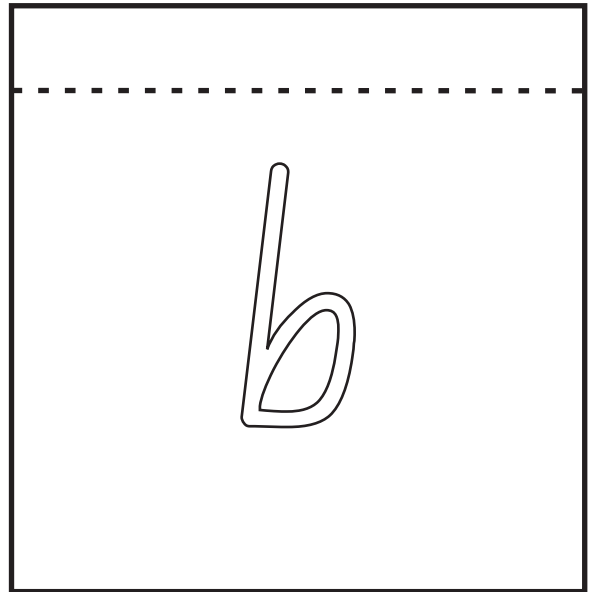
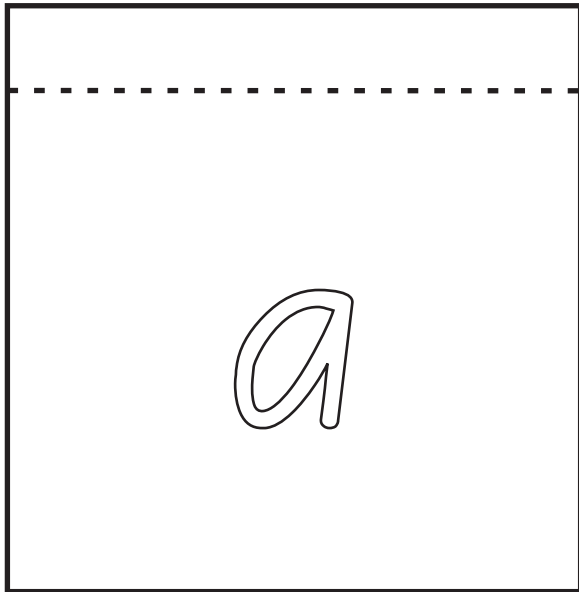

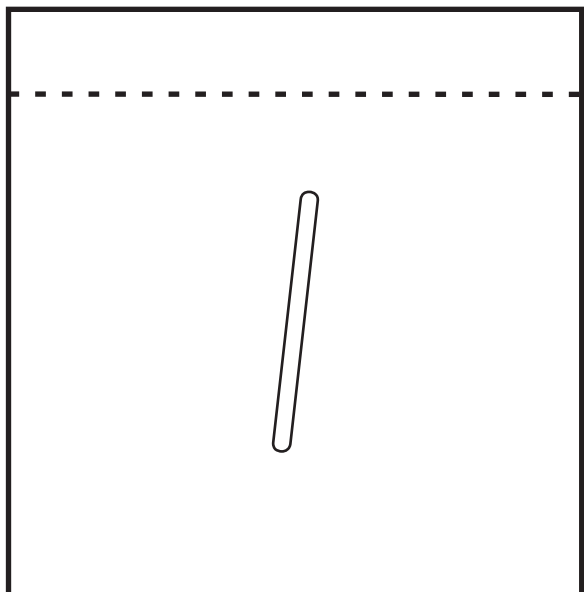
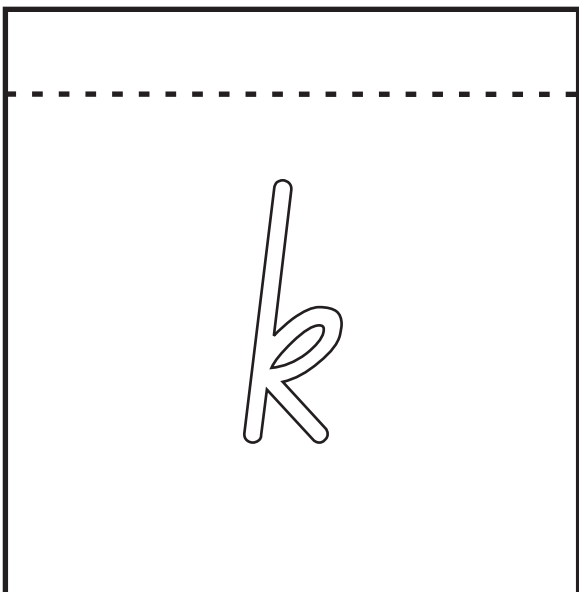
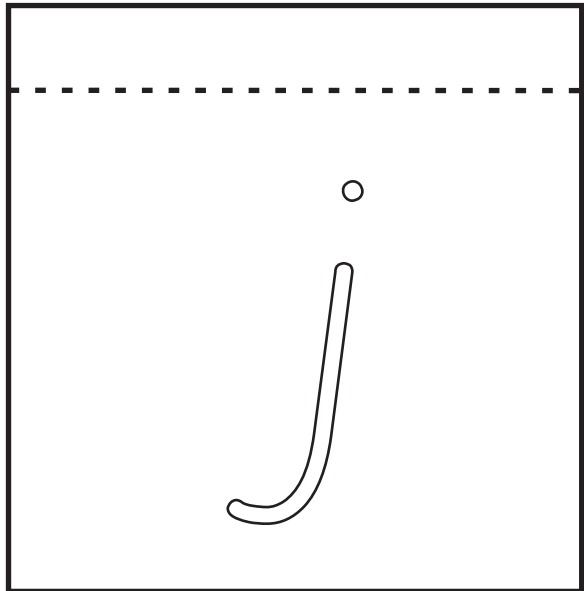
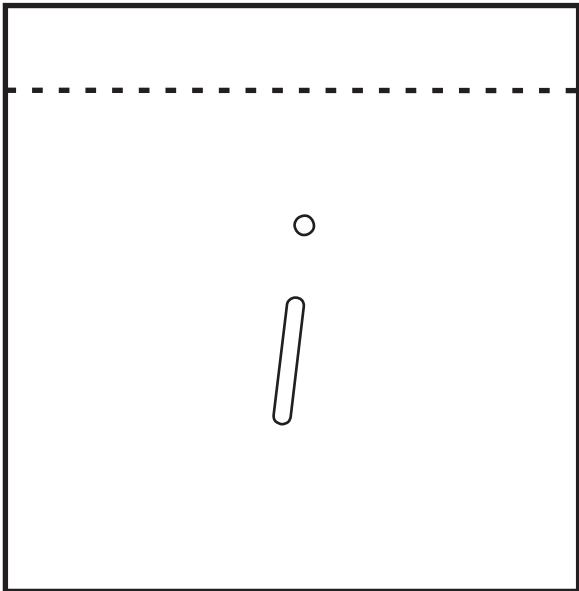
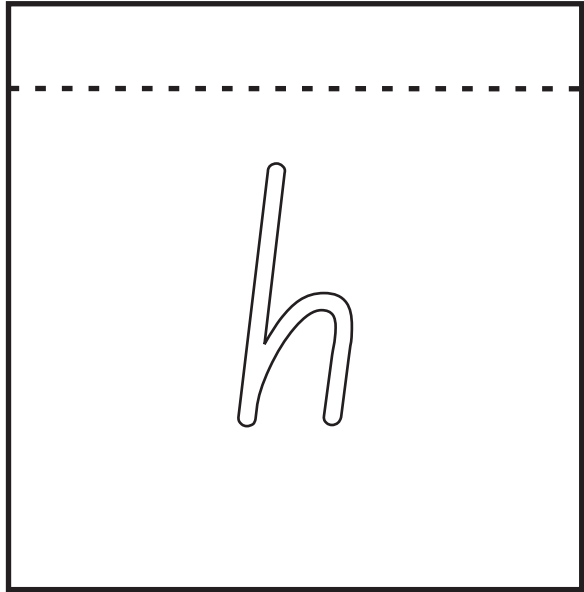
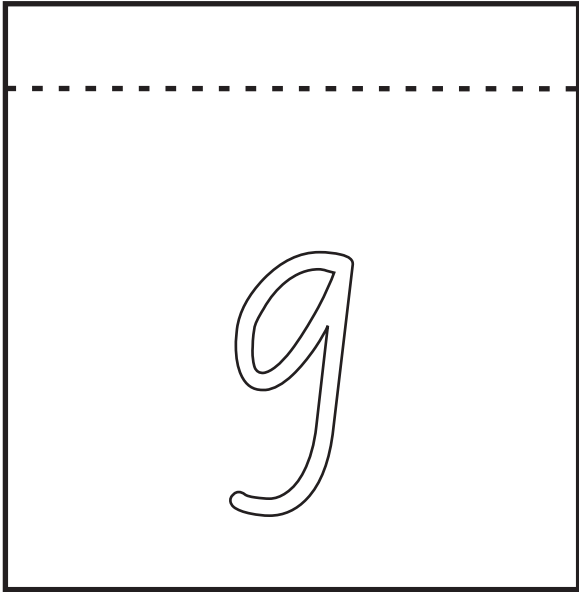

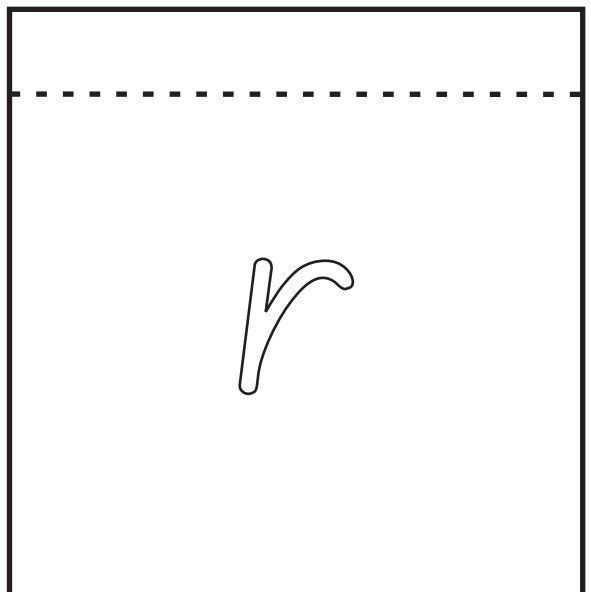
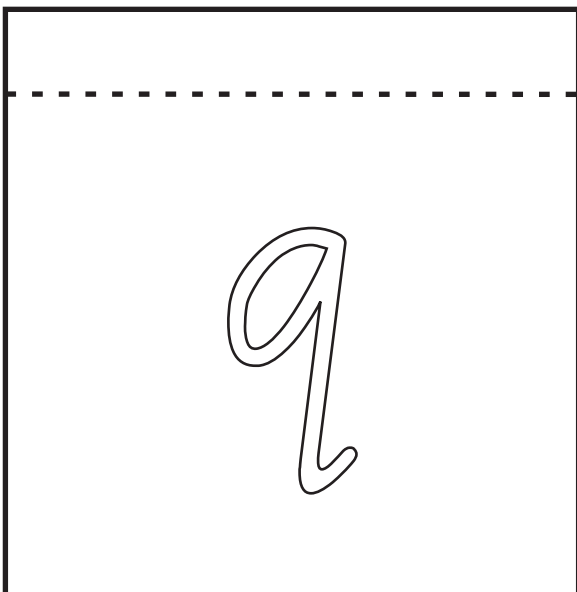
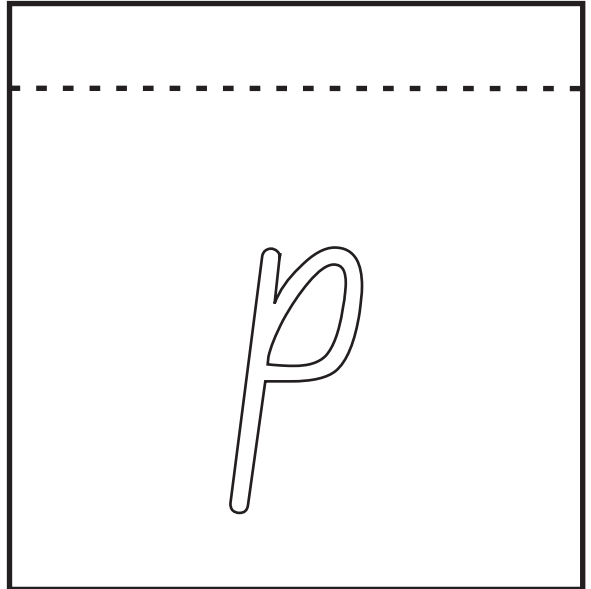
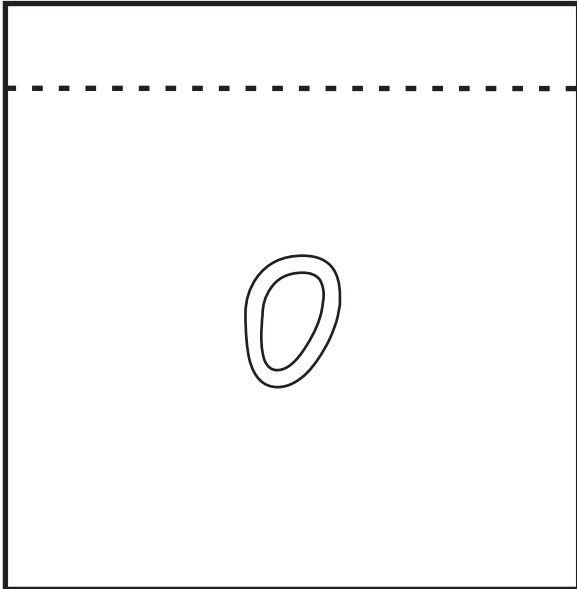
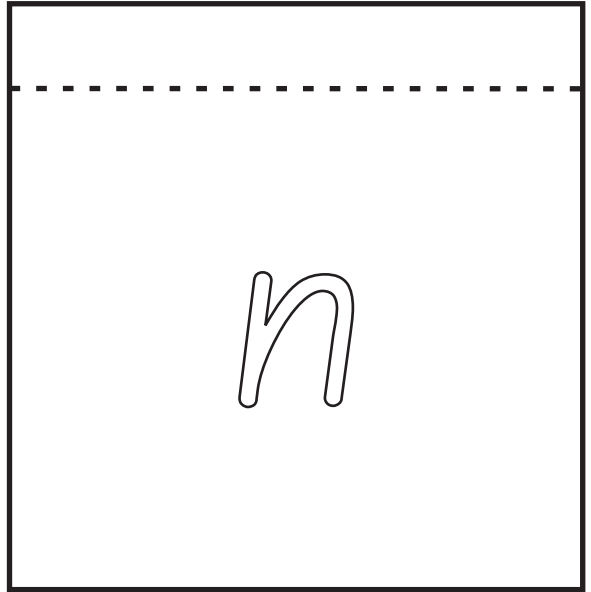
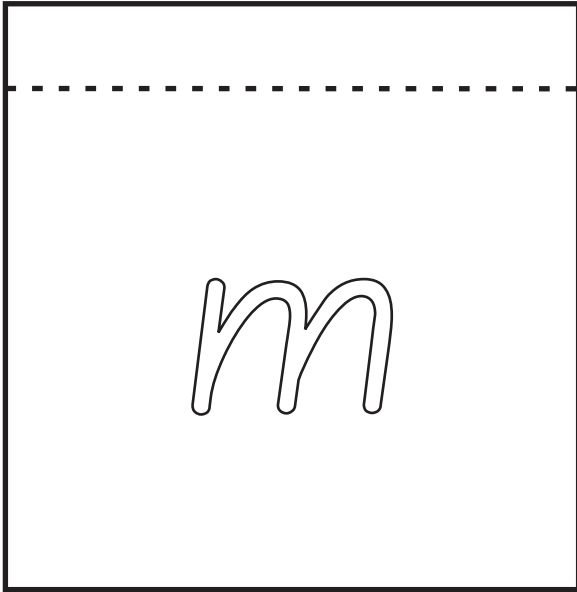



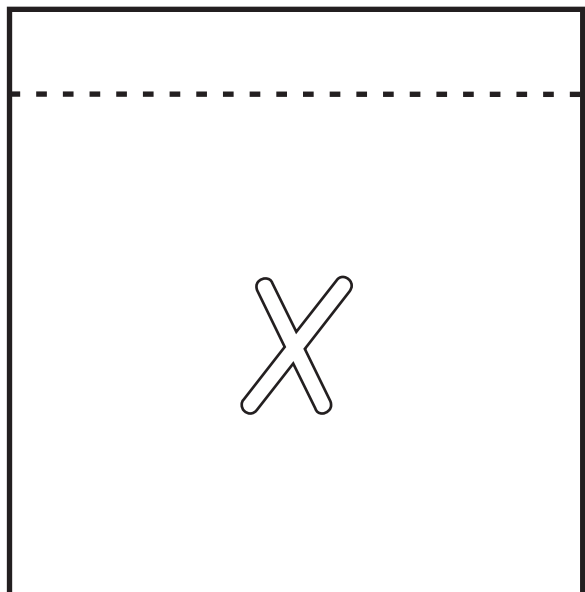
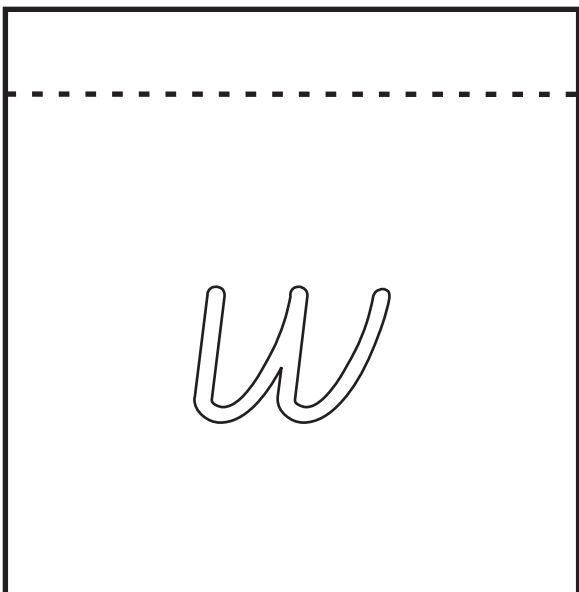
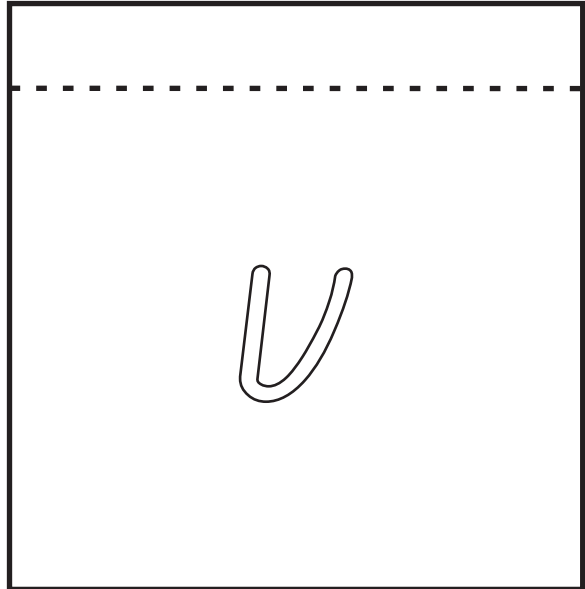
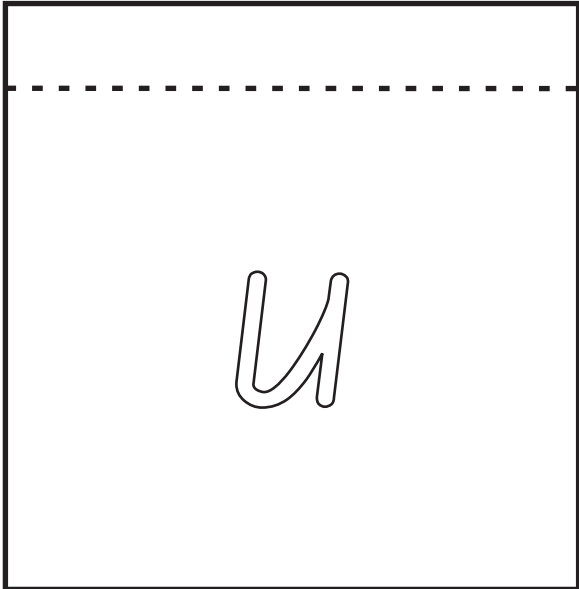
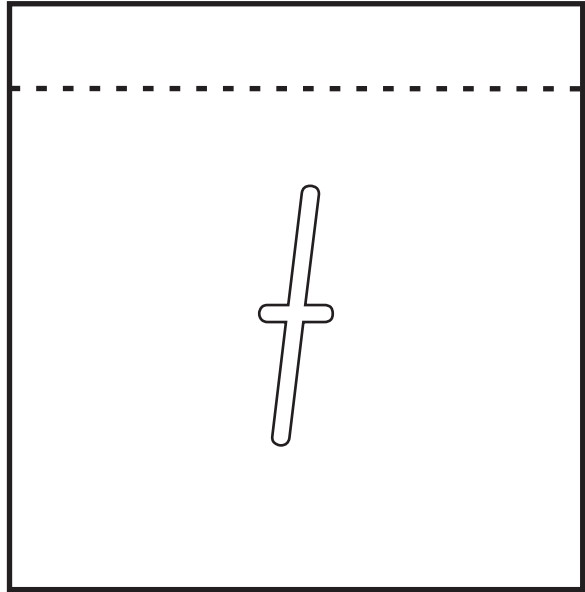
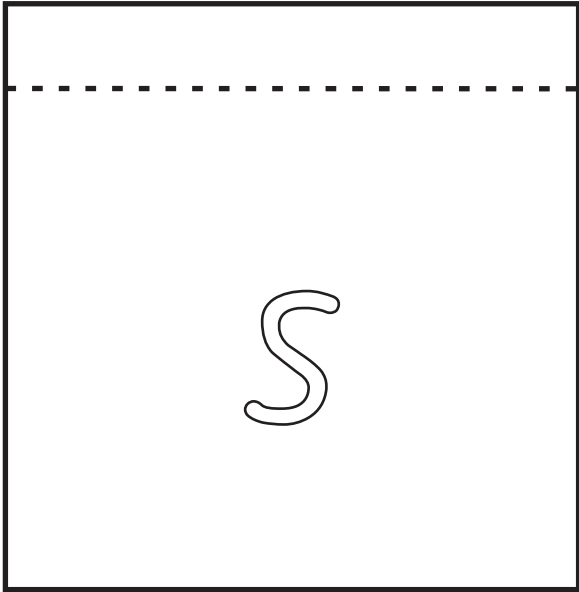

N.S.W. Foundation

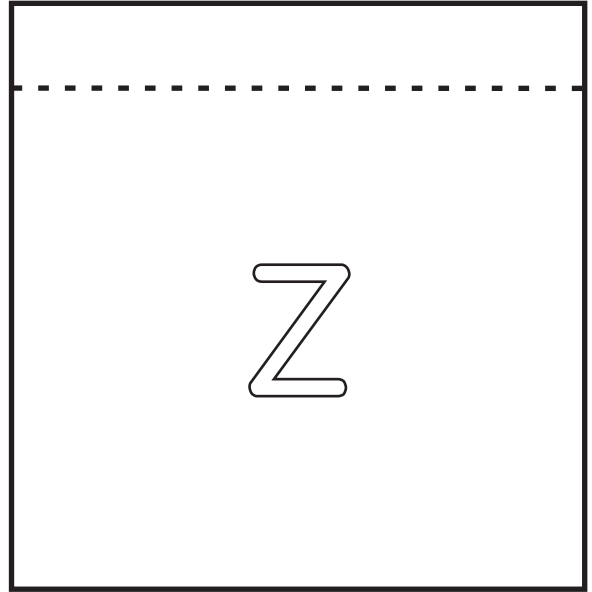
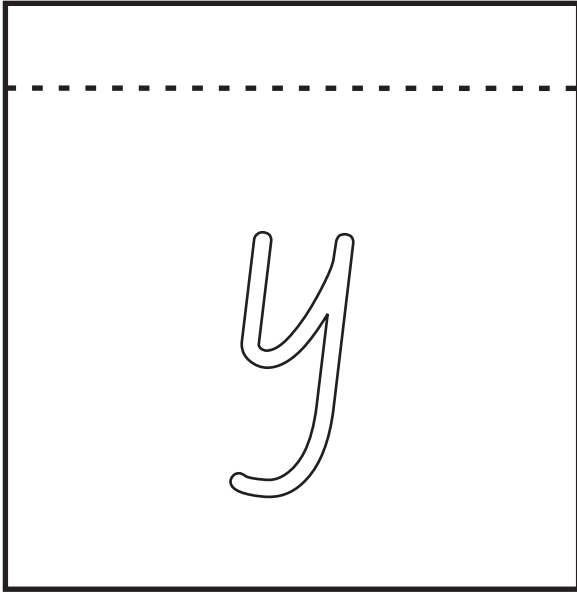

Victorian Modified Cursive

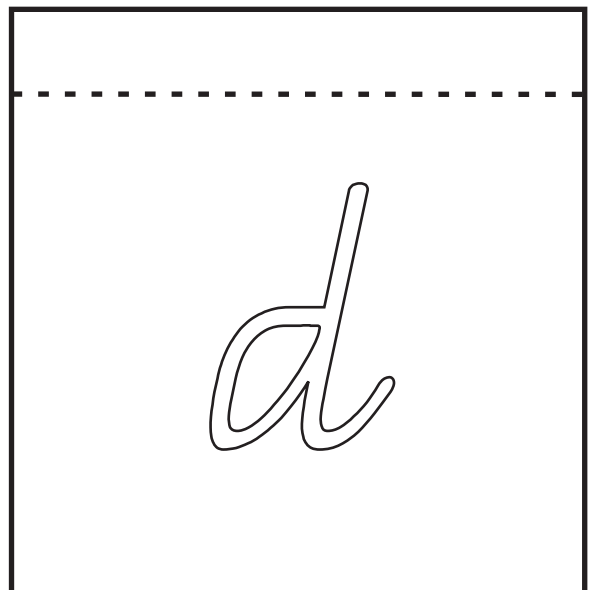
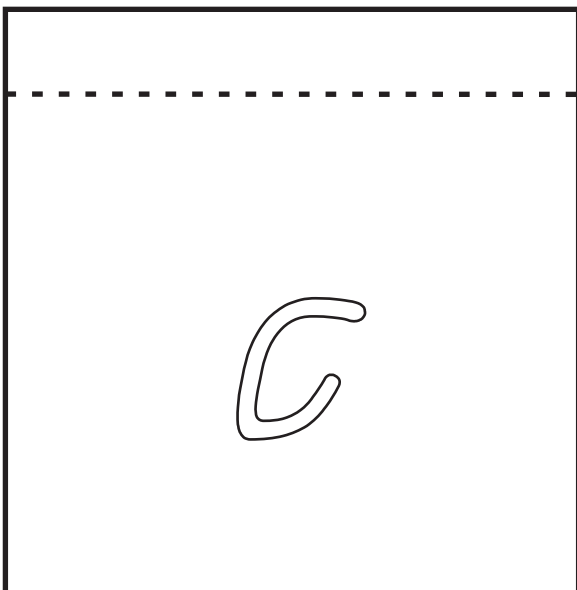
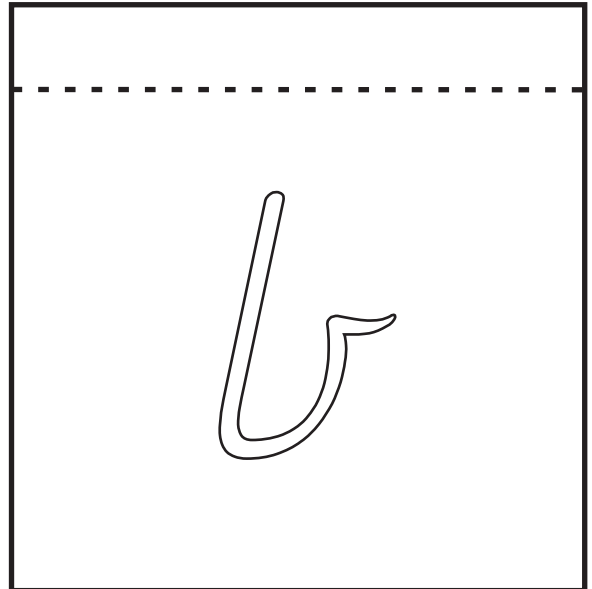
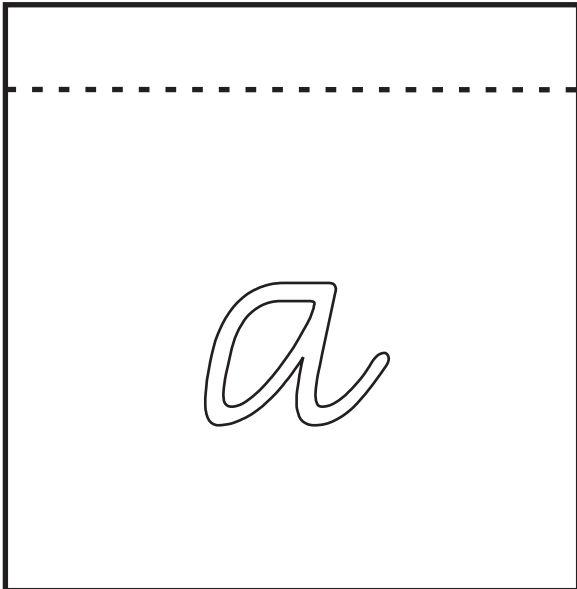

Victorian Modified Cursive

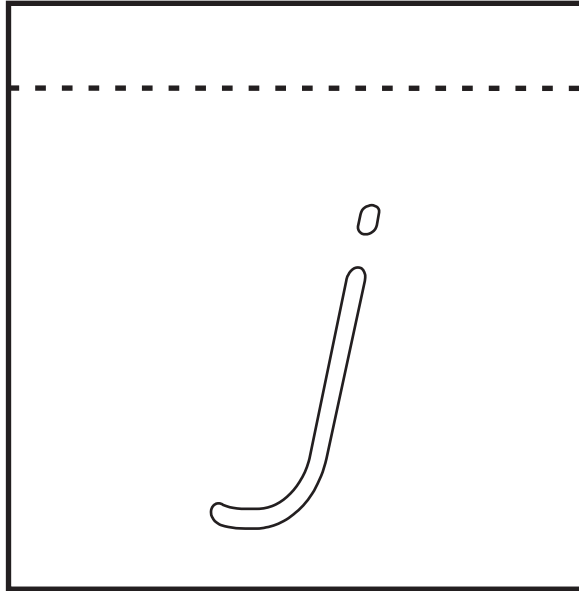
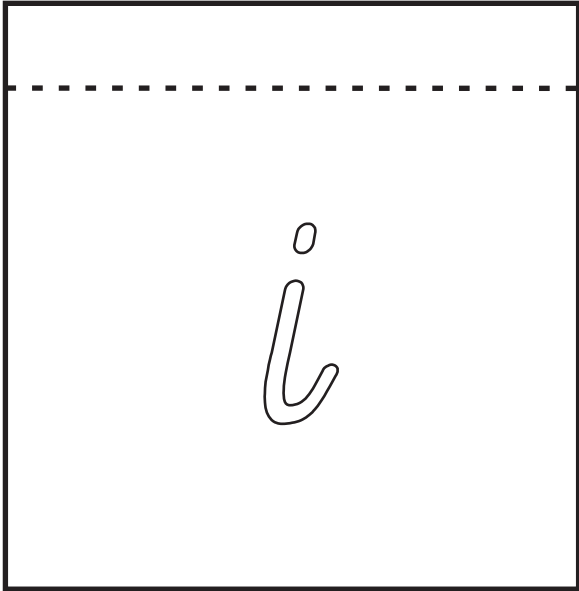
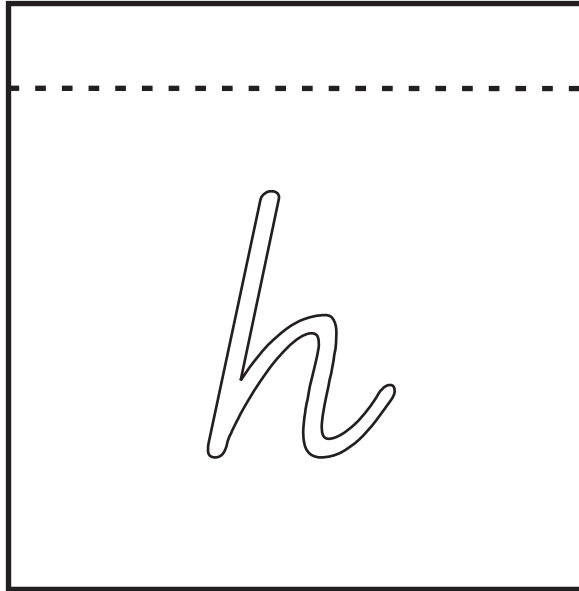
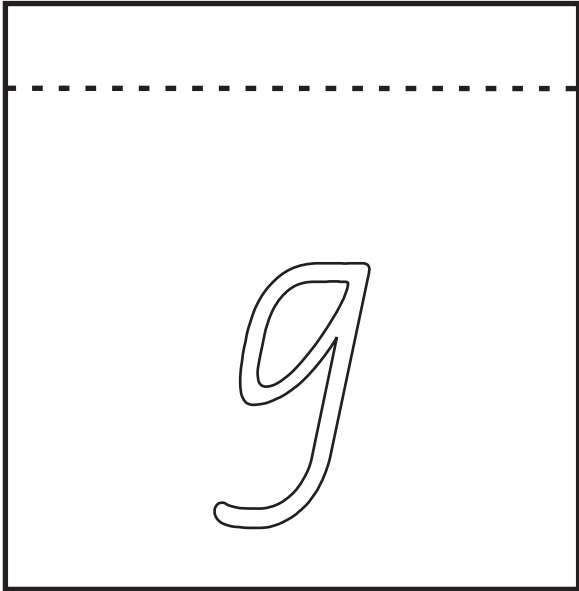
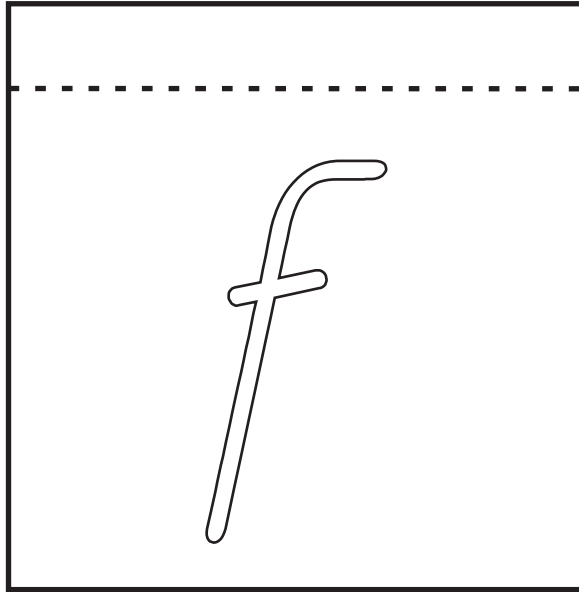
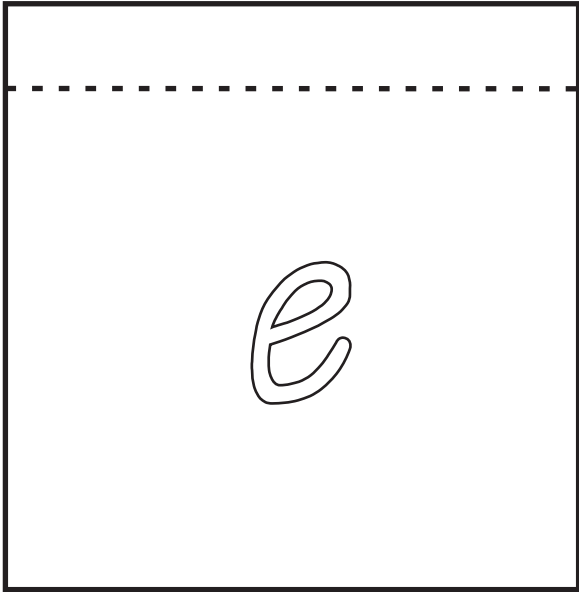

Victorian Modified Cursive

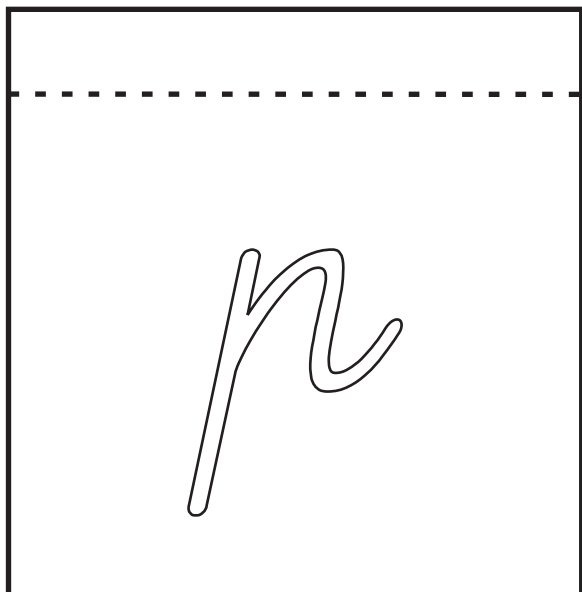
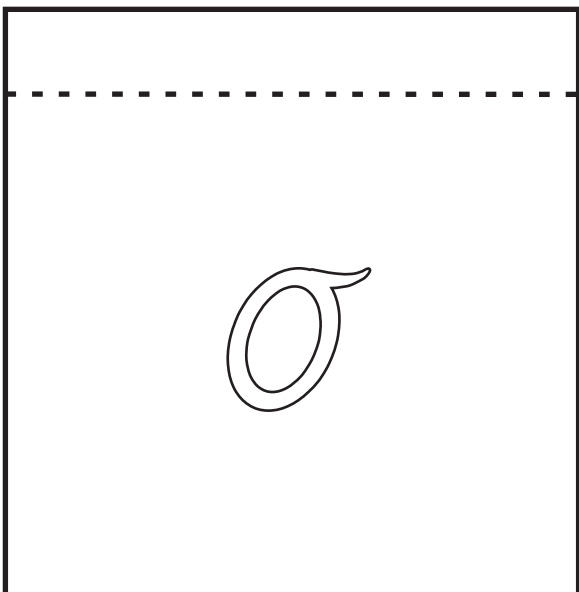
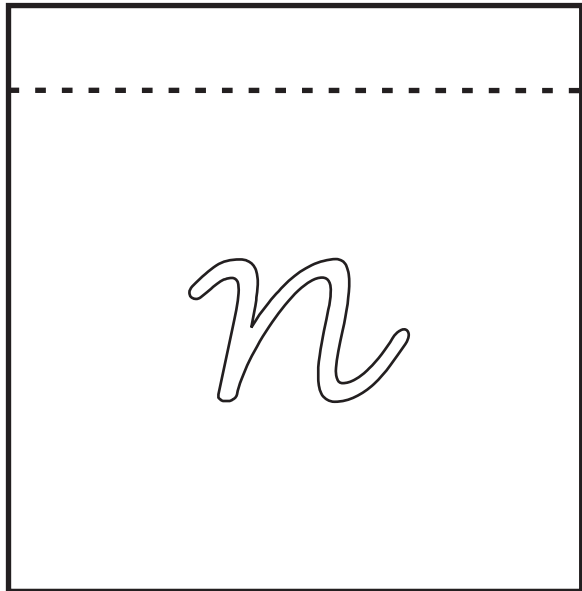
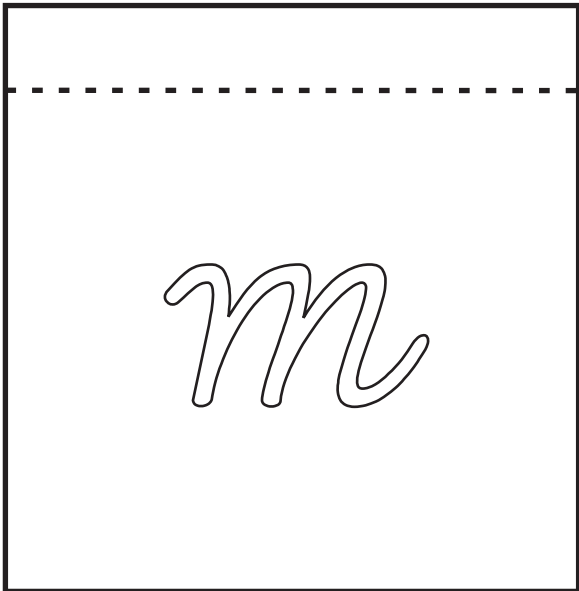
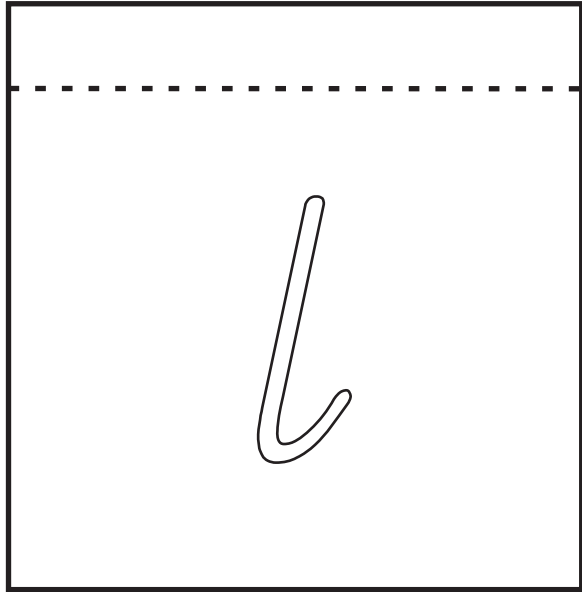
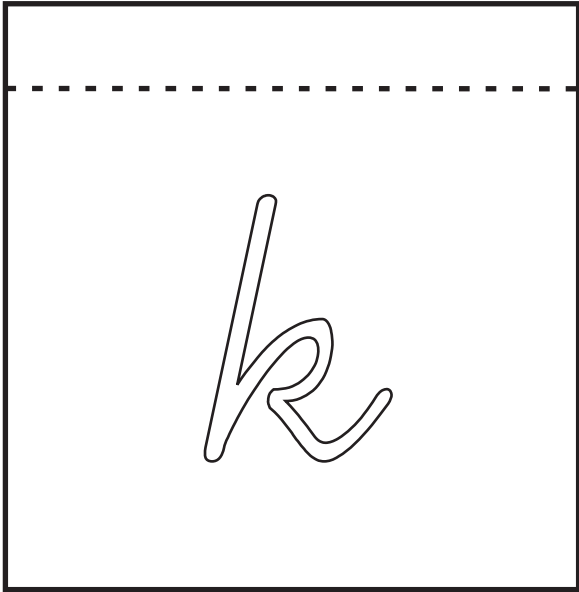

*Victorian Modified Cursive*

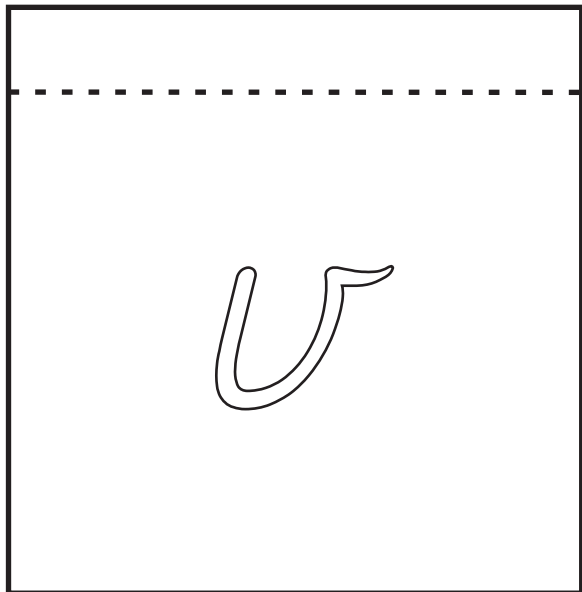
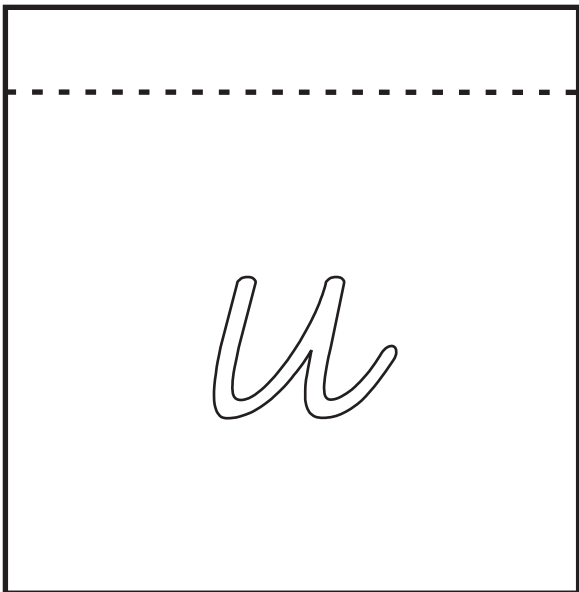
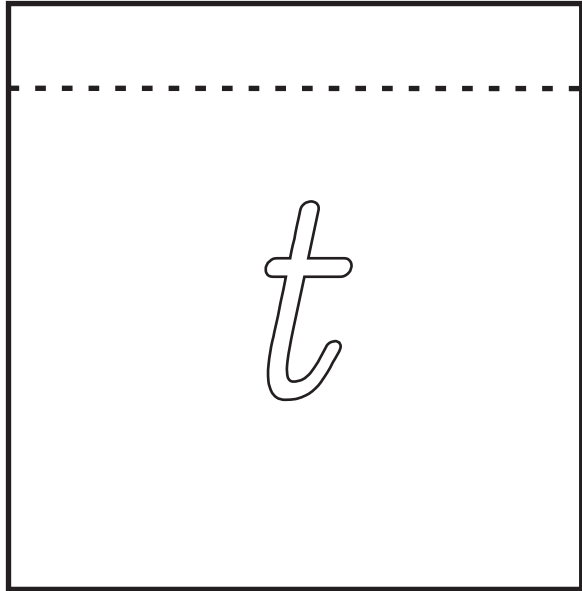
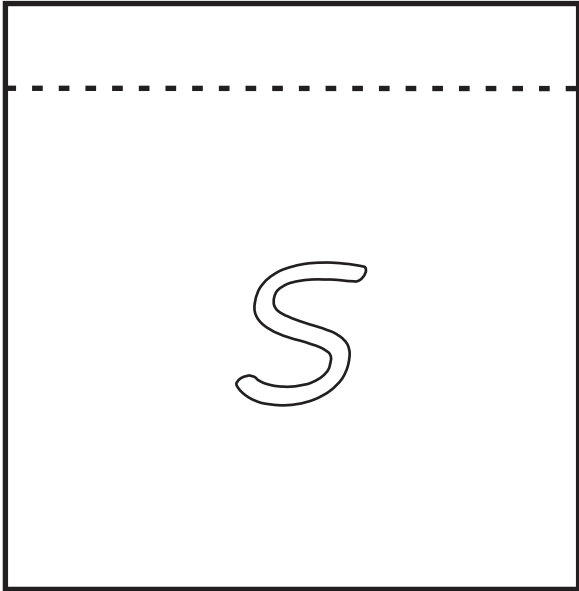
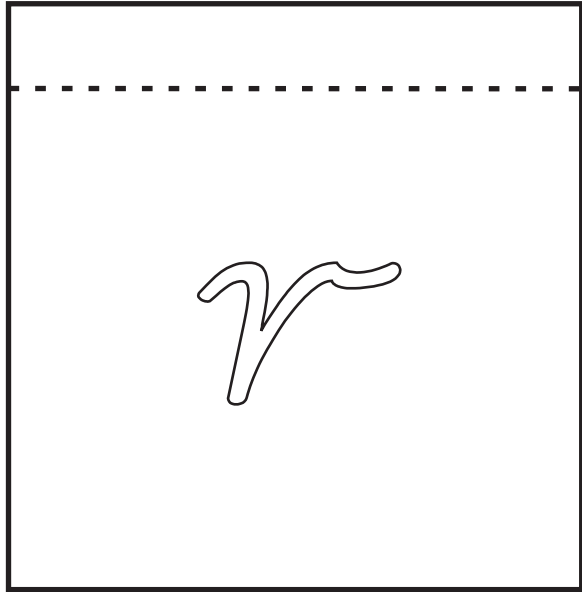
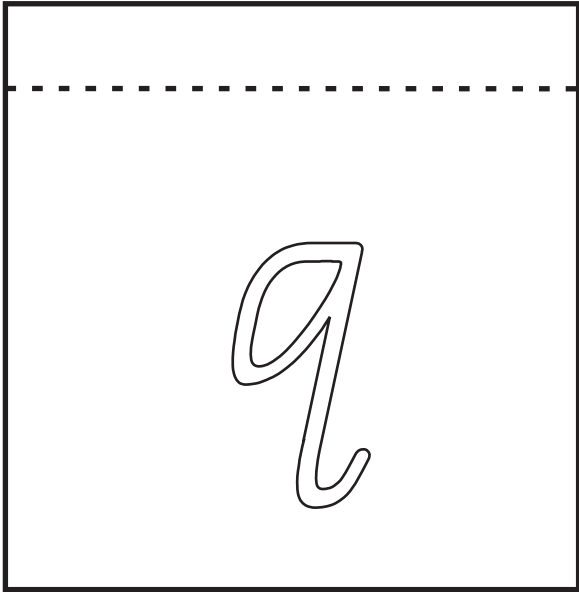

*Victorian Modified Cursive*

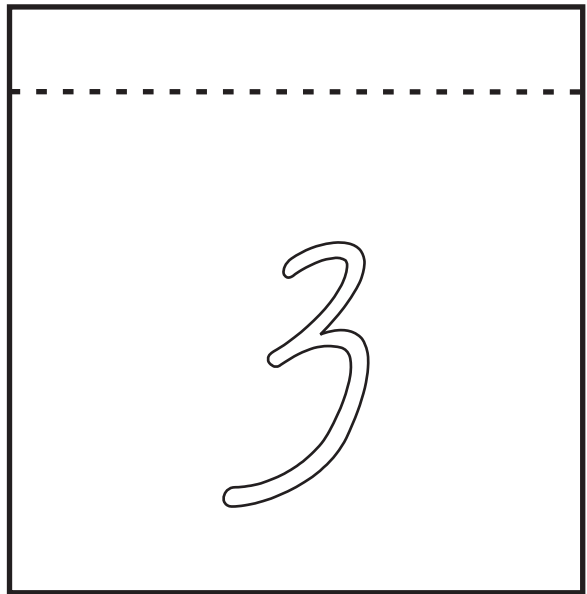
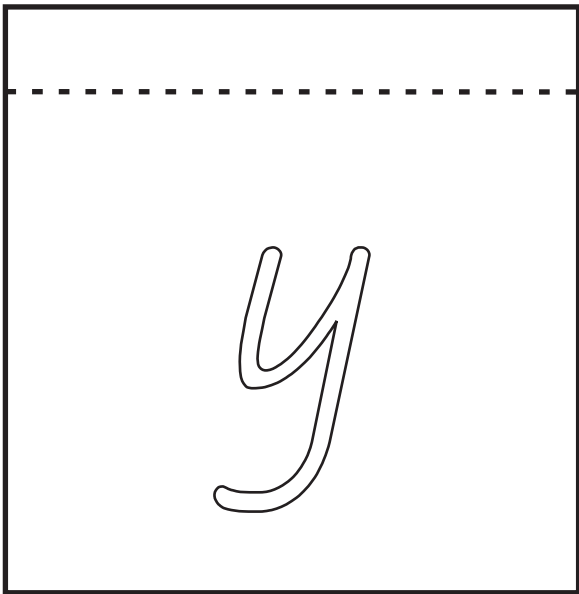
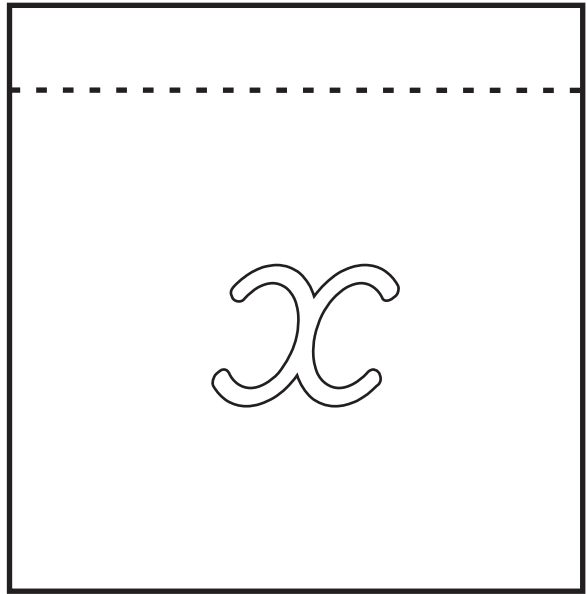
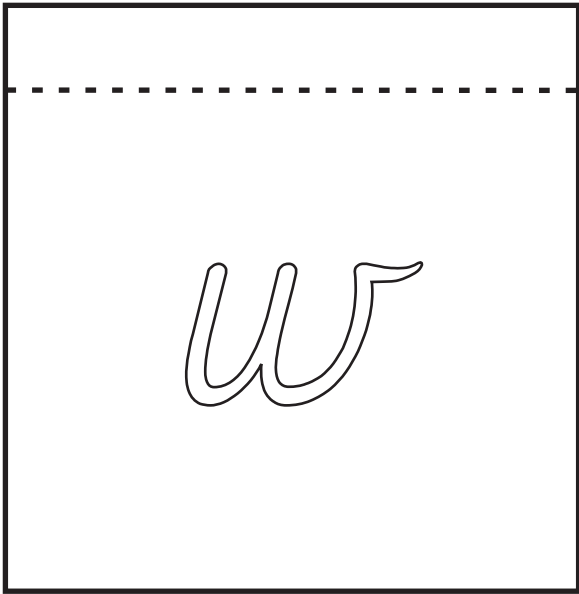

*Queensland Beginners*

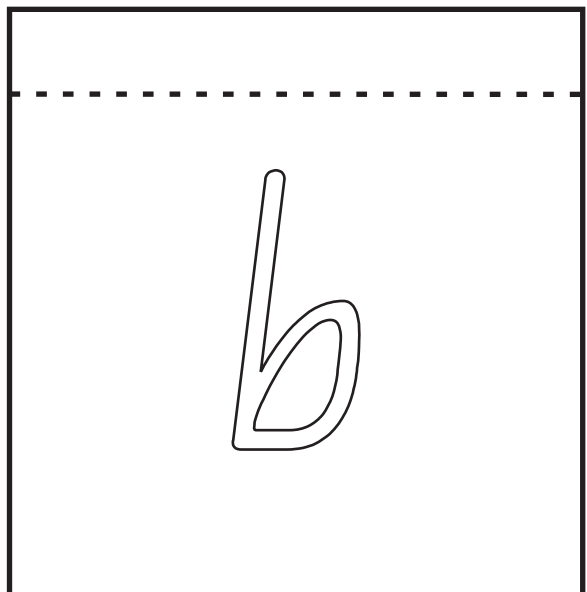
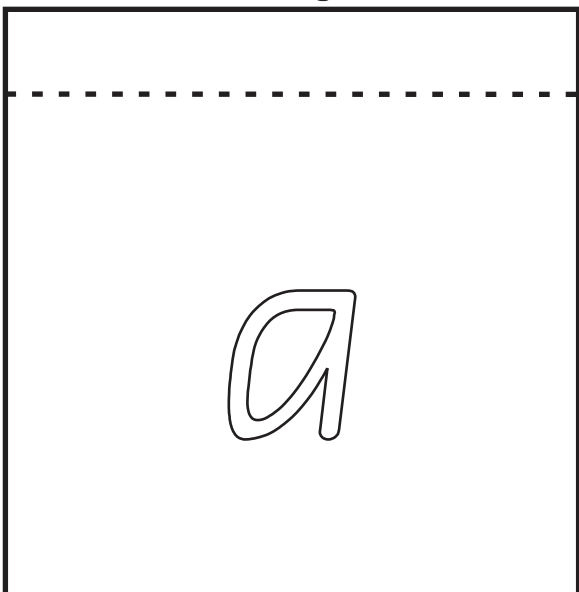

# Queensland Beginners

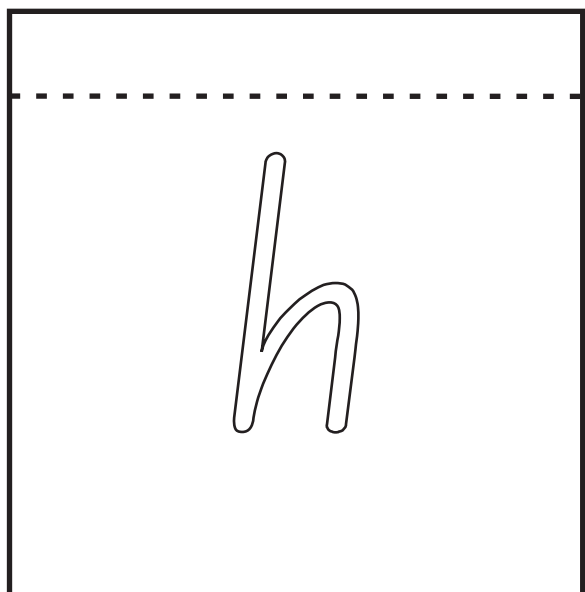
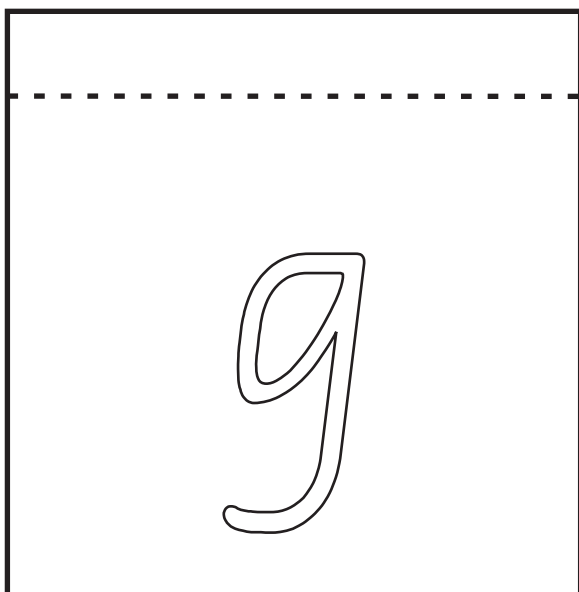
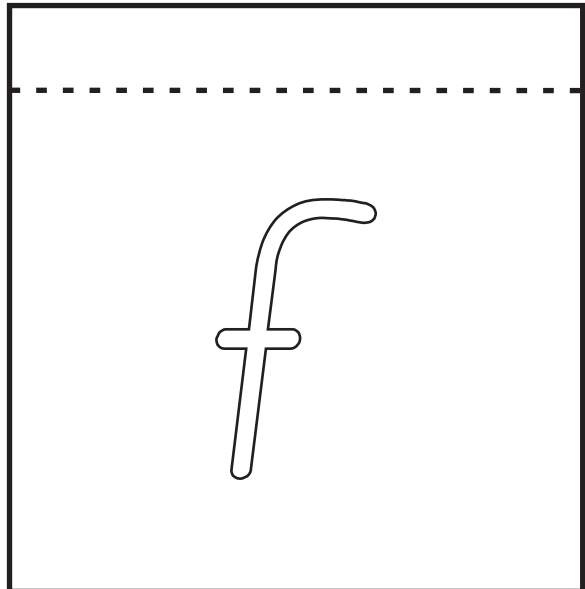
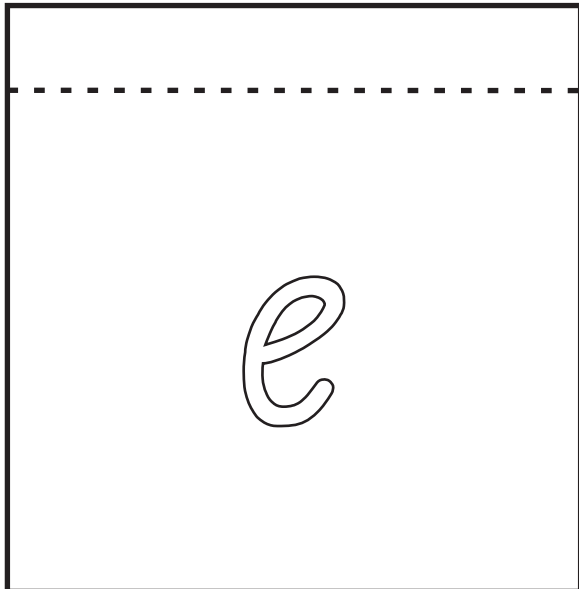
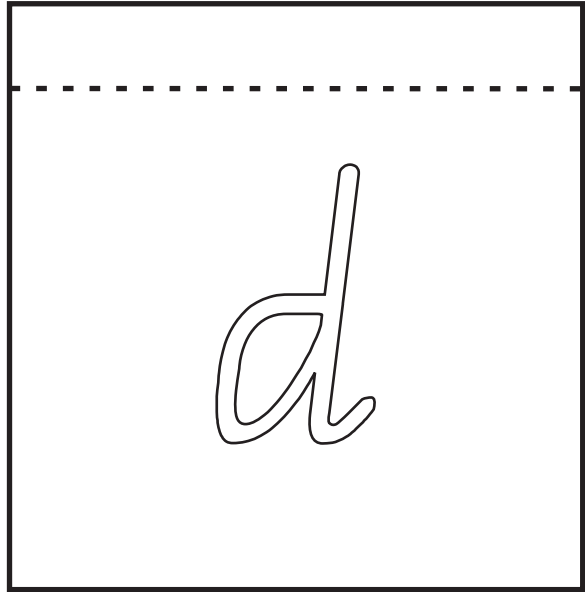
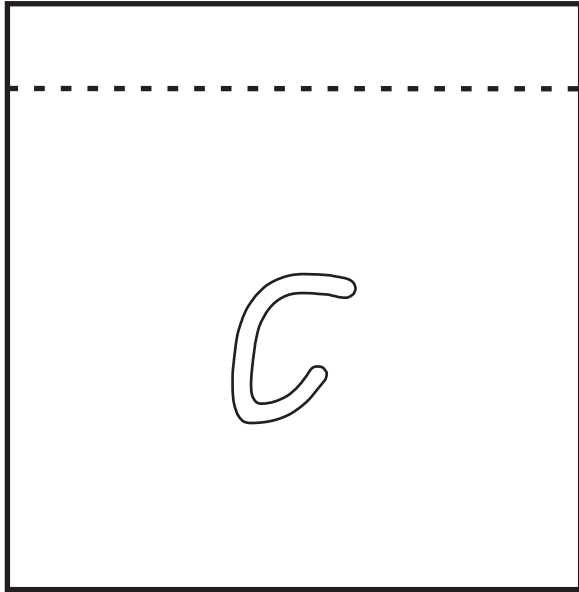

# Queensland Beginners

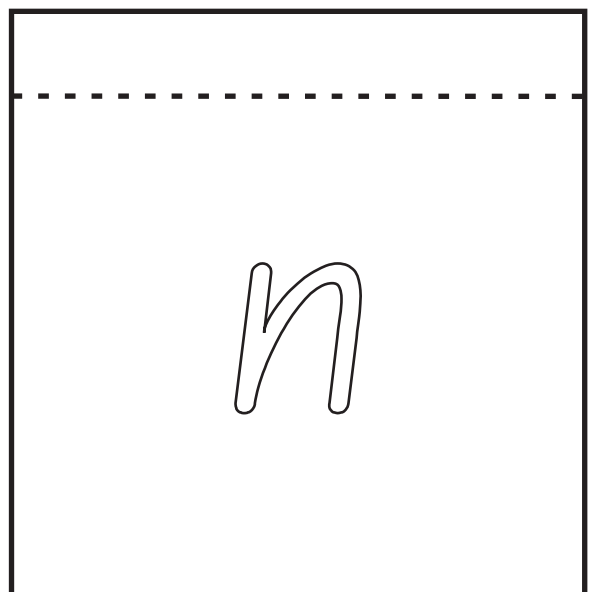
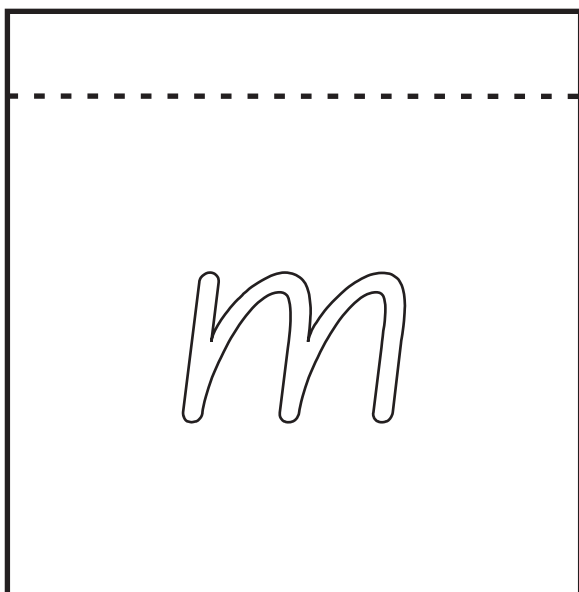
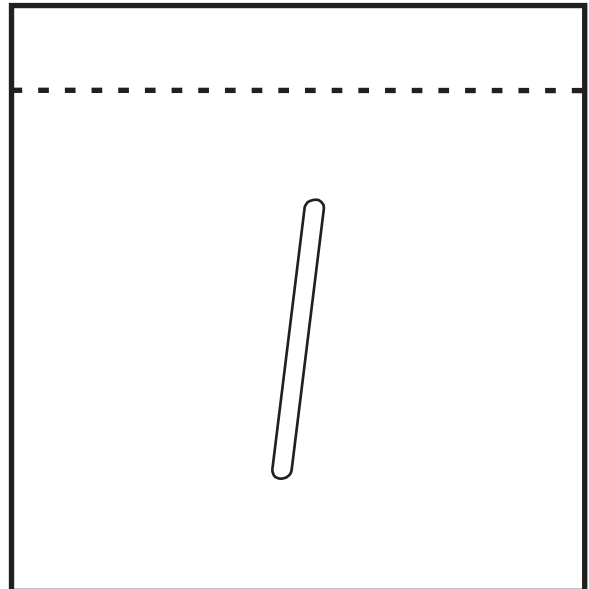
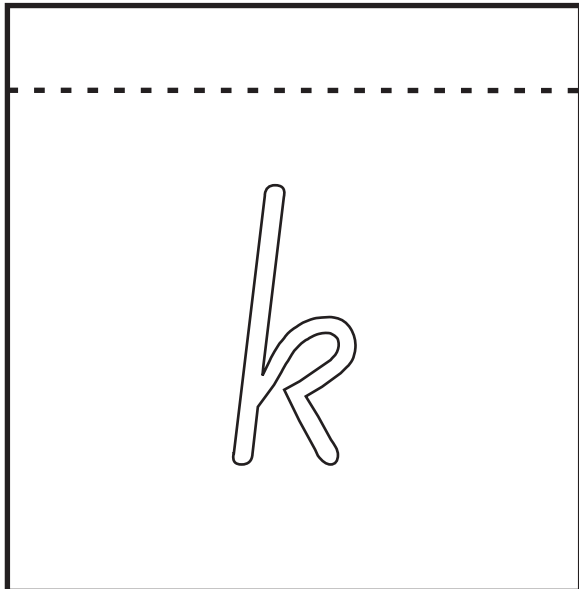
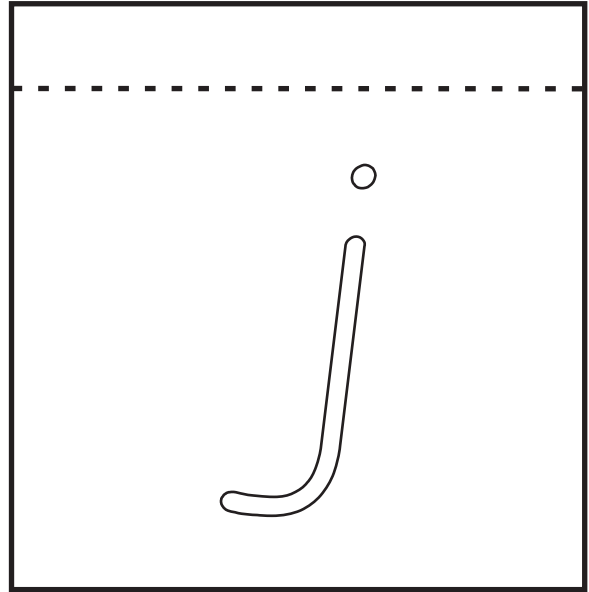
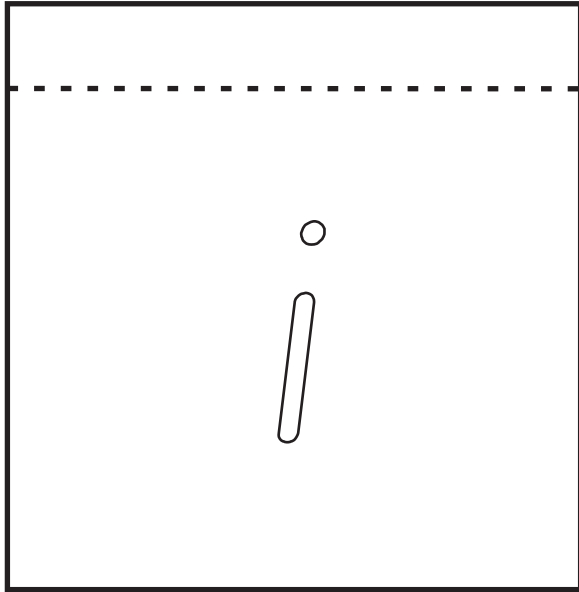



# Queensland Beginners

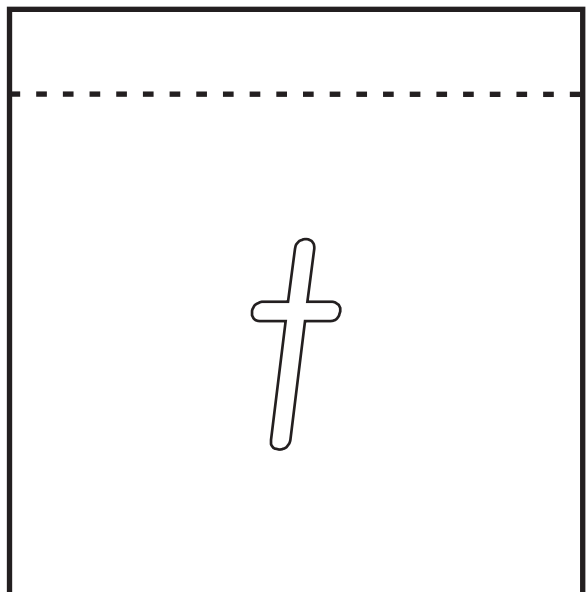
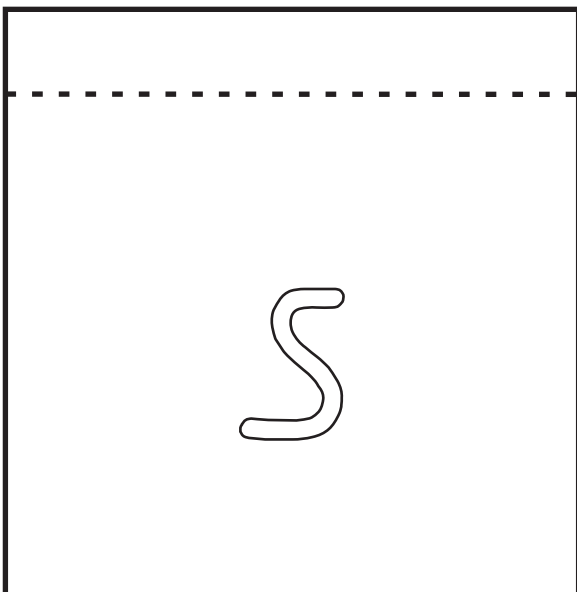
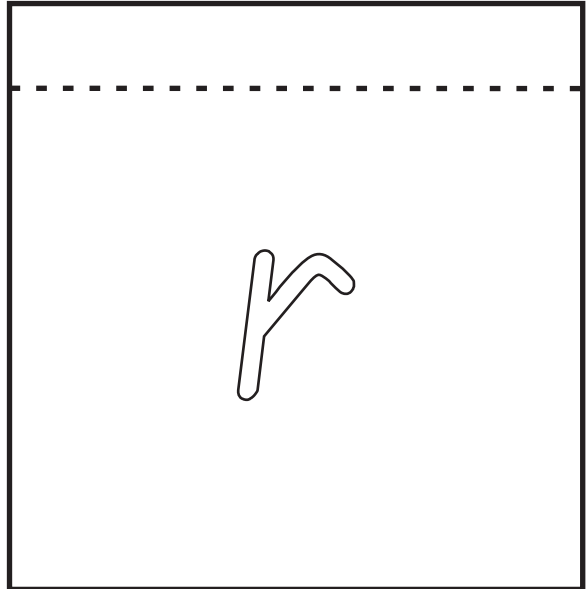
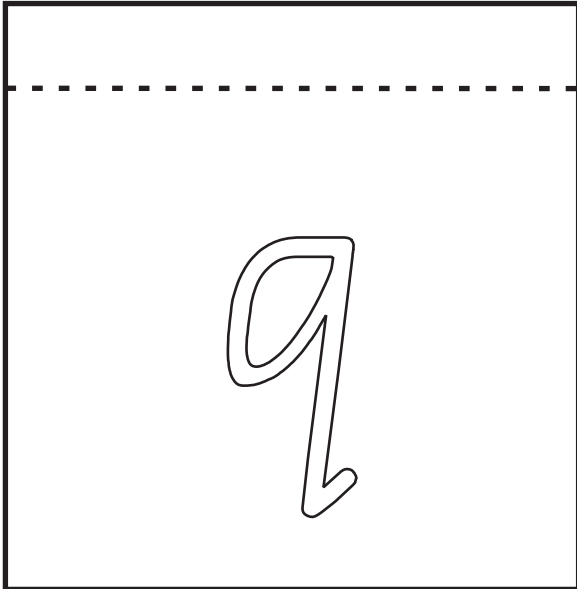
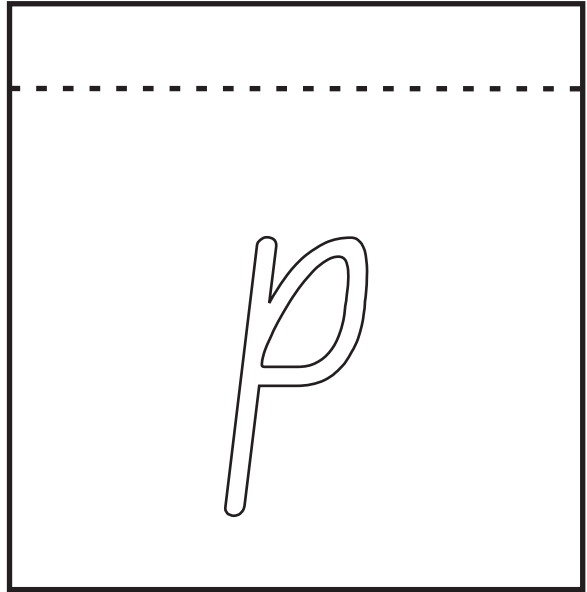
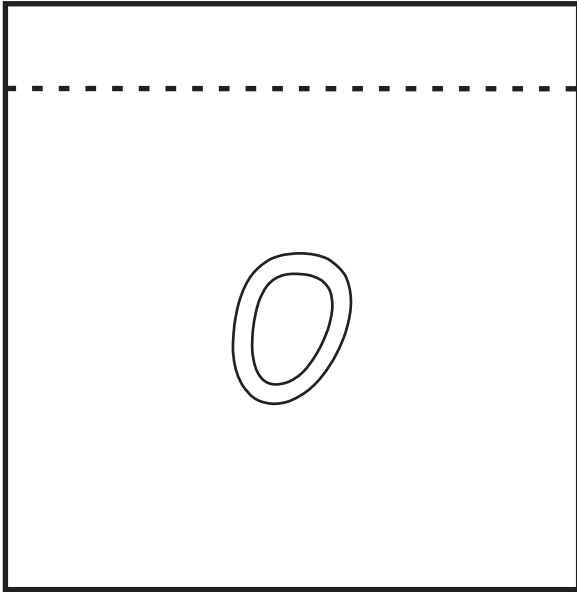

# Queensland Beginners

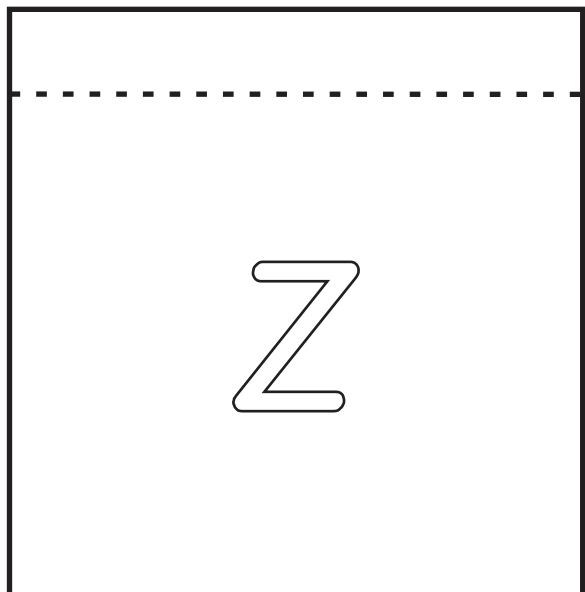
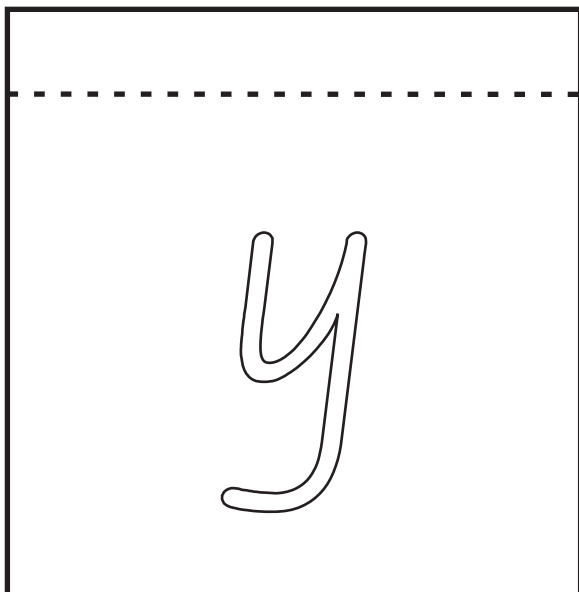
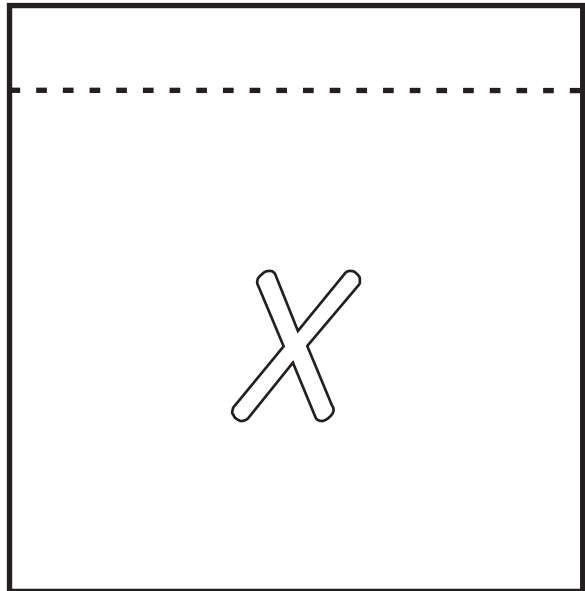
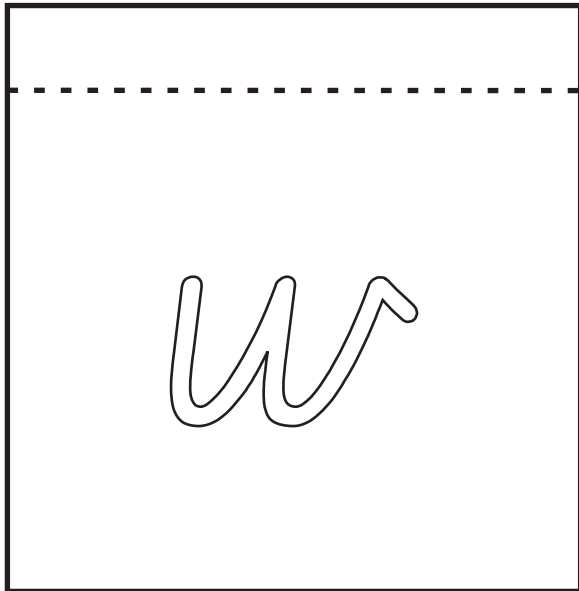
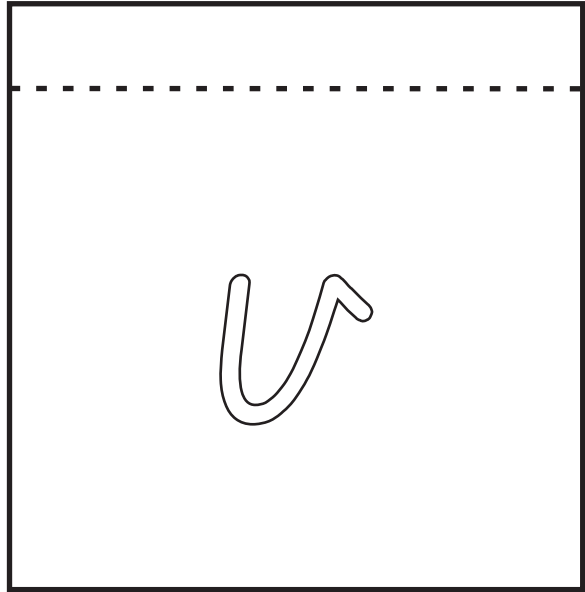
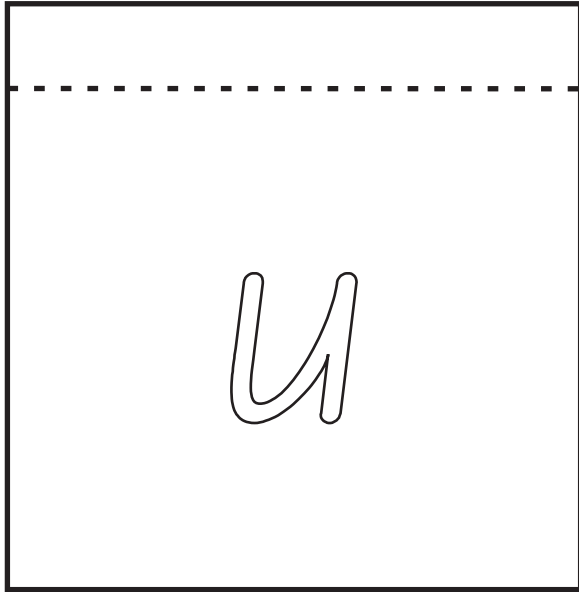

*The following pages contain templates suitable for the classroom teacher to expand this program.*

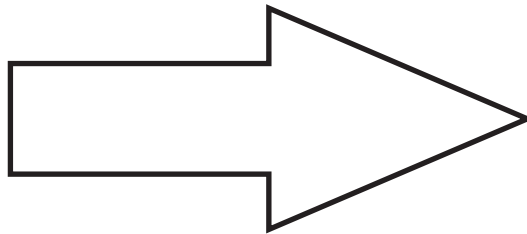

*These templates can be used to create other activities which will re-inforce the recognition of single sounds e.g. the teacher or students can write their own sounds on the cards and then draw a picture of something with that sound or cut out pictures from magazines.*

Name \_\_\_\_\_

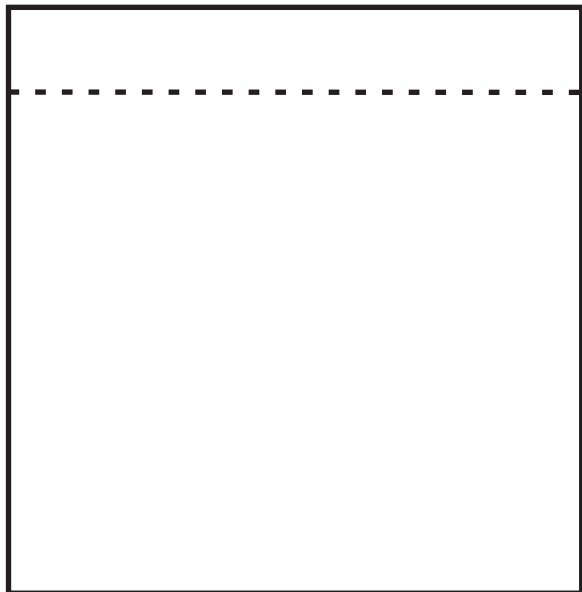
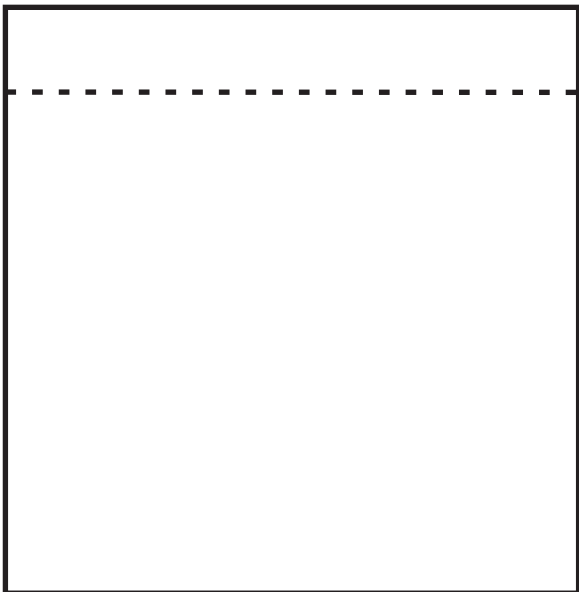
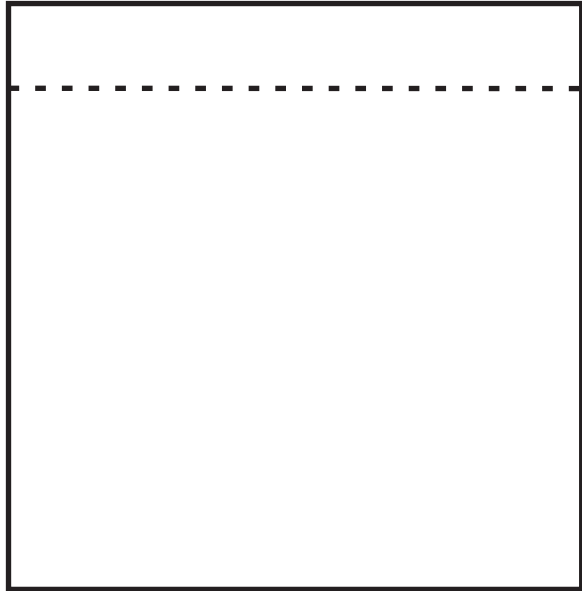
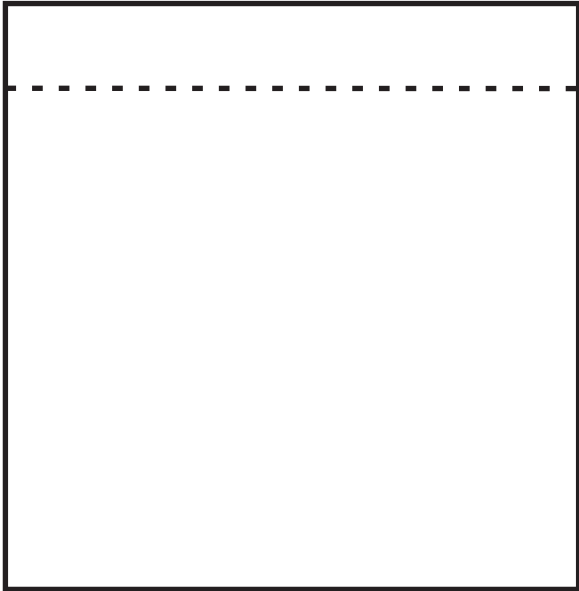
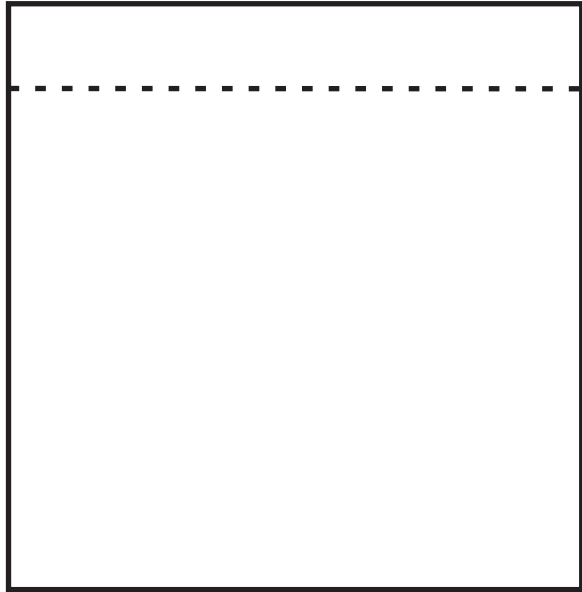
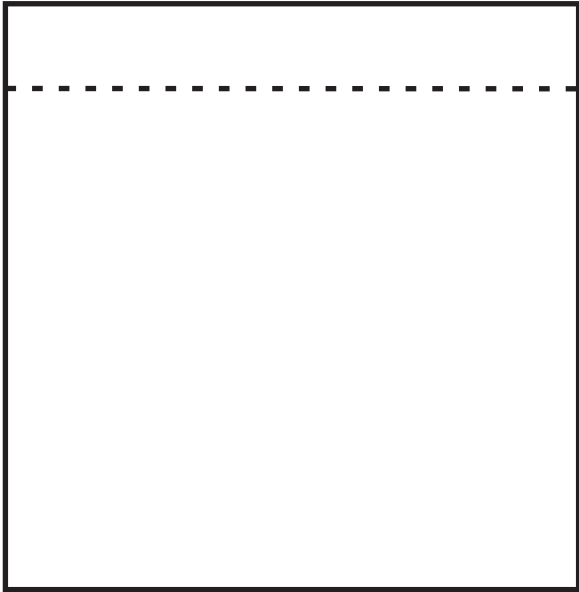

Name \_\_\_\_\_

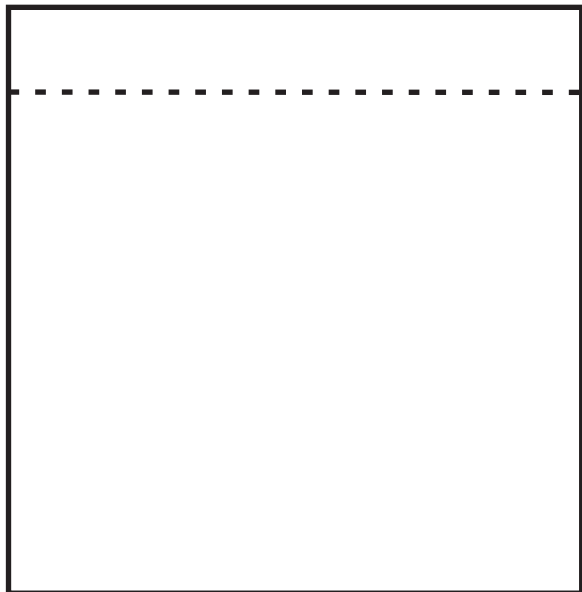
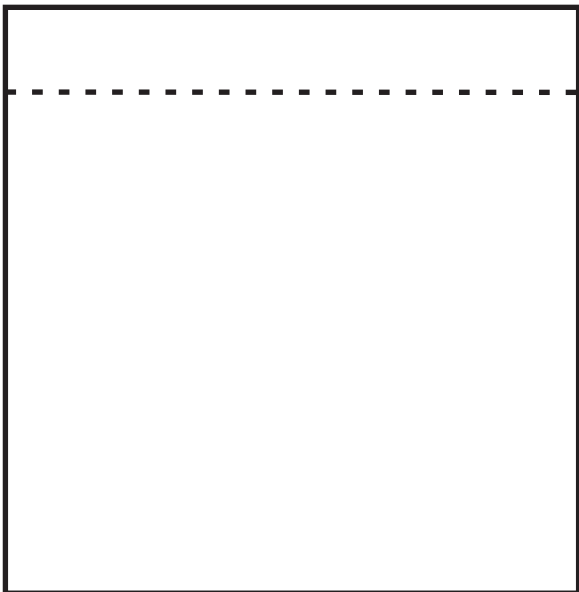
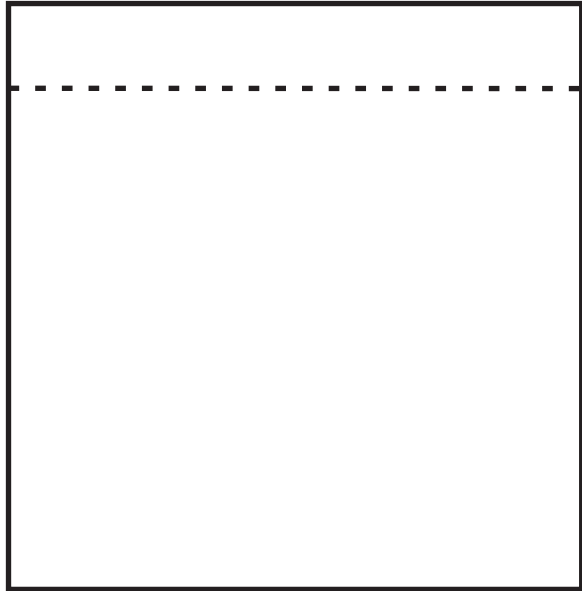
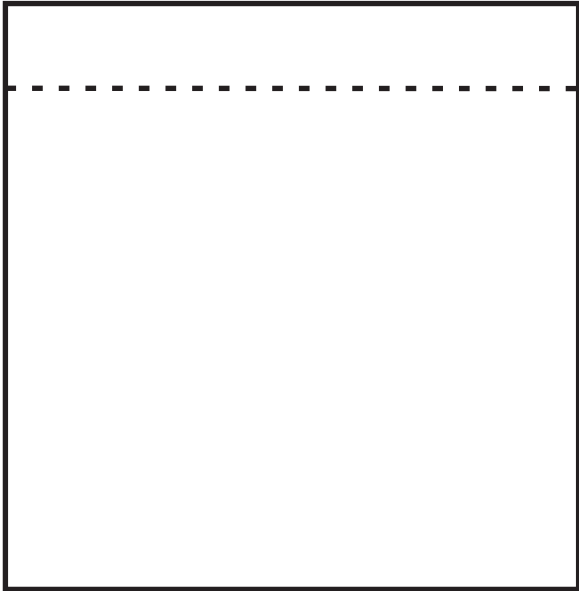
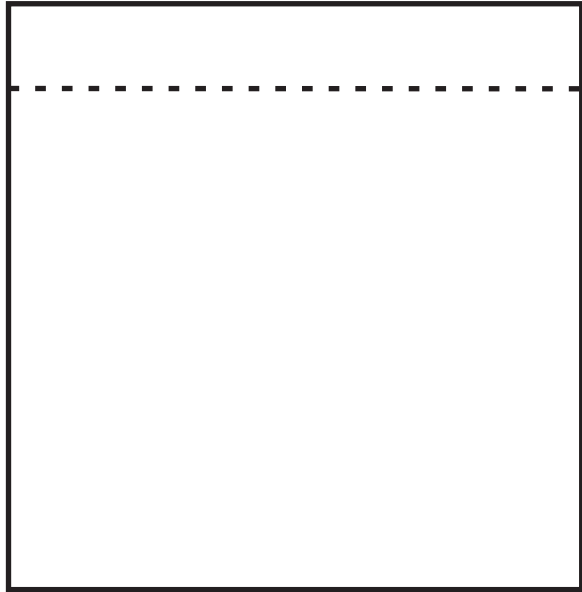
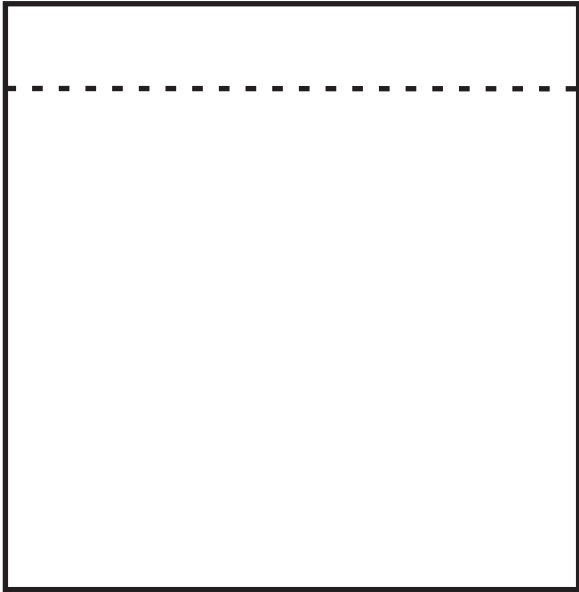

**“Fold Out Single Sounds”** is designed to develop and reinforce the recognition of single sounds in the beginning, middle and final positions within words.

- \* The students must trace the sound, write the sound in words and then paste the sound card over the picture that contains that sound. They can then fold the sound card back to reveal the picture underneath.
- \* The sound/picture cards are ideal to enlarge for class displays, or use for individual, group or class activities.
- \* The correct handwriting style for each state has been provided and can be used with the blank template to satisfy the requirements for each state in Australia.

This book is suitable for the following grades in different states.

	NSW	ACT	VIC	TAS	WA	NT	SA	QLD	NZ	
K, Prep	✓	✓	✓	✓						LOWER MIDDLE UPPER
1					✓	✓	✓	✓	✓	
2										
3										
4										
5										
6										
7										

**Burrabooks** publications are written by Australian teachers who have had extensive classroom experience.

For more information visit:

[www.burrabooks.com.au](http://www.burrabooks.com.au)

ISBN 192098214-0

