

# ADVANCED PHONICS

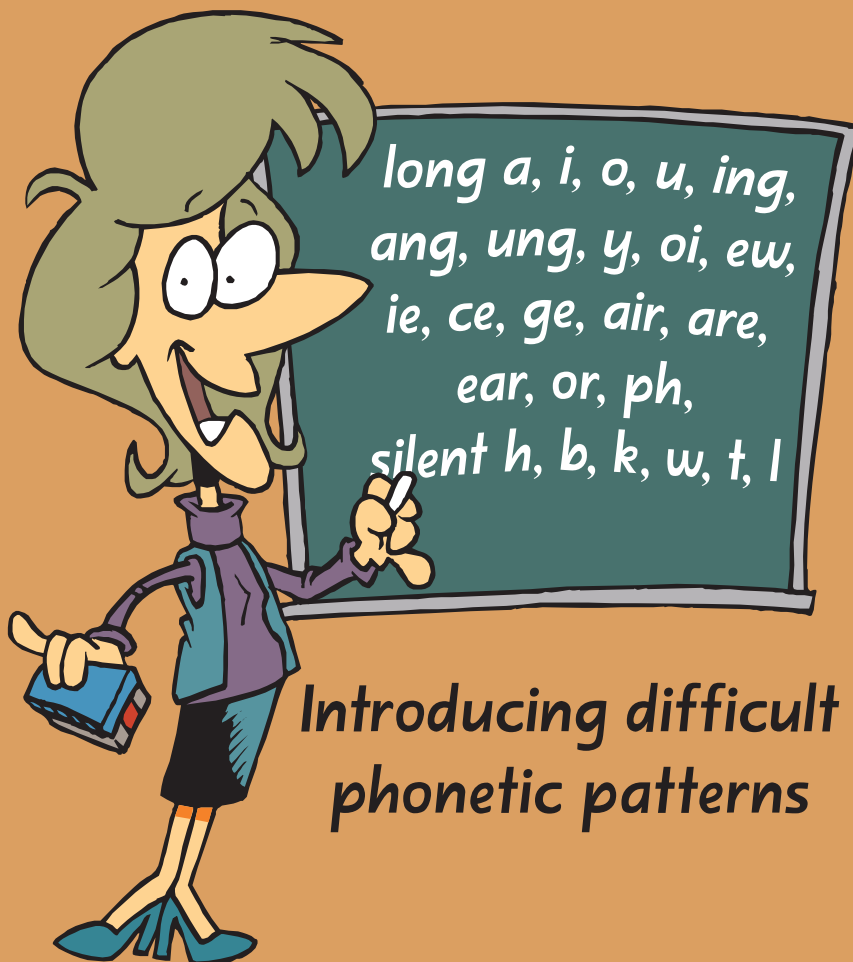

# ADVANCED PHONICS

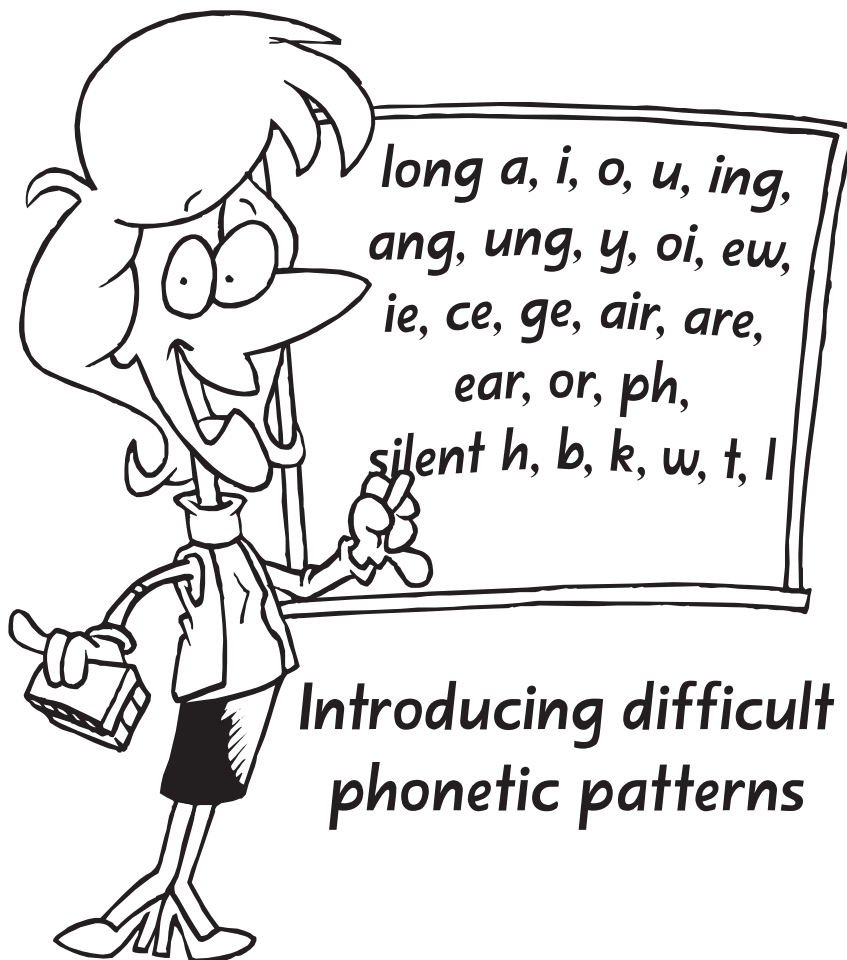

## **Advanced Phonics**

written by Louise and Greg Porich

© Burrabooks Pty Ltd.

First Published 2006

ABN 22 070 006 085

P. O. Box 611,

Moruya NSW 2537

Ph: 0244 742 355

Fax: 0244 742 399

[www.burrabooks.com.au](http://www.burrabooks.com.au)

All rights reserved.

### **COPYING FOR EDUCATIONAL PURPOSES**

The purchaser of this book is granted permission by the publisher to make copies of the pages within the book, beyond their rights under the Australian Copyright Act 1968 (the Act), provided that the number of copies made does not exceed the number reasonably required for use in one classroom only; that copies are only made by photocopying and are not copied, stored or transmitted by any electronic or digital means; copies are not sold or lent. Copying of this book outside this licence may fall within the educational statutory licence under the Act.

### **COPYING FOR OTHER PURPOSES**

Unless copying is specifically permitted by the educational statutory licence, the licence granted to the purchaser of this book or the fair dealing clause in the Act (for the purposes of study, research, criticism or review), no part of this book may be reproduced, stored in a retrieval system, transmitted in any form or by any means without prior written permission from the publisher.

Some images used with permission of Ron Leishman.

As with all Burrabooks publications every attempt is made to acknowledge copyright. Any infringements are purely coincidental and the publisher offers apologies where applicable.

ISBN 1 92098 221 3

**[www.burrabooks.com.au](http://www.burrabooks.com.au)**

**[mail@burrabooks.com.au](mailto:mail@burrabooks.com.au)**

**Latest books, news & more.**

**BUR-5026**



# CONTENTS

*Advanced Phonics* introduces more difficult phonetic patterns within words.

Page	Sound	Page	Sound
2, 3	long a	36, 37	air
4, 5	long o	38, 39	are
6, 7	long i	40, 41	Revision ce, ge, air, are
8, 9	long u	42, 43	ear
10, 11	Revision long a, o, i, u	44, 45	or
12, 13	ing	46, 47	ph
14, 15	ang	48, 49	ie (long e)
16, 17	ung	50, 51	Revision ear, or, ph, ie
18, 19	y (long e)	52, 53	silent h
20, 21	Revision ing, ang, ung, y	54, 55	silent b
22, 23	y (long i)	56, 57	silent k
24, 25	oi	58, 59	Revision silent h, b, k
26, 27	ew	60, 61	silent w
28, 29	ie	62, 63	silent t
30, 31	Revision y, oi, ew, ie	64, 65	silent l
32, 33	ce	66, 67	Revision silent w, t, l
34, 35	ge	68, 69, 70	Word lists

@ at the end of the word makes the vowel at the front say it's name

Name: \_\_\_\_\_

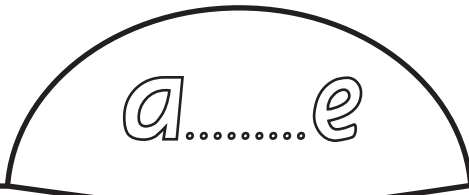

Write the missing letters. Join the word and the picture.

c...k.....

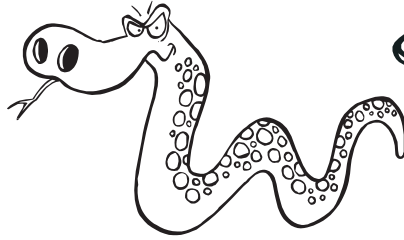

w...u.....

pl...t.....

sn...k.....



fl...m.....

g...t.....

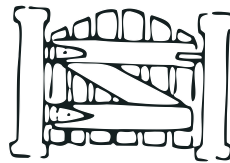

Write the long a words again.



.....



.....



.....



.....



.....



.....

Use long a words in the sentences.

date Dad ..... with me.

came We like to swim in the .....

tape I have lost my .....

lake What is the ..... today?



e at the end of the word makes the vowel at the front say it's name

Name: \_\_\_\_\_

Finish the crossword using these words.

a.....e

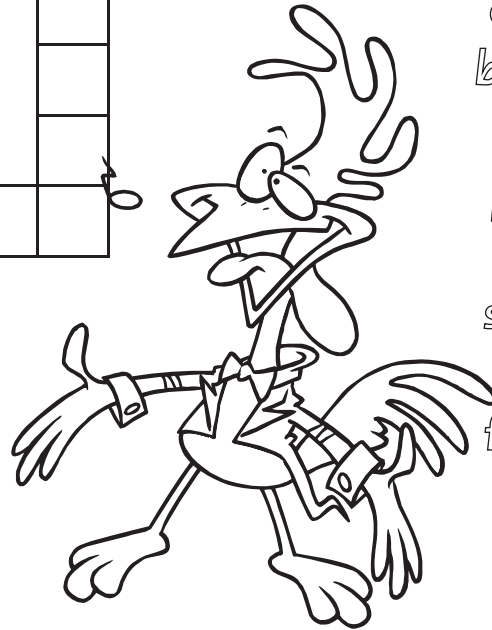
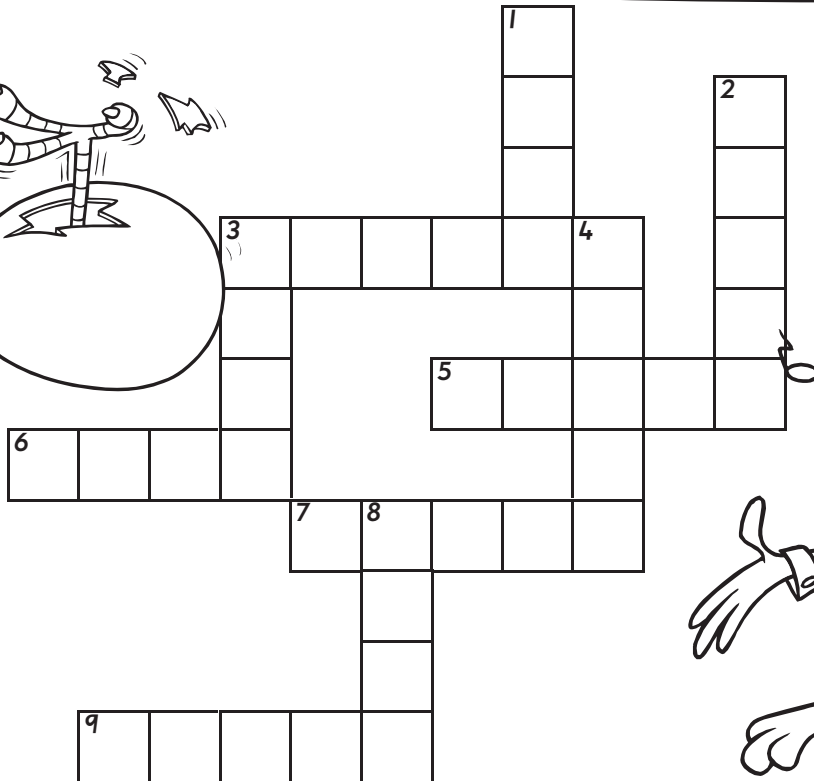
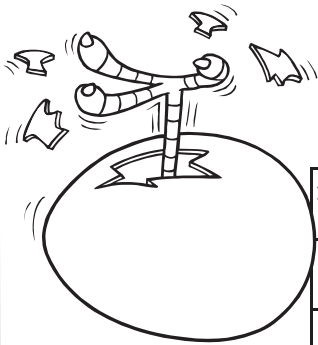

skate  
crate  
brakes  
rake  
plate  
lake  
shade  
cage  
flame  
bake

**ACROSS**

3. Cars stop with them.
5. You do this on the ice.
6. Some birds are kept in a \_\_\_\_\_.
7. The fire had a hot, red \_\_\_\_\_.
9. My dinner is on a \_\_\_\_\_.

**DOWN**

1. This is used on leaves.
2. A large box.
3. Mum will \_\_\_\_\_ a cake.
4. I sit in the \_\_\_\_\_ on a hot day.
8. You can swim in a \_\_\_\_\_.

Write the long a words under the pictures.

whale face snake cave wave trace

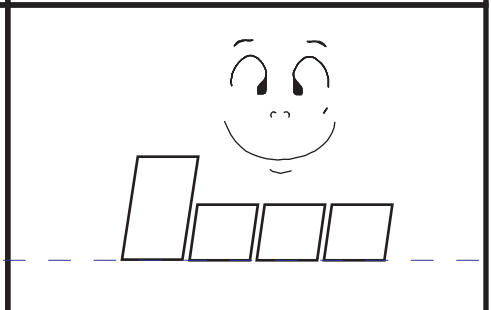
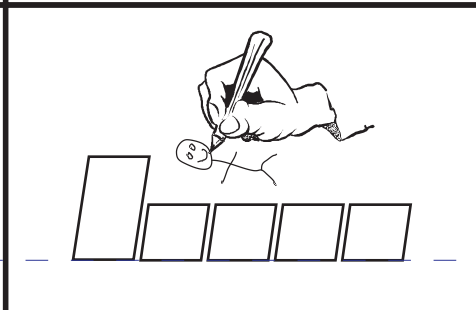
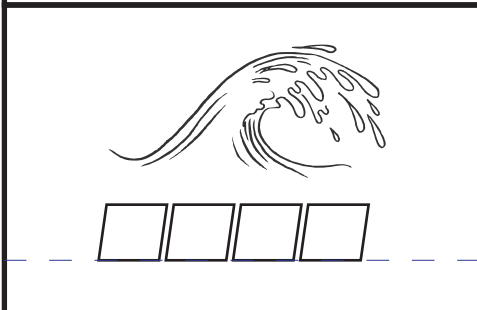
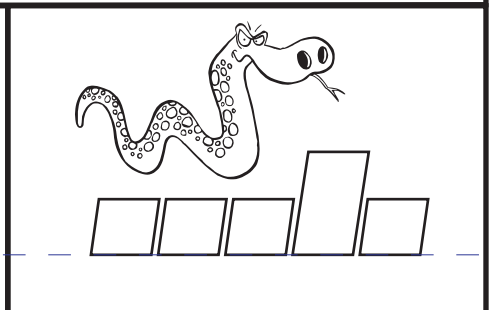
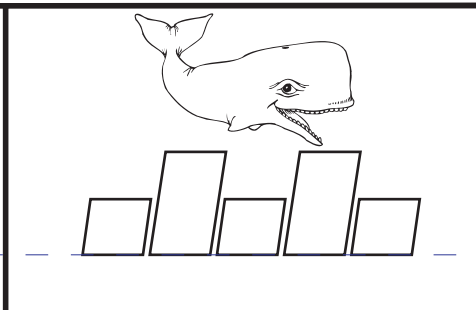
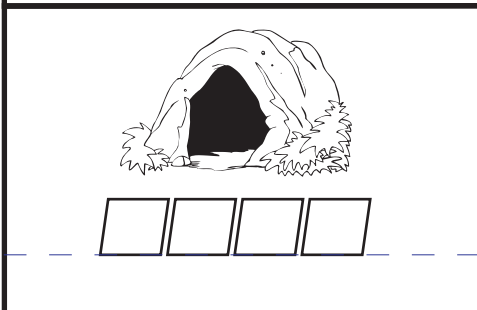

@ at the end of the word makes the vowel at the front say it's name

Name: \_\_\_\_\_

Find the long o words in the puzzle.

o.....e

j	e	y	m	p	x	d	b
p	t	k	t	h	o	s	e
g	o	b	o	m	m	k	s
u	n	l	e	l	o	p	o
c	e	d	q	r	b	r	p
l	o	w	b	e	o	a	x
c	a	n	l	p	f	b	m
b	i	x	e	r	u	j	e

- \*bloke
- \*those
- \*pose
- \*code
- \*cone
- \*broke
- \*pole
- \*rope
- \*dome
- \*robe
- \*hole
- \*note



Find the long o words from above and trace them.

those	broke	rope	note
see	cone	pose	you
dome	hole	bloke	can
code	pole	me	robe

Write a sentence using the words that are left.

.....

.....

e at the end of the word makes the vowel at the front say its name

Name: \_\_\_\_\_

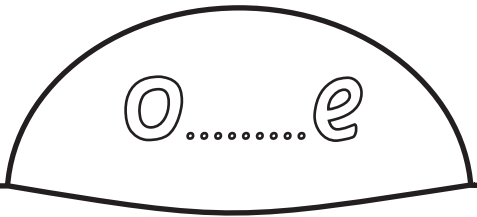

Unjumble the long o word to finish the sentences.

1. The dog chews the obne \_\_\_\_\_.
2. Dad okew \_\_\_\_\_ up at 7 o'clock.
3. Give me that etno \_\_\_\_\_.
4. I ohpe \_\_\_\_\_ he can come.
5. We had an ice-cream ocne \_\_\_\_\_.

Write 4 more long o words.

.....

.....

.....

.....

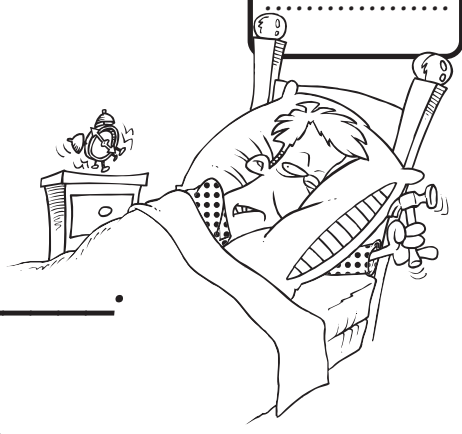

Write the correct sentence under the picture and finish it.



.....

.....

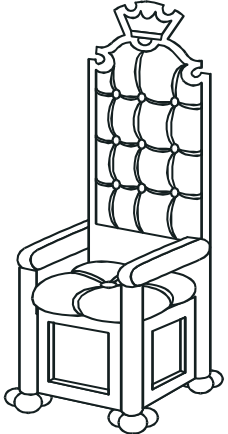

.....

.....

Smoke is coming out of the stove.

The queen is sitting on the throne.



@ at the end of the word makes the vowel at the front say it's name

Name: \_\_\_\_\_

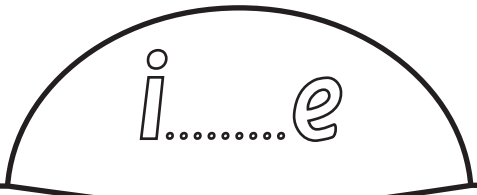

Write the missing letters. Join the word and the picture.

dr...u.....

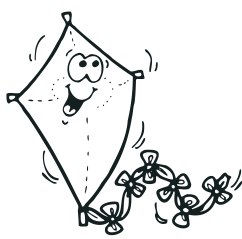

sm...l.....

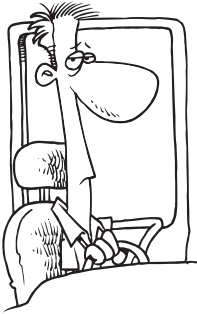

f...u.....



k...t.....

b...k.....



br...d.....



Write the long i words again.

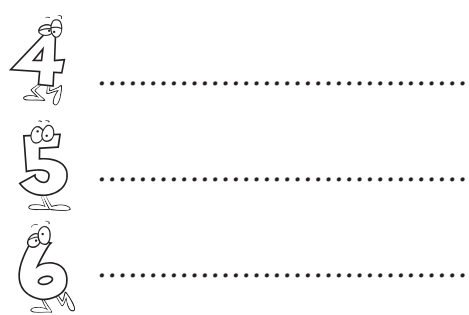
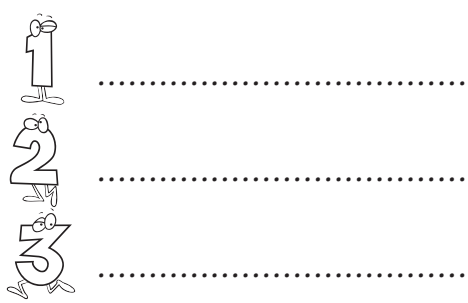

Use long i words in the sentences.

slide

Have a ..... of my apple.

prize

We all went down the .....

bite

My shirt has a ..... on the side.

stripe

He won first ..... in the contest.

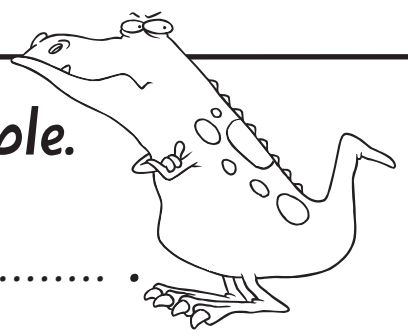

@ at the end of the word makes the vowel at the front say it's name

Name: \_\_\_\_\_

Finish the crossword using these words.

i.....e

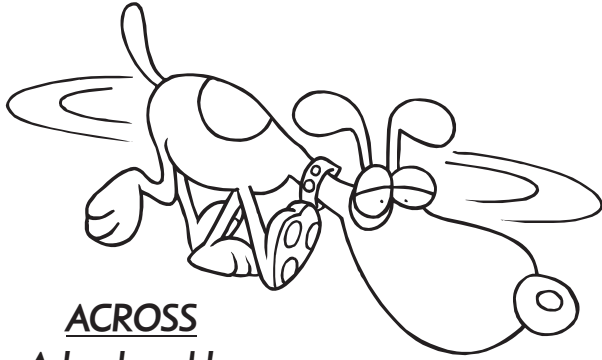

**ACROSS**

- 3. A husband has one.
- 4. This has a sharp end.
- 6. \_\_\_\_\_ can be very slippery.
- 9. A type of dance.
- 10. A bell can do this.

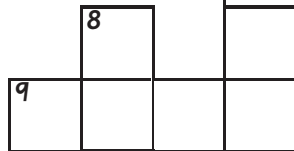
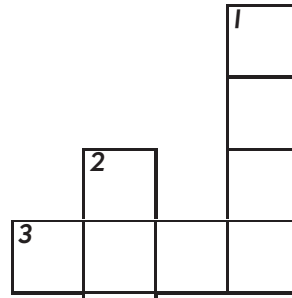

**DOWN**

- 1. \_\_\_\_\_ is very hot.
- 2. Grapes grow on this.
- 5. A type of tree.
- 7. A tiny insect.
- 8. People who break the law may get a \_\_\_\_\_.

- jive
- mite
- slime
- chime
- pine
- fine
- spike
- vine
- wife
- fire



Write the long i words under the pictures.

hive    nine    pipe    slide    twine    wire

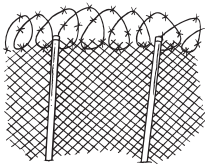

□ □ □ □



□ □ □ □



□ □ □ □



□ □ □ □ □



□ □ □ □ □



□ □ □ □

@ at the end of the word makes the vowel at the front say it's name

Name: \_\_\_\_\_

Find the long u words in the puzzle.

u.....e

q	c	e	t	u	l	f	j
y	u	z	x	c	q	h	u
a	t	d	u	c	r	f	w
s	e	m	u	f	u	j	o
d	b	s	n	k	l	s	u
b	u	h	u	g	e	t	e
q	t	n	o	f	u	c	l
c	u	r	e	t	u	m	d

- \*cute
- \*tube
- \*fume
- \*excuse
- \*duke
- \*fuse
- \*rule
- \*dune
- \*mute
- \*flute
- \*cure
- \*huge



Find the long u words from above and trace them.

rule	tube	work	cure
duke	fume	excuse	huge
best	cute	your	do
mute	flute	fuse	dune

Write a sentence using the words that are left.

.....

.....

@ at the end of the word makes the vowel at the front say it's name

Name: \_\_\_\_\_

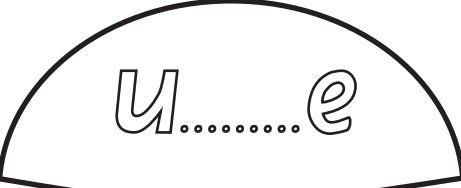

Unjumble the long u word to finish the sentences.

1. That baby is very *ucte* \_\_\_\_\_.

2. He plays the *uflet* \_\_\_\_\_ in the band.

3. She was very *rdue* \_\_\_\_\_ to me.

4. Do you know the *tnue* \_\_\_\_\_ of that song?

5. That shape is a *uceb* \_\_\_\_\_.

Write 4 more long u words.  
.....  
.....  
.....  
.....

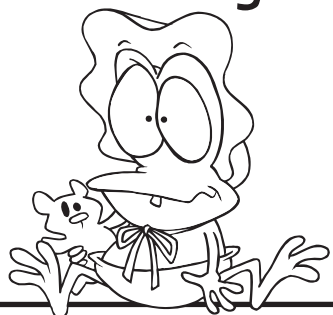

Write the correct sentence under the picture and finish it.

.....  
.....

.....  
.....

The doctor is trying to *cure* the sick girl.  
Mum likes to play the *flute* outside.

Name: \_\_\_\_\_

# REVISION

a....e  
o....e

i....e

u....e

Write the correct word under the pictures.

cake

stove

whale

bone

smile

flute

kite

cube

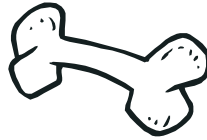
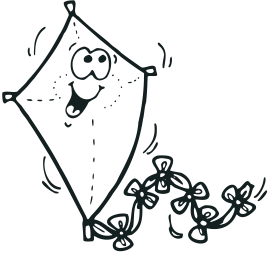

.....

.....

.....

.....

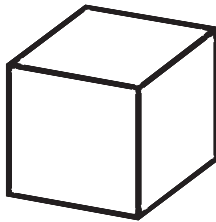
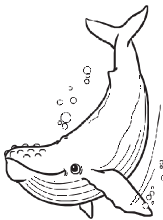

.....

.....

.....

.....

Write words that have the same sound.

gate

cone

bike

rude

.....

.....

.....

.....

.....

.....

.....

.....

.....

.....

.....

.....

Name: \_\_\_\_\_

# REVISION

a.....e  
o.....e

i.....e

u.....e

Write the word to finish the sentence.

1. I haven't got \_\_\_\_\_.

huge

2. That is a \_\_\_\_\_ box.

cave

3. He hid inside the \_\_\_\_\_.

rakes

4. What \_\_\_\_\_ do you need?

time

5. Dad \_\_\_\_\_ the leaves.

size

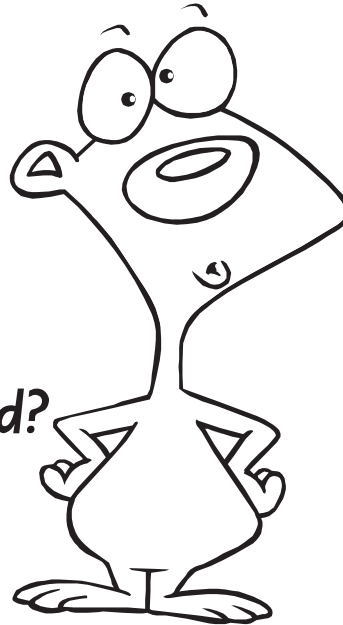

Write the sound to finish the words.



sn.....k.....



b.....k.....

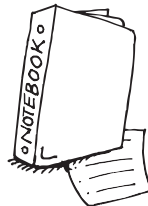

n.....t.....

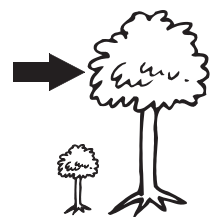

h.....g.....



t.....b.....



c.....n.....

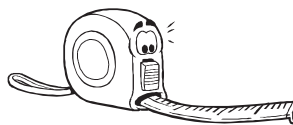

t.....p.....

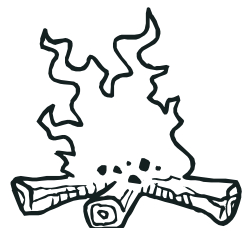

f.....r.....

Name: \_\_\_\_\_

.....ing

Write the missing letters. Join the word and the picture.

w .....



sw .....

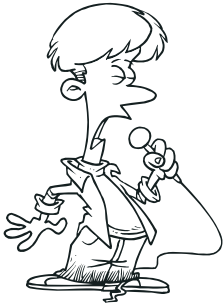

r .....



s .....

sl .....

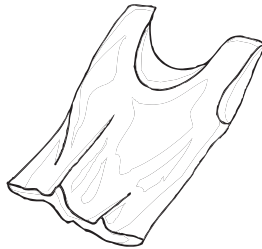

s.....let

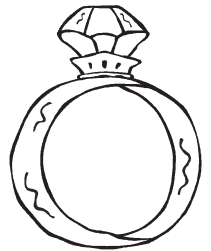

Write the ing words again and circle the ing sound.



.....  
.....  
.....



.....  
.....  
.....

Use ing words in the sentences.

bring

We all like to play ..... pong.

thing

Can you ..... your book here?

string

Use the ..... to tie it up.

ping

Which ..... do you mean?



Name: \_\_\_\_\_

.....ing

Finish the crossword using these words.

**ACROSS**

- 3. I went \_\_\_\_\_ in a boat.
- 4. A season for growing.
- 5. Tie the parcel with \_\_\_\_\_.
- 7. Hang the \_\_\_\_\_ on the clothesline.
- 8. Throw something.

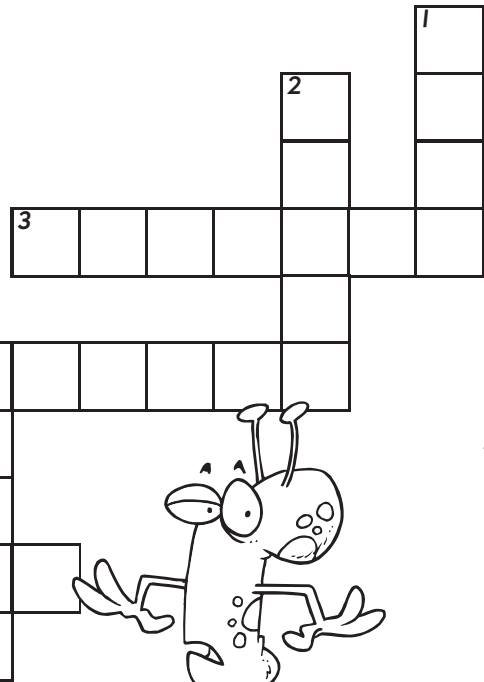

- sting
- spring
- wing
- fling
- sling
- string
- swing
- washing
- ring
- sailing

**DOWN**

- 1. All birds have two of these.
- 2. A bee can do this.
- 4. A broken arm needs one.
- 5. Found in a park.
- 6. Put a \_\_\_\_\_ on your finger.

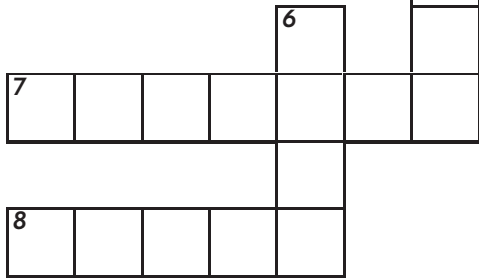

Write the *ing* words under the pictures.

swimming    raining    hopping    fishing    surfing    hugging

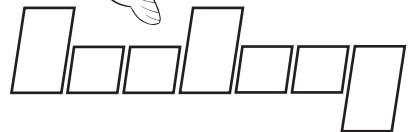
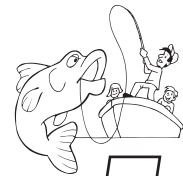
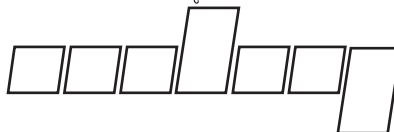
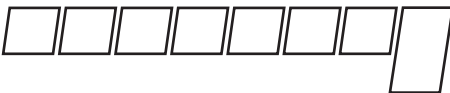



Name: \_\_\_\_\_

.....ang

Find the *ang* words in the puzzle.

y	e	g	p	a	g	j	c
s	g	n	a	r	n	l	e
b	a	n	g	h	a	n	g
k	j	n	a	n	p	n	e
m	g	s	g	t	a	a	g
o	n	n	p	l	q	q	c
i	a	y	s	m	l	s	o
f	g	n	a	r	p	s	r

- \*bang
- \*fang
- \*gang
- \*hang
- \*sang
- \*tang
- \*clang
- \*prang
- \*slang
- \*sprang
- \*pang
- \*rang

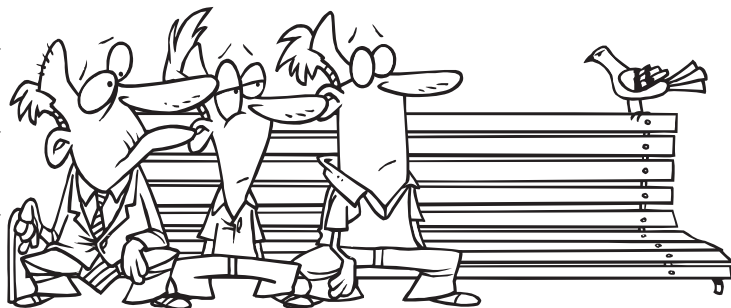

Find the *ang* words from above and trace them.

rang

sprang

what

tang

bang

pang

sang

slang

the

is

hang

gang

fang

clang

time

prang

Write a sentence using the words that are left.

Name: \_\_\_\_\_

.....ang

Unjumble the *ang* word to finish the sentences.

1. That tastes very *yatng* \_\_\_\_\_.
2. We all felt very *nygar* \_\_\_\_\_.
3. The rope is in a *eatngl* \_\_\_\_\_.
4. A person who fishes is an *renagl* \_\_\_\_\_.
5. We *nsga* \_\_\_\_\_ lots of songs.

Write 4 more  
*ang* words.

.....

.....

.....

.....



Write the correct sentence under the picture and finish it.



.....

.....

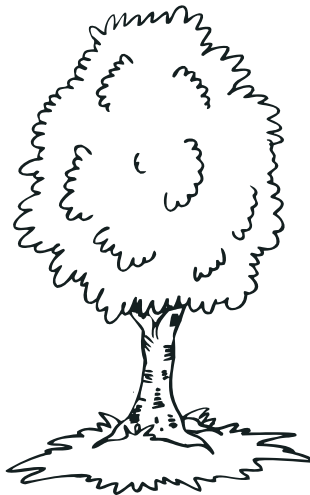

.....

.....

The *kangaroo* is beside the tree.  
The baby *bangs* on the drum.

Name: \_\_\_\_\_

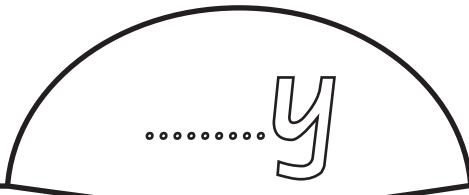

Write the missing letters. Join the word and the picture.

bod.....



empt.....



fift.....

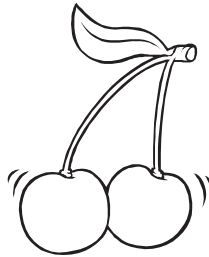

bab.....

cherr.....

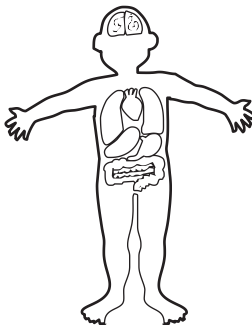

lad.....



Write the y words again and circle the y sound.



.....  
.....  
.....



.....  
.....  
.....

Use y words in the sentences.

party

I am ..... with you.

angry

The baby is .....

hungry

He is going to a .....

carry

Can you ..... that for me?

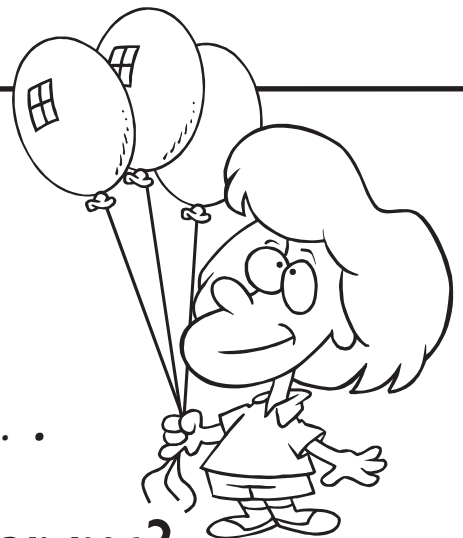

y at the end of the word says the long e sound

Name: \_\_\_\_\_

Finish the crossword using these words.

.....y



**DOWN**

1. A green and crunchy vegetable.
3. Five more than forty five.
6. A baby rabbit.
9. A very young person.

**ACROSS**

2. One more than nineteen.
4. Not clean.
5. Not full.
7. Needing a drink.
8. I will \_\_\_\_\_ there.
10. Very mad.

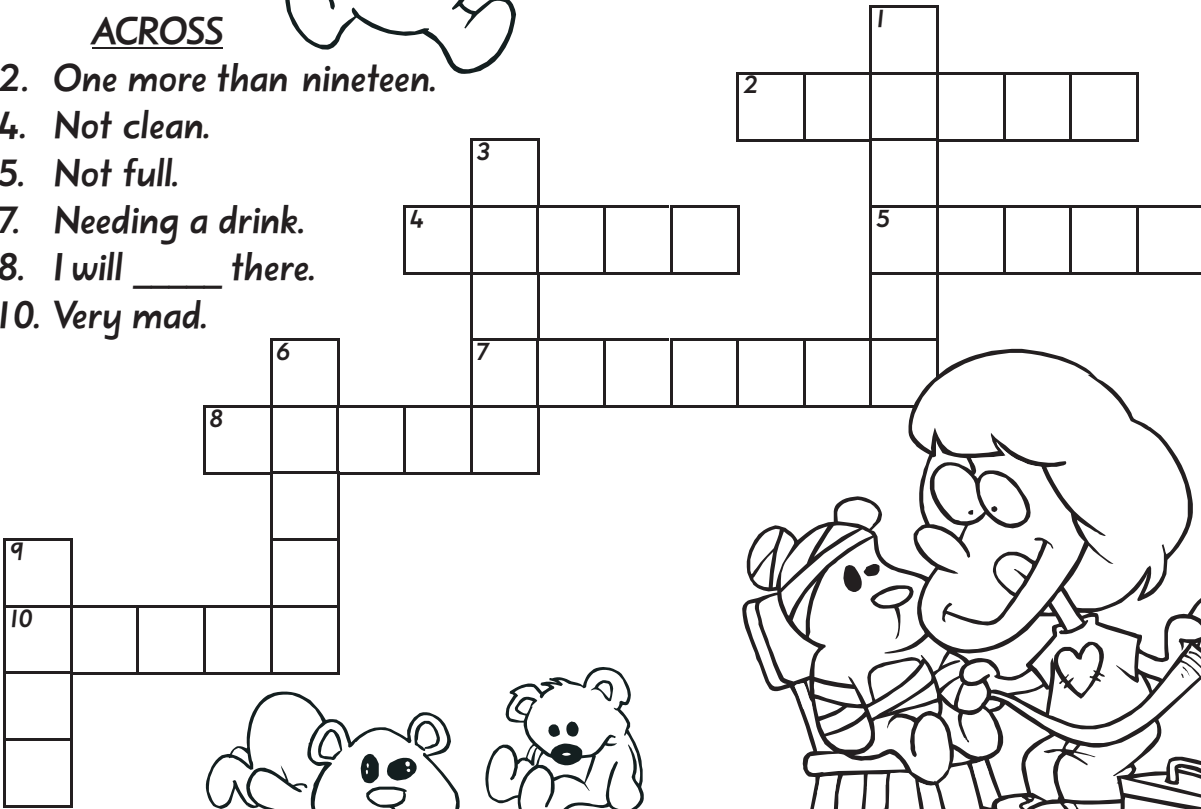

celery  
fifty  
hurry  
twenty  
dirty  
bunny  
angry  
empty  
baby  
thirsty

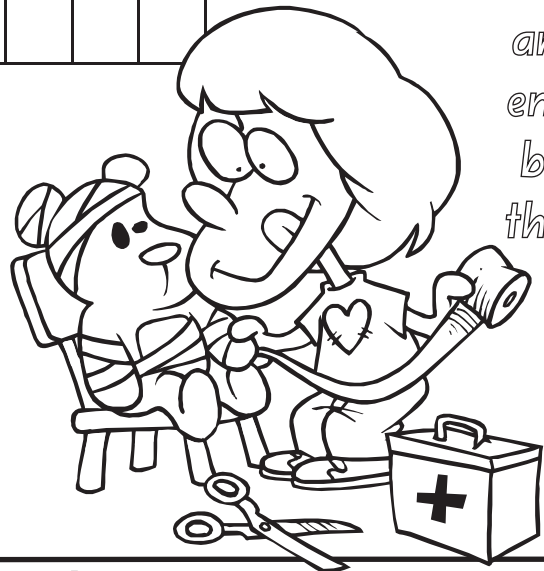

Write the y words under the pictures.

dirty    angry    bunny    celery    city    family

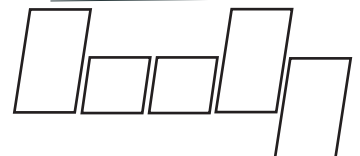
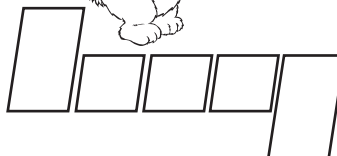
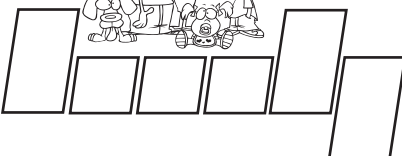
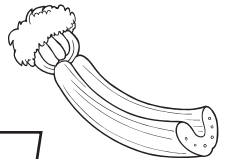
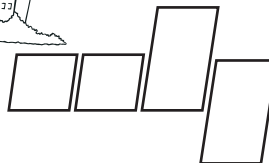
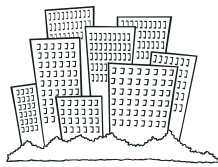

Name: \_\_\_\_\_

.....ung

Find the *ung* words in the puzzle.

e	e	c	g	n	u	w	s
l	u	k	l	m	e	j	t
g	s	p	r	u	n	g	u
n	t	f	l	u	n	g	n
u	r	b	r	u	n	g	g
b	u	q	l	h	u	n	g
t	n	s	o	z	u	u	r
g	g	r	f	s	o	l	f

- \*hung
- \*clung
- \*stung
- \*lung
- \*flung
- \*strung
- \*rung
- \*slung
- \*swung
- \*sung
- \*sprung
- \*bungle

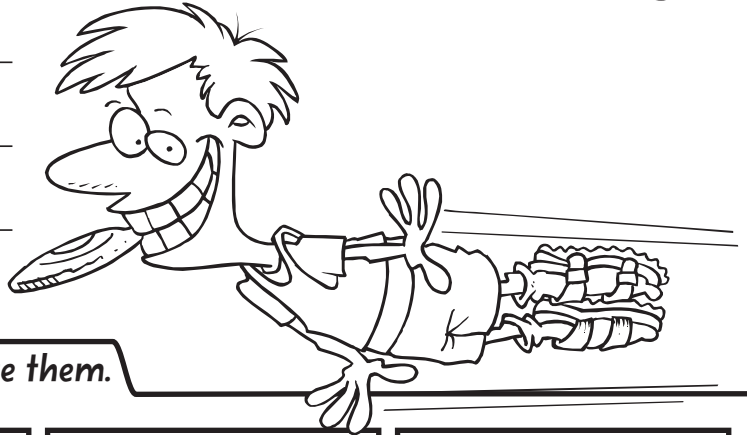

Find the *ung* words from above and trace them.

lung	strung	slung	what
swung	flung	doing	hung
bungle	you	sung	clung
rung	sprung	are	stung

Write a sentence using the words that are left.

.....

.....

Name: \_\_\_\_\_

.....ung

Unjumble the *ung* word to finish the sentences.

1. She *uhgn* \_\_\_\_\_ up the paintings.
2. Breathe air into your *lsgnu* \_\_\_\_\_.
3. They *lsgnu* \_\_\_\_\_ to their surfboards.
4. He was *tsnug* \_\_\_\_\_ by an insect.
5. Mum *gtsrun* \_\_\_\_\_ the lights up.

Write 4 more  
*ung* words.

.....

.....

.....

.....

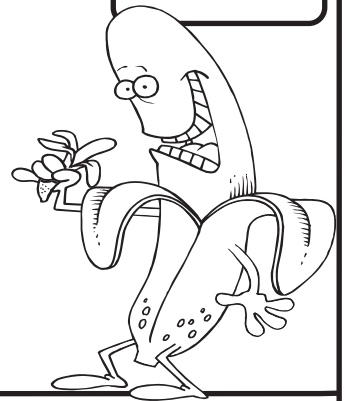

Write the correct sentence under the picture and finish it.

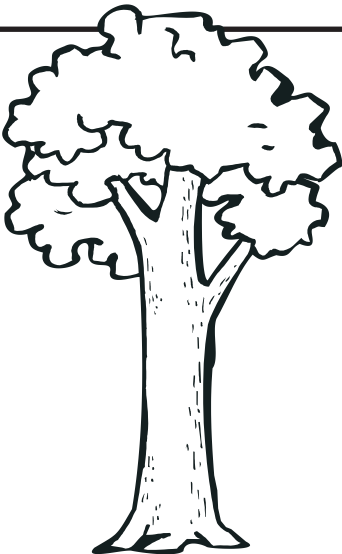

.....

.....



.....

.....

The boy *clung* to the tree.  
Dad was *stung* by a bee.

Name: \_\_\_\_\_

# REVISION

.....ing  
.....ung  
.....ang  
.....y

Write the correct word under the pictures.

tangle	ring	rang	lung
bunny	wing	sung	empty

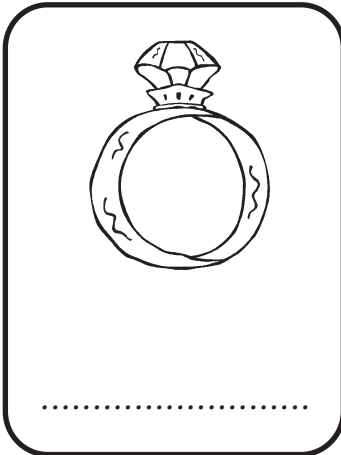
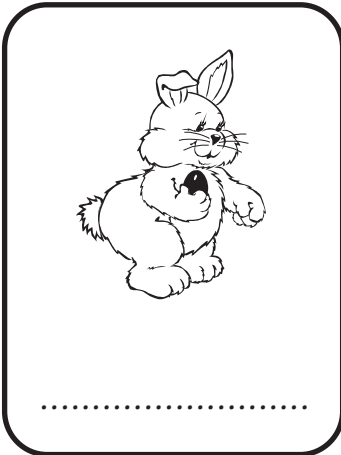
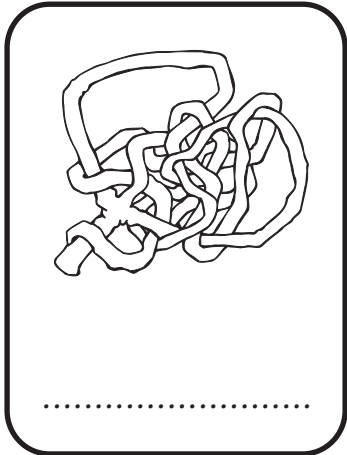
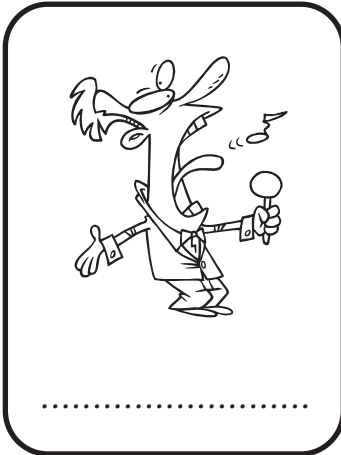
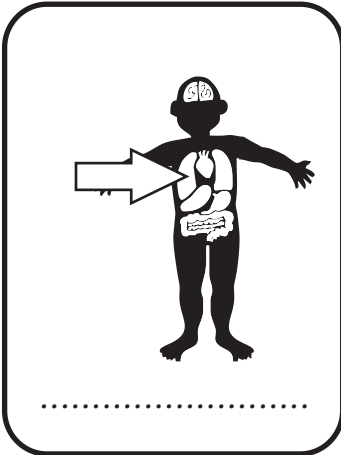

Write words that have the same sound.

sing

.....

.....

.....

gang

.....

.....

.....

lung

.....

.....

.....

hurry

.....

.....

.....

Name: \_\_\_\_\_

# REVISION

.....ing  
.....ung  
.....ang  
.....y

Write the word to finish the sentence.

- Dad pushes me on the \_\_\_\_\_ . sailing
- Mum \_\_\_\_\_ to talk to me. swung
- The branch \_\_\_\_\_ in the wind. dirty
- We went \_\_\_\_\_ on the lake. rang
- They were all very \_\_\_\_\_ . swing



Write the sound to finish the words.



sw.....



st.....



f.....



bab.....



k.....aroo

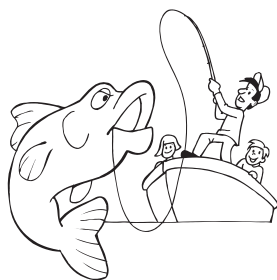

fish.....



angr.....



cl.....



y at the end of the word says the long i sound

Name: \_\_\_\_\_

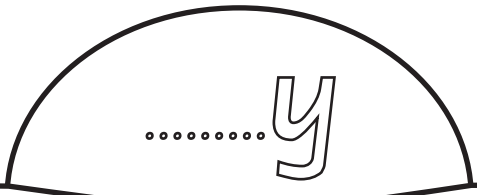

Write the missing letters. Join the word and the picture.

fl.....

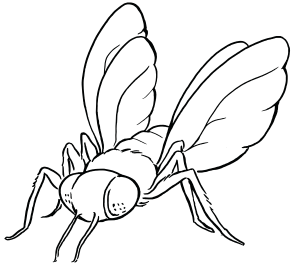

sp.....



sk.....



fr.....



butterfl.....

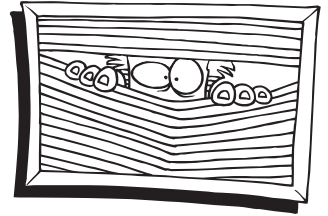

cr.....

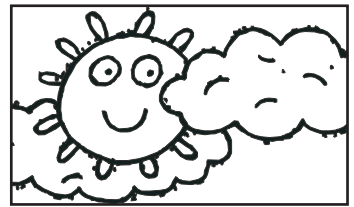

Write the y words again and circle the y sound.



.....  
.....  
.....



.....  
.....  
.....

Use y words in the sentences.

dry

Next month will be .....

try

Can you ..... my new shirt?

July

I always ..... my best.

by

She can do that ..... herself.



y at the end of the word says the long i sound

Name: \_\_\_\_\_

Finish the crossword using these words.

.....y

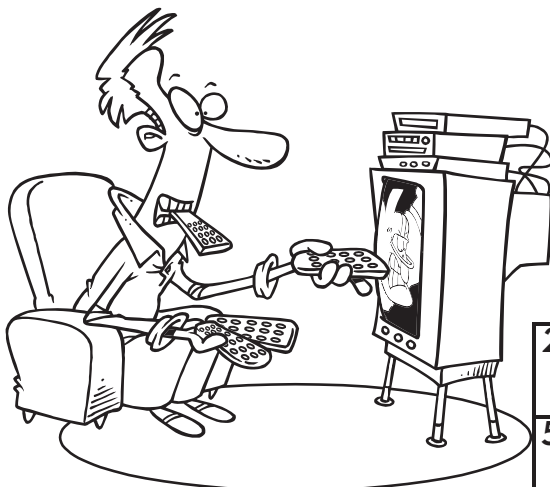

**ACROSS**

4. You can \_\_\_\_\_ your food.
5. I will \_\_\_\_\_ hard at school.
6. Some people are very \_\_\_\_\_.
7. When I am sad, I \_\_\_\_\_.
8. Opposite to wet.

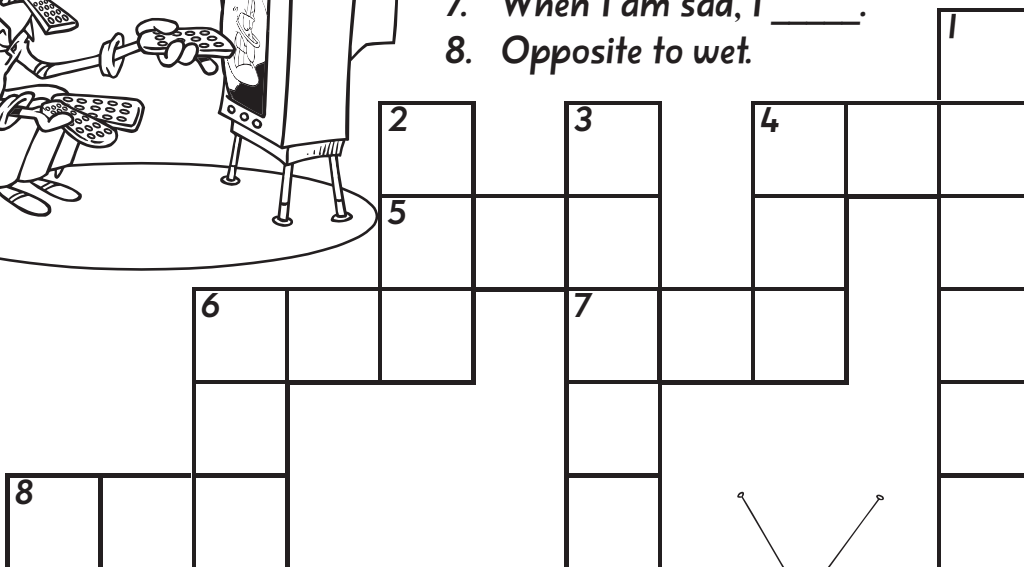

- dry
- sty
- cry
- fly
- fry
- python
- shy
- sky
- cycle
- try

**DOWN**

1. A type of snake.
2. Pigs live in a \_\_\_\_\_.
3. You do this on a bike.
4. Planes \_\_\_\_\_ in the sky.
6. The \_\_\_\_\_ is filled with clouds.

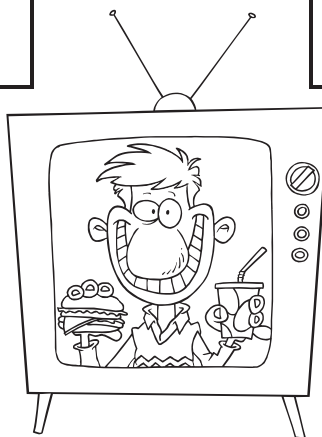

Write the y words under the pictures.

lychee    python    dry    cyclist    spy    unicycle

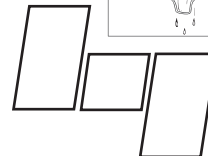
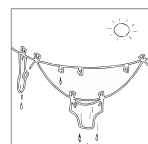
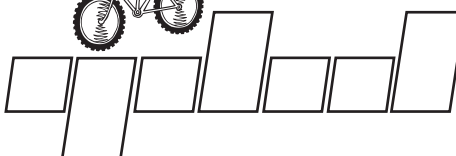
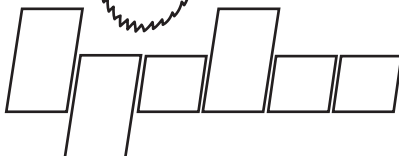
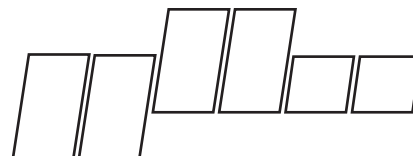
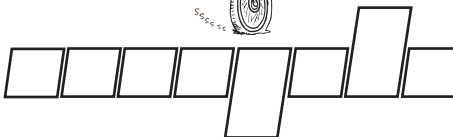
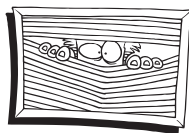

Name: \_\_\_\_\_

oi

Find the oi words in the puzzle.

l	p	k	t	g	a	e	t
l	i	o	p	s	o	i	l
m	h	o	l	f	o	i	l
o	o	j	t	z	o	t	i
i	i	w	o	n	n	z	o
s	s	e	s	i	o	n	b
t	t	b	o	o	n	i	e
c	t	p	r	c	j	f	n

- \*boil
- \*join
- \*spoil
- \*coin
- \*point
- \*moist
- \*foil
- \*soil
- \*toil
- \*oil
- \*noise
- \*hoist

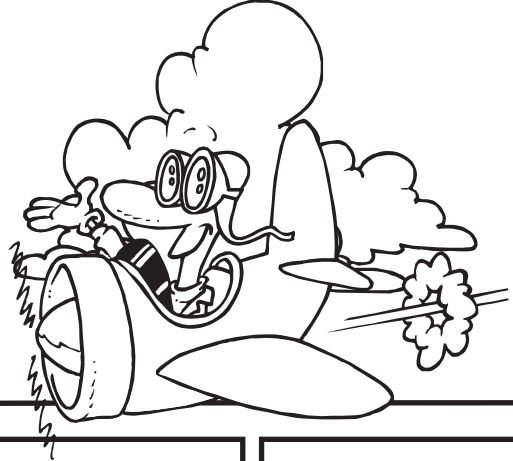

Find the oi words from above and trace them.

smile

oil

toil

boil

foil

me

soil

at

now

join

hoist

spoil

coin

noise

moist

point

Write a sentence using the words that are left.

.....

.....

Name: \_\_\_\_\_

oi

Unjumble the oi word to finish the sentences.

1. You have to bring a gold *ocin* \_\_\_\_\_ .
2. Can you *ntiop* \_\_\_\_\_ which way to go?
3. My hands feel *otims* \_\_\_\_\_ .
4. Will you *jnio* \_\_\_\_\_ the ends together?
5. Dad is going to put *iol* \_\_\_\_\_ in the car.

Write 4 more  
oi words.

.....

.....

.....

.....



Write the correct sentence under the picture and finish it.

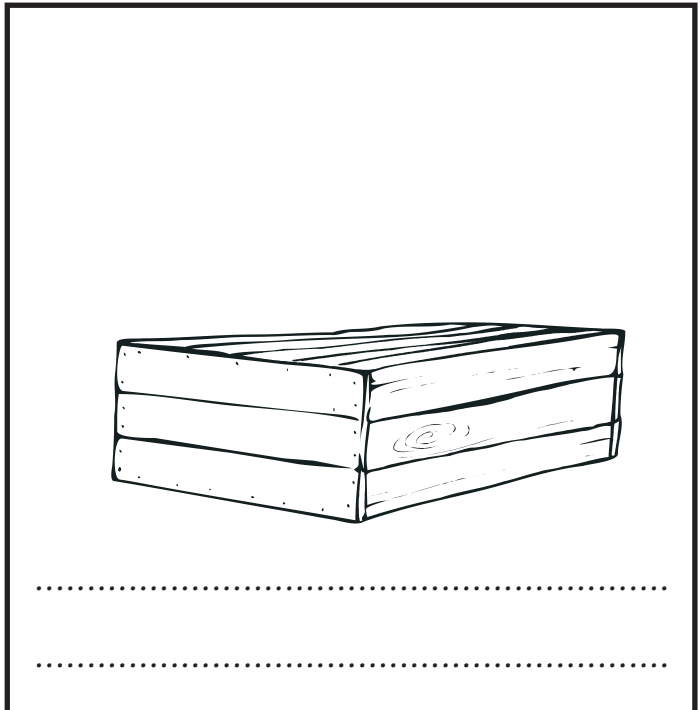
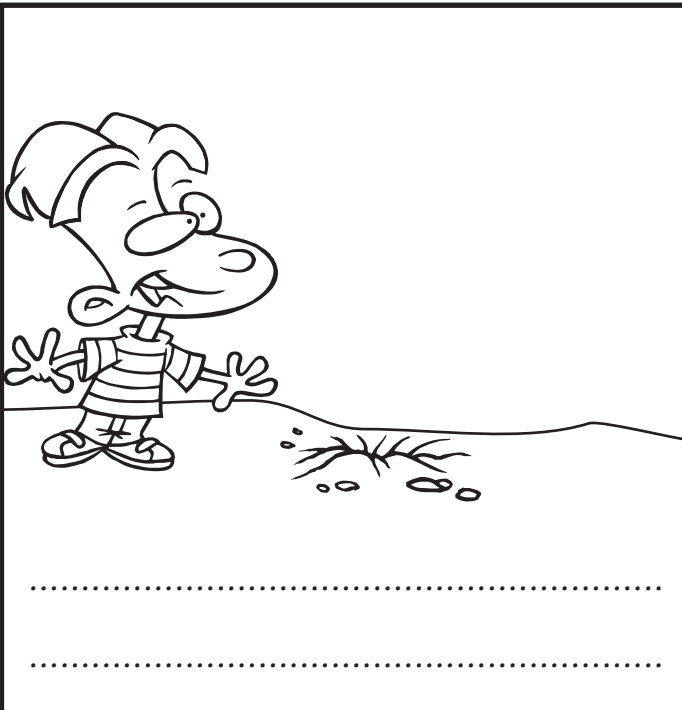

A **co**il of rope on a **bo**x.  
The boy is digging in the **so**il.

Name: \_\_\_\_\_

ew

Write the missing letters. Join the word and the picture.

scr.....

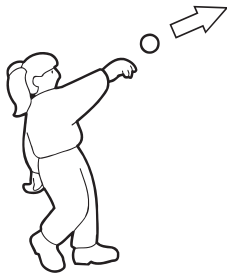

j.....el



ch.....

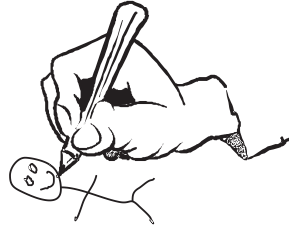

thr.....

dr.....

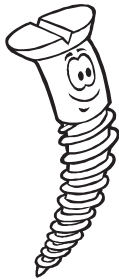

bl.....



Write the ew words again and circle the ew sound.



.....



.....



.....



.....



.....



.....

Use ew words in the sentences.

dew

She ..... that in her garden.

new

There are only a ..... left.

grew

Where are my ..... socks.

few

The ..... is on the grass.



Name: \_\_\_\_\_

ew

Finish the crossword using these words.

**ACROSS**

2. People who work on a ship.
4. Long and sharp.
7. A female sheep.
8. Not old, but \_\_\_\_.
9. The opposite to many.

- |       |        |
|-------|--------|
| chew  | skewer |
| few   | stew   |
| dew   | ewe    |
| pew   | new    |
| renew | crew   |

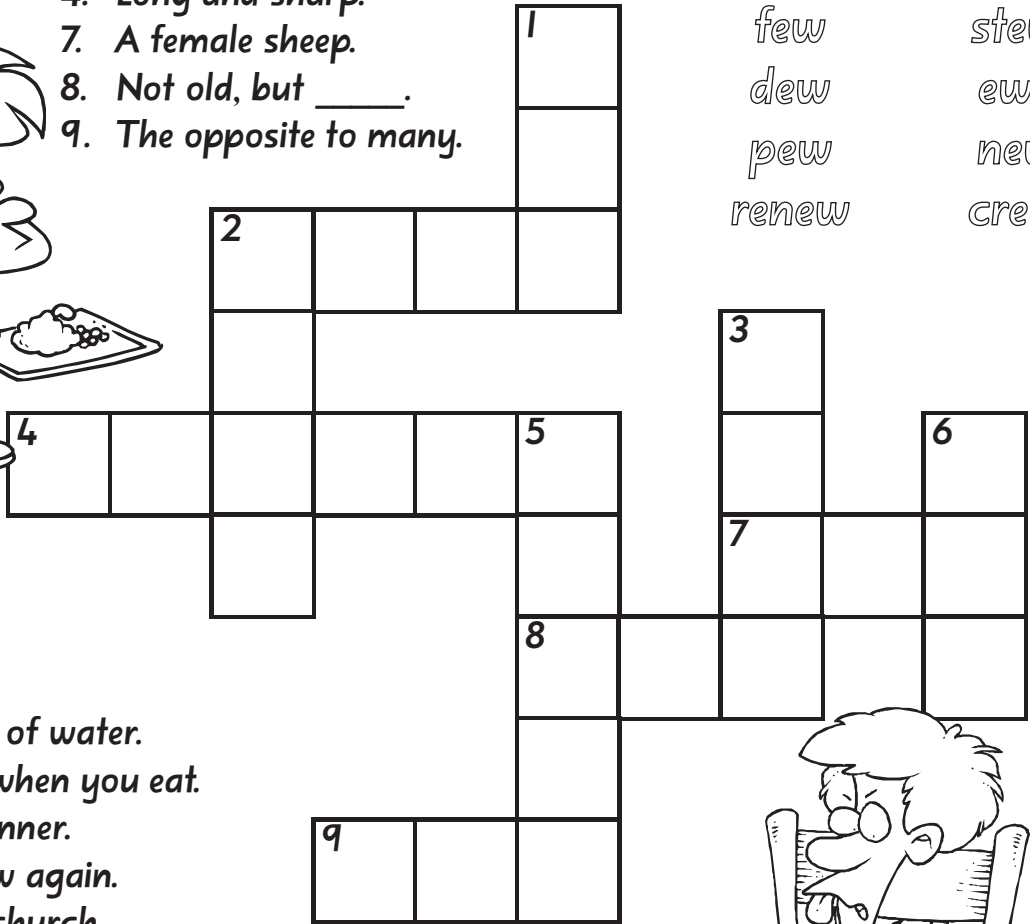



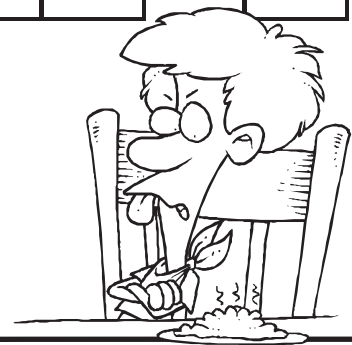

**DOWN**

1. Small drops of water.
2. You do this when you eat.
3. A type of dinner.
5. To make new again.
6. A seat in a church.

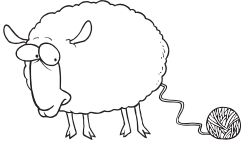

Write the *ew* words under the pictures.

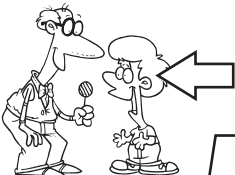
nephew    newspaper    ewe    blew    skewer    stew

 <div style="border: 1px solid black; width: 100px; height: 30px; margin: 5px auto;"></div>	 <div style="border: 1px solid black; width: 150px; height: 50px; margin: 5px auto;"></div>	 <div style="border: 1px solid black; width: 250px; height: 40px; margin: 5px auto;"></div>
 <div style="border: 1px solid black; width: 200px; height: 60px; margin: 5px auto;"></div>	 <div style="border: 1px solid black; width: 150px; height: 50px; margin: 5px auto;"></div>	 <div style="border: 1px solid black; width: 300px; height: 40px; margin: 5px auto;"></div>

Name: \_\_\_\_\_

ie

Find the ie words in the puzzle.

m	a	w	n	y	s	e	e
p	t	t	s	e	i	i	i
i	i	d	i	s	d	t	p
e	i	l	e	u	e	n	g
i	f	i	r	i	i	u	a
d	p	s	e	i	r	c	m
s	e	i	r	f	f	t	u
p	n	j	h	r	f	p	u

\*die

\*fries

\*flies

\*lie

\*spies

\*fried

\*pie

\*tried

\*untie

\*tie

\*cries

\*magpie

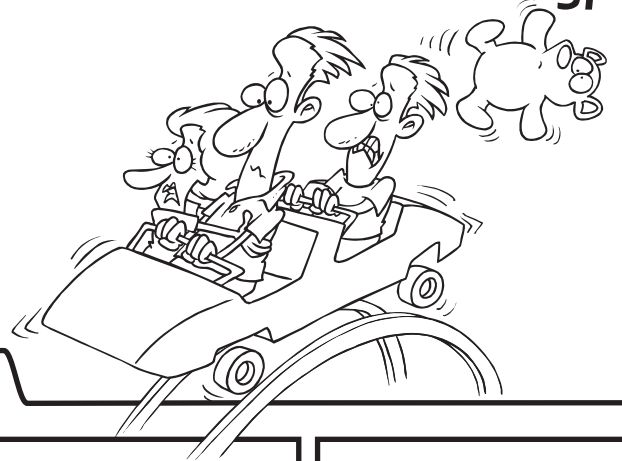

Find the ie words from above and trace them.

tie

pie

fries

lie

before

cries

die

think

magpie

flies

fried

you

spies

tried

speak

untie

Write a sentence using the words that are left.

.....  
.....

Name: \_\_\_\_\_

ie

Unjumble the *ie* word to finish the sentences.

1. Can you *iet* \_\_\_\_\_ the string?
2. She *lesi* \_\_\_\_\_ all the time.
3. His pet dog *eddi* \_\_\_\_\_.
4. They *deips* \_\_\_\_\_ on us.
5. Dad loves to eat *refid* \_\_\_\_\_ eggs.

Write 4 more  
*ie* words.

.....  
.....  
.....  
.....

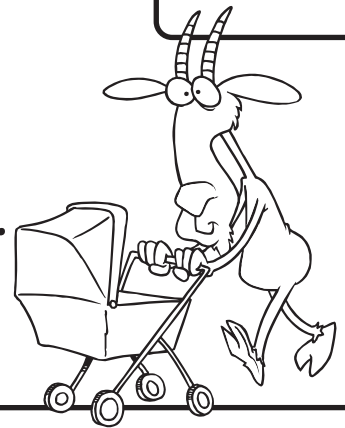

Write the correct sentence under the picture and finish it.

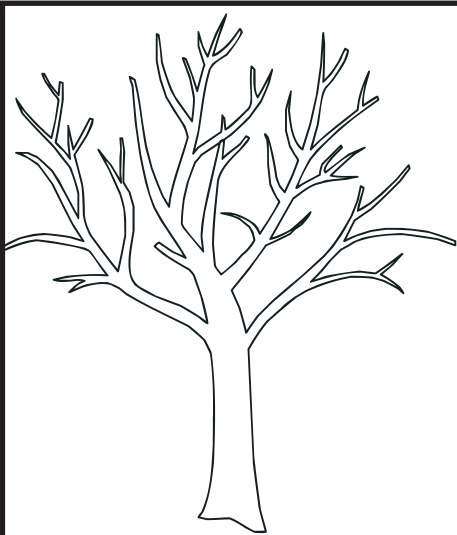

.....  
.....



.....  
.....

The *magpie* is on the branch.  
Dad *fried* the eggs.



Name: \_\_\_\_\_

# REVISION

ew oi .....y  
ie

Write the correct word under the pictures.

<b>boil</b>	<b>screw</b>	<b>cry</b>	<b>coins</b>
<b>jewel</b>	<b>tie</b>	<b>fry</b>	<b>pie</b>

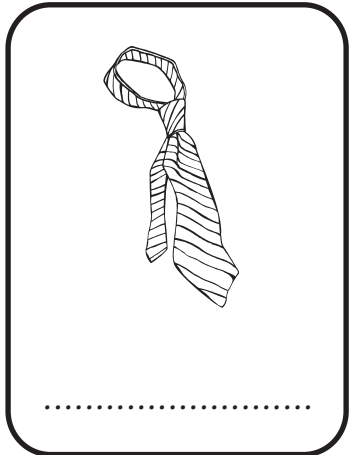
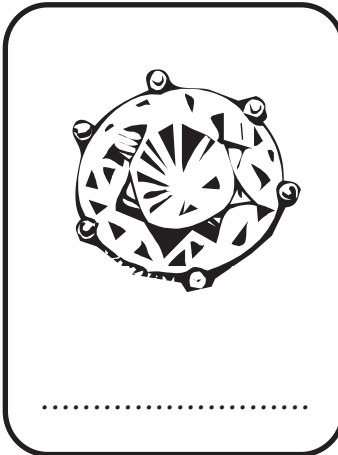
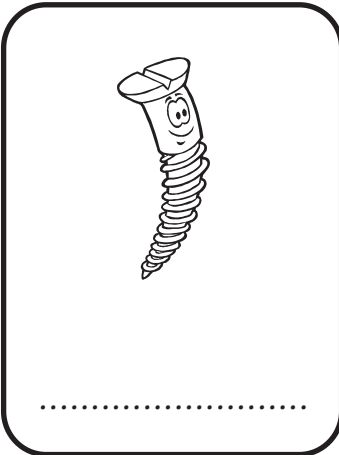
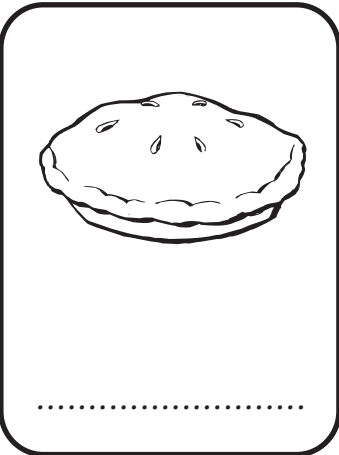
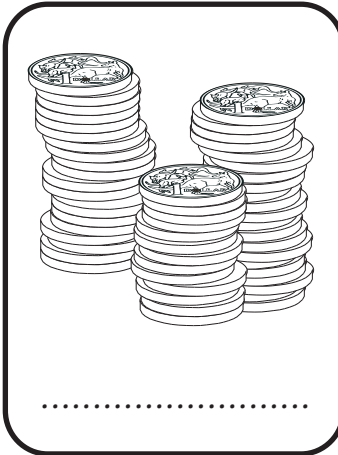
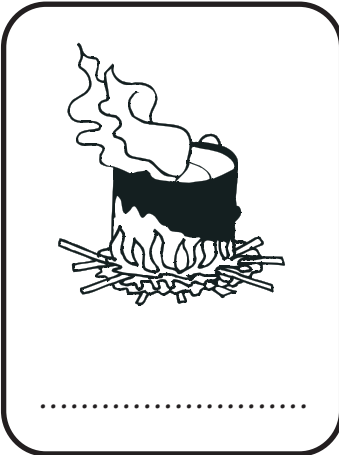

Write words that have the same sound.

**fly**

.....

.....

.....

**boil**

.....

.....

.....

**drew**

.....

.....

.....

**lie**

.....

.....

.....

Name: \_\_\_\_\_

# REVISION

ew oi .....y  
ie

Write the word to finish the sentence.

1. My friend is very \_\_\_\_\_ . new
2. Can you \_\_\_\_\_ that together? fry
3. Look at my \_\_\_\_\_ pencils. tried
4. She \_\_\_\_\_ hard not to cry. shy
5. Dad is going to \_\_\_\_\_ the eggs. join



Write the sound to finish the words.

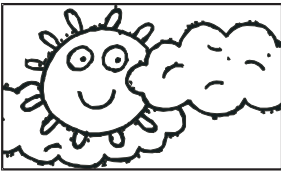

sk.....



ch.....

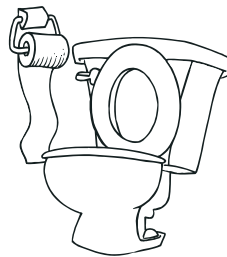

t.....let

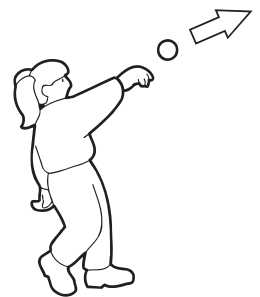

thr.....



magp.....



c.....l



p.....thon

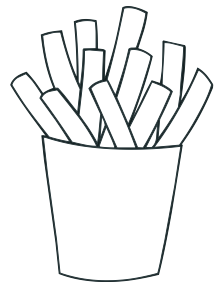

fr.....s

Name: \_\_\_\_\_

.....ce

Write the missing letters. Join the word and the picture.

dan.....

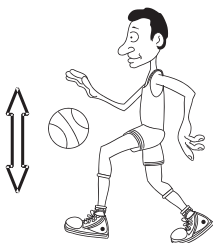

mi.....



ri.....



boun.....

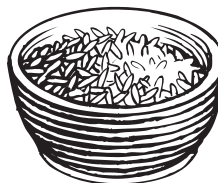

prin.....



fa.....



Write the ce words again and circle the ce sound.



.....



.....



.....



.....



.....



.....

Use ce words in the sentences.

chance He is speaking in a loud .....

place Can you give me another ..... ?

voice She is a ..... person.



nice We are going over to her .....

Name: \_\_\_\_\_

Finish the crossword using these words.

.....ce

**ACROSS**

- 5. A \_\_\_\_\_ goes around a house.
- 6. The queen lives in a \_\_\_\_\_.
- 7. No noise.
- 9. You play this game with a \_\_\_\_\_.
- 10. To look quickly.

- palace
- dice
- fleece
- space
- silence
- bounce
- glance
- ice
- braces
- fence

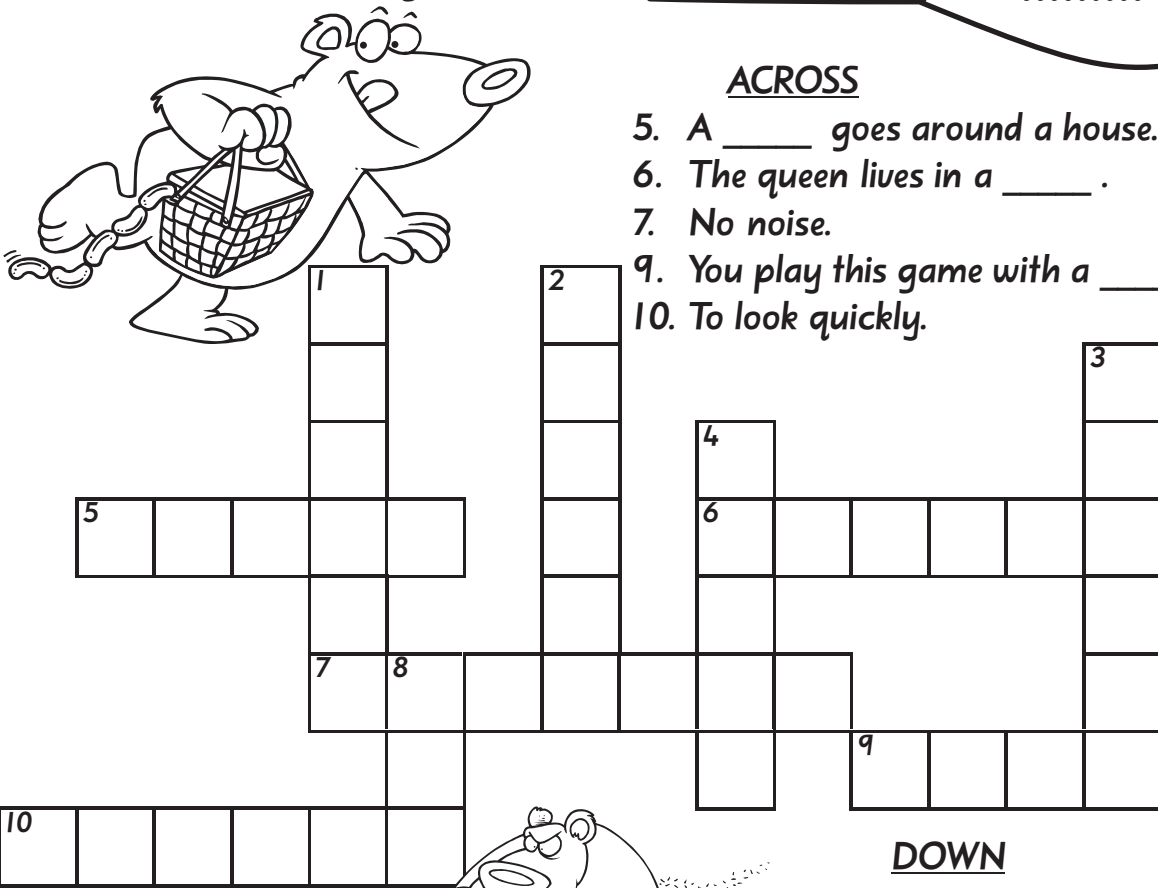

**DOWN**

- 1. You need \_\_\_\_\_ on your teeth.
- 2. Balls \_\_\_\_\_ up and down.
- 3. A sheep's covering is a \_\_\_\_\_.
- 4. The rocket went into \_\_\_\_\_.
- 8. Frozen water.

Write the ce words under the pictures.

police    sauce    race    fence    dice    necklace

<p>_____</p>	<p>_____</p>	<p>_____</p>
<p>_____</p>	<p>_____</p>	<p>_____</p>

g followed by e says the sound of the letter j

Name: \_\_\_\_\_



Find the ge words in the puzzle.

e	c	h	a	n	g	e	f
g	e	h	i	n	g	e	r
n	g	x	m	r	d	l	i
a	n	e	o	p	j	l	n
r	i	g	g	w	a	q	g
t	w	z	u	r	y	g	e
s	t	a	g	e	a	x	e
a	g	e	g	a	c	b	f

- \*age
- \*stage
- \*change
- \*cage
- \*fringe
- \*twinge
- \*large
- \*hinge
- \*strange
- \*page
- \*gorge
- \*barge

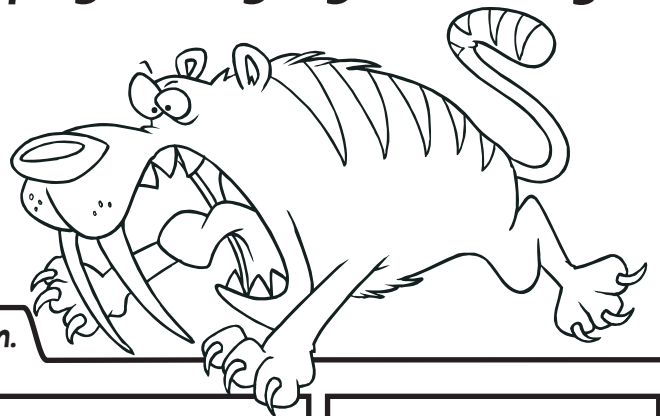

Find the ge words from above and trace them.

cage	hinge	twinge	stage
strange	you	age	do
that	change	barge	can
large	fringe	gorge	page

Write a sentence using the words that are left.

.....

.....

Name: \_\_\_\_\_



Unjumble the ge word to finish the sentences.

1. They will sing on the sgeat \_\_\_\_\_ .

2. Get the egnops \_\_\_\_\_ to mop up.

3. Dad had a twgine \_\_\_\_\_ of pain.

4. The henig \_\_\_\_\_ of the gate is rusty.

5. The barber cut my ergfin \_\_\_\_\_

Write 4 more ge words.  
.....  
.....  
.....  
.....

Write the correct sentence under the picture and finish it.

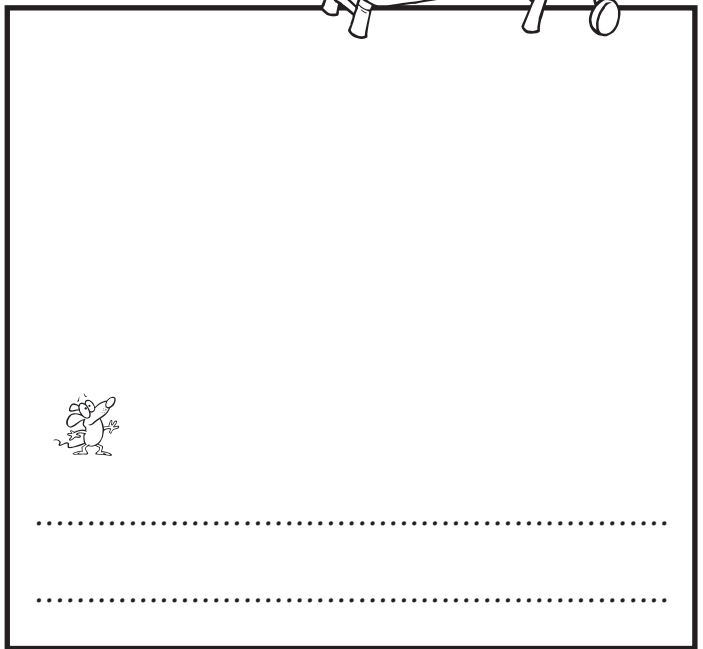
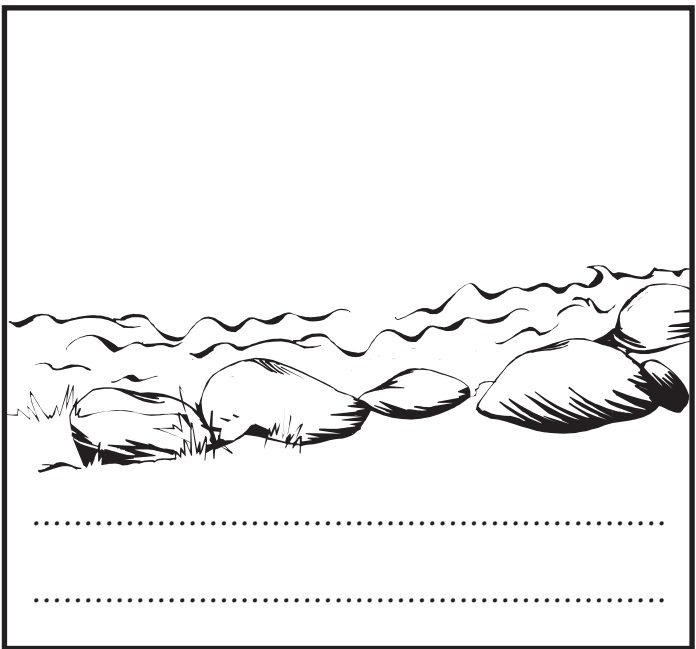
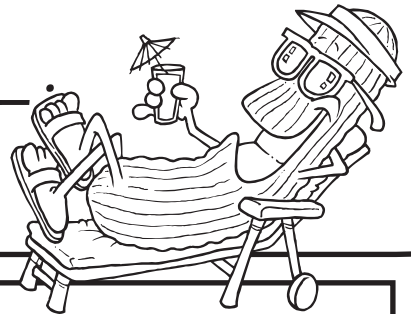

A huge elephant is near the little mouse.  
The barge is on the river.

Name: \_\_\_\_\_

air

Write the missing letters. Join the word and the picture.

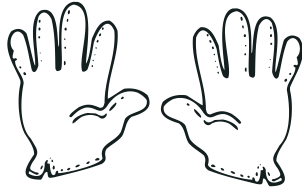

.....craft

f.....y

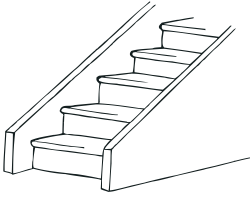

ch.....

p.....

h.....

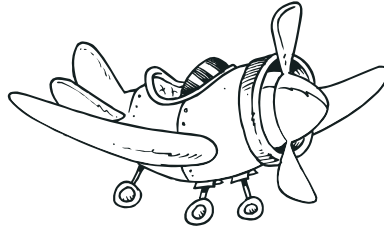

st.....rs

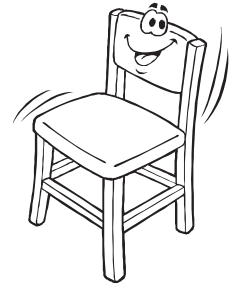

Write the air words again and circle the air sound.



.....  
.....  
.....



.....  
.....  
.....

Use air words in the sentences.

fair

Our car has an .....

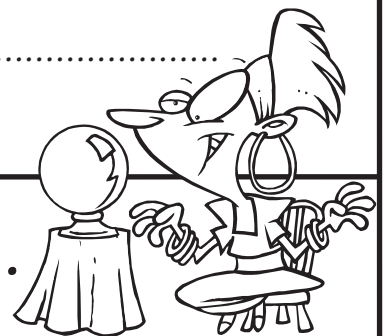

airbag

Mum and I went to the .....

hairdresser

My pop lives on a ..... farm.

dairy

We had fun at the .....

Name: \_\_\_\_\_

# air

Finish the crossword using these words.

**ACROSS**

- 2. Transport over the snow.
- 6. You use this on your hair.
- 8. Part of a golf course.
- 9. To fix something.
- 10. Transport through the sky.

**DOWN**

- 1. Planes take off from an \_\_\_\_\_.
- 3. Safety for cars.
- 4. Milk comes from a \_\_\_\_\_.
- 5. Something to sit on.
- 7. Two things the same.



- hairbrush
- airport
- chairlift
- dairy
- fairway
- aircraft
- pair
- repair
- chair
- airbag

Write the *air* words under the pictures.

**aircraft    chair    dairy    fairy    haircut    stairs**

\_\_\_\_\_

\_\_\_\_\_

\_\_\_\_\_

\_\_\_\_\_

\_\_\_\_\_

\_\_\_\_\_



Name: \_\_\_\_\_

are

Find the *are* words in the puzzle.

i	q	b	m	f	x	h	a
l	l	e	a	e	a	m	h
g	y	c	e	r	a	l	g
e	s	s	e	a	e	e	a
r	h	c	m	c	r	m	b
a	a	a	m	a	a	w	l
t	r	r	f	r	d	h	t
s	e	e	e	r	a	n	s

- \*care
- \*glare
- \*stare
- \*bare
- \*hare
- \*share
- \*dare
- \*mare
- \*scare
- \*fare
- \*rare
- \*snare



Find the *are* words from above and trace them.

fare

share

care

mare

rare

like

stare

we

dare

snare

scare

bare

read

glare

to

hare

Write a sentence using the words that are left.

.....  
.....

Name: \_\_\_\_\_

are

Unjumble the *are* word to finish the sentences.

1. That gem is very *arre* \_\_\_\_\_ .
2. You don't *ecsar* \_\_\_\_\_ me.
3. The rabbit is in the *nsrae* \_\_\_\_\_ .
4. Is your dad *ewara* \_\_\_\_\_ of that.
5. Take *acer* \_\_\_\_\_ when you swim.

Write 4 more  
*are* words.

.....

.....

.....

.....



Write the correct sentence under the picture and finish it.



.....

.....

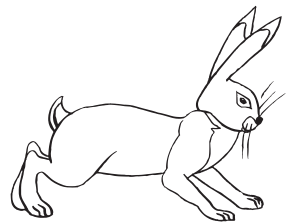

.....

.....

The *hare* is in the *snare*.  
The *birds* are not *scared* of the *scarecrow*.

Name: \_\_\_\_\_

# REVISION

.....ge      air      .....ce  
are

Write the correct word under the pictures.

<b>dance</b>	<b>cage</b>	<b>stairs</b>	<b>sponge</b>
<b>glare</b>	<b>chair</b>	<b>face</b>	<b>scare</b>

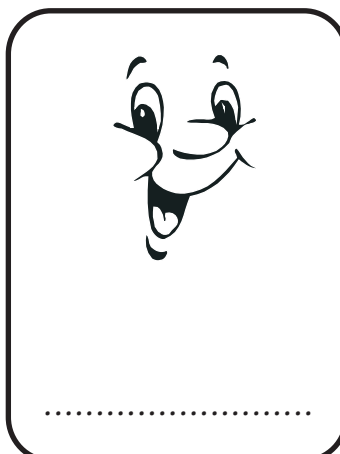
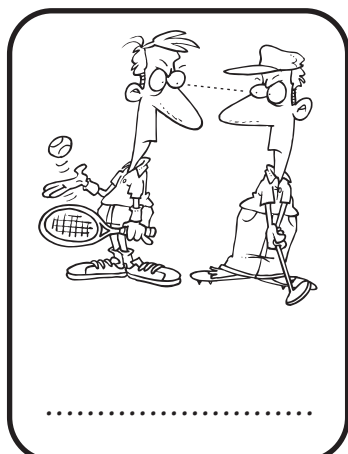
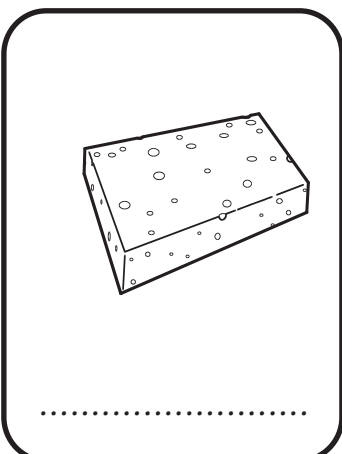
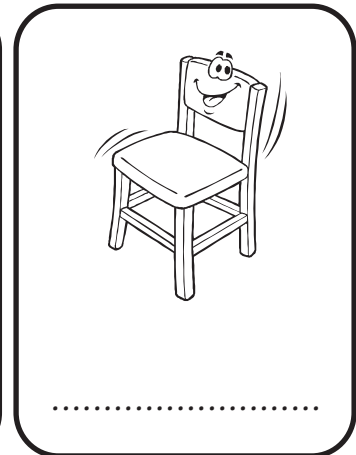
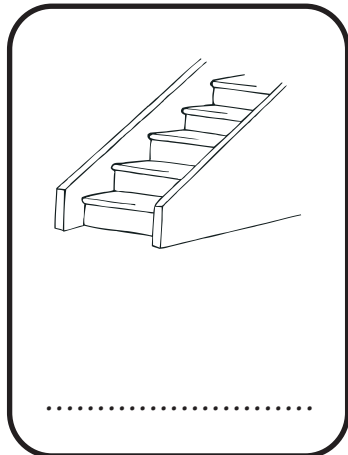
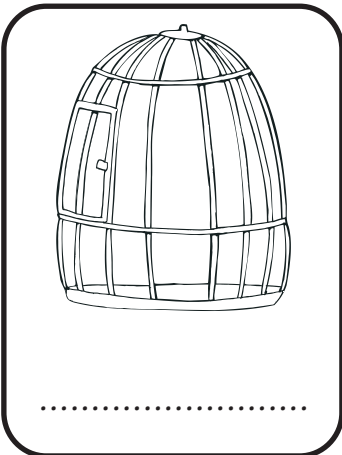

Write words that have the same sound.

**mice**

.....

.....

.....

**stage**

.....

.....

.....

**pair**

.....

.....

.....

**care**

.....

.....

.....

Name: \_\_\_\_\_

# REVISION

.....ge      air      .....ce  
are

Write the word to finish the sentence.

1. They walked down into the \_\_\_\_\_. *silence*
2. The cows went into the \_\_\_\_\_. *stare*
3. We do our work in \_\_\_\_\_. *dairy*
4. Please don't \_\_\_\_\_ at us. *space*
5. Is there any \_\_\_\_\_ near you? *gorge*



Write the sound to finish the words.

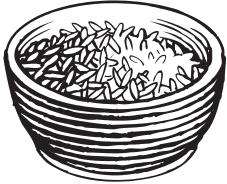

ri.....



f.....y

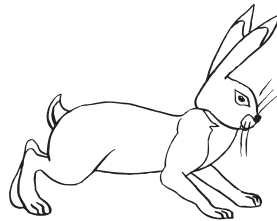

h.....

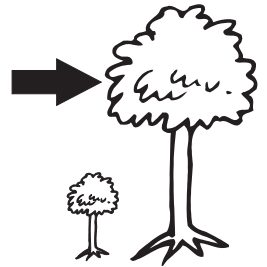

lar.....



sc.....crow

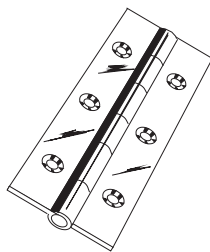

hin.....



m.....



h.....

Name: \_\_\_\_\_

ear

Write the missing letters. Join the word and the picture.

g.....s



sh.....

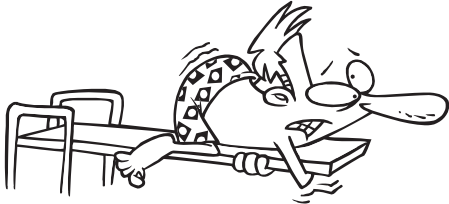
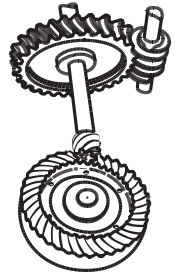

.....



f.....

t.....s

sp.....



Write the ear words again and circle the ear sound.



.....  
.....  
.....



.....  
.....  
.....

Use ear words in the sentences.

rear

Stand ..... me.



near

I got a ..... of dirt on my dress.

smear

Did you ..... what I said?

hear

They are at the ..... of the bus.

Name: \_\_\_\_\_

# ear

Finish the crossword using these words.

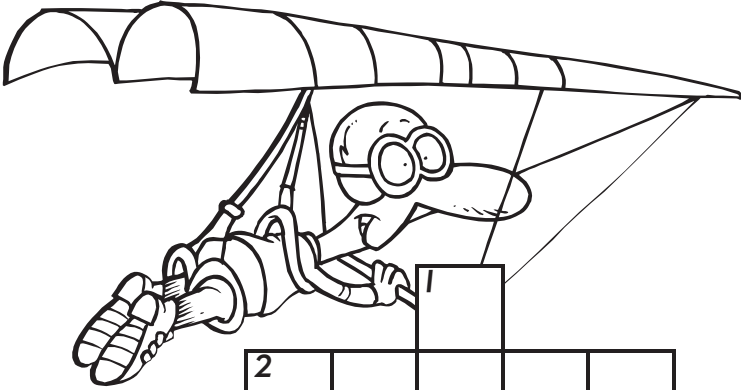

**ACROSS**

2. A weapon.

4. \_\_\_\_\_ is one of your senses.

7. The magician made it \_\_\_\_\_.

8. Go to the \_\_\_\_\_ of the bus.

10. \_\_\_\_\_ are a part of a car.

**DOWN**

1. To be frightened.

3. Twelve months is a \_\_\_\_\_.

5. Stand \_\_\_\_\_ to me.

6. The glass was \_\_\_\_\_ and shiny.

9. Your \_\_\_\_\_ is part of your face.

- clear
- disappear
- rear
- near
- year
- ear
- hearing
- fear
- spear
- gears

Write the *ear* words under the pictures.

earrings    new year    smear    hear    shear    ear

□ □ □ □ □

□ □ □

□ □ □ □ □ □ □ □

□ □ □ □ □ □ □

□ □ □ □ □ □ □ □ □

□ □ □ □ □ □ □

Name: \_\_\_\_\_

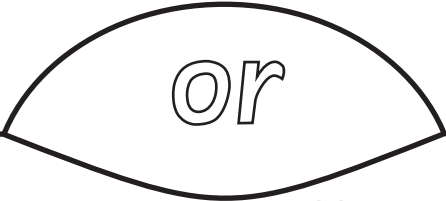

Find the or words in the puzzle.

m	w	o	r	k	i	n	g
w	o	r	s	e	o	s	v
e	r	t	w	n	h	a	i
f	k	u	o	t	u	i	s
f	e	y	r	r	d	l	i
o	d	o	k	r	d	o	t
r	w	d	o	n	o	r	o
t	u	w	o	r	k	e	r

- \*word
- \*motor
- \*effort
- \*work
- \*sailor
- \*worker
- \*worse
- \*visitor
- \*working
- \*worth
- \*donor
- \*worked

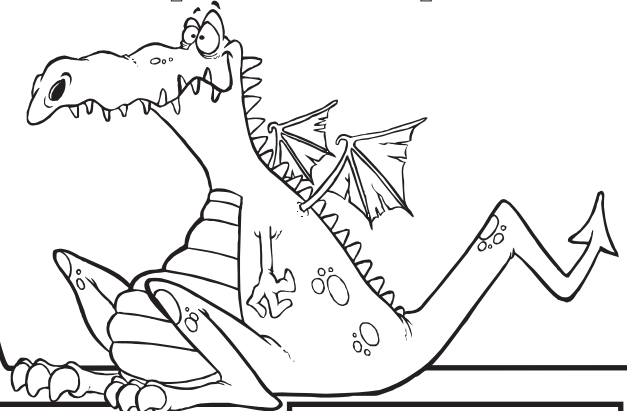

Find the or words from above and trace them.

donor	visitor	come	work
effort	can't	word	working
worse	motor	worked	you
why	worker	worth	sailor

Write a sentence using the words that are left.

.....

.....

Name: \_\_\_\_\_

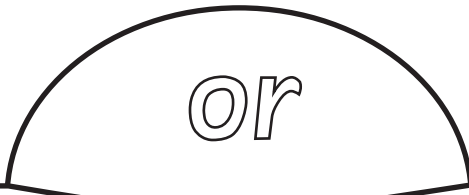

Unjumble the or word to finish the sentences.

1. Are you grwokin \_\_\_\_\_ tonight?

2. I haven't done my wohmeork \_\_\_\_\_.

3. She had the rstow \_\_\_\_\_ time.

4. That was a huge fefrot \_\_\_\_\_.

5. Dad's toomr \_\_\_\_\_ broke down.

Write 4 more  
or words.  
.....  
.....  
.....  
.....



Write the correct sentence under the picture and finish it.

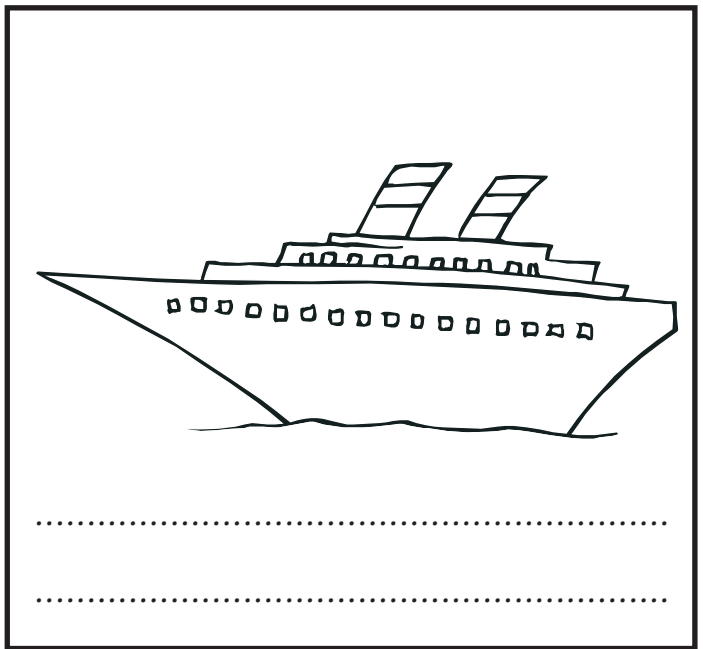
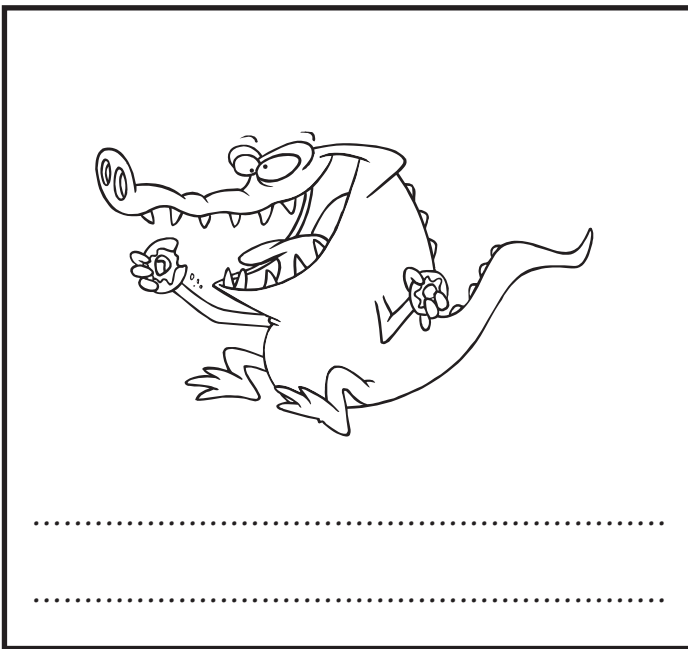

The alligator is on a log.  
The sailor is on the ship.



Name: \_\_\_\_\_



Write the missing letters. Join the word and the picture.

.....one



ele.....ant

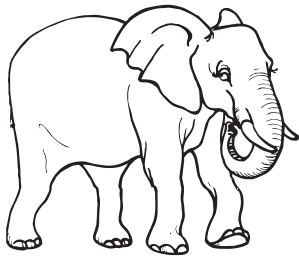

tro.....y

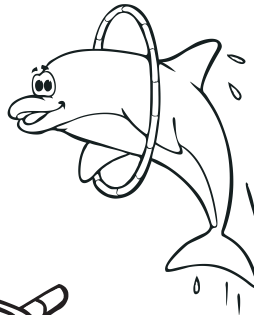

.....oto

dol.....in

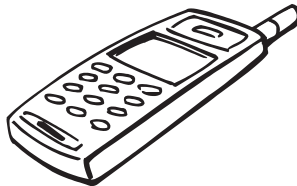

gra.....

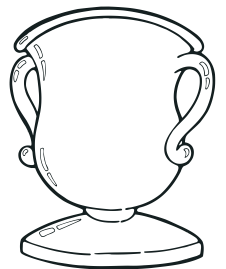

Write the ph words again and circle the ph sound.



.....  
.....  
.....



.....  
.....  
.....

Use ph words in the sentences.

orphan I have a ..... called Bill.

nephew ..... is my best friend.

Phil We got her .....

autograph He is an .....

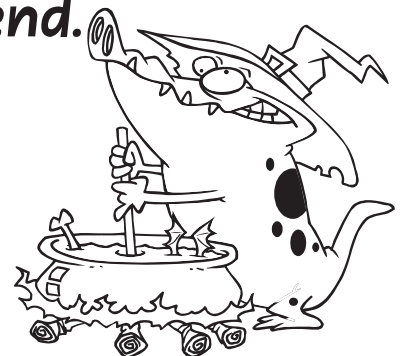

Name: \_\_\_\_\_



Finish the crossword using these words.

**ACROSS**

- 2. A person without parents.
- 6. A musical instrument.
- 7. Your sister's son is your \_\_\_\_\_.
- 9. A \_\_\_\_\_ lets you talk louder.
- 10. A huge storm.

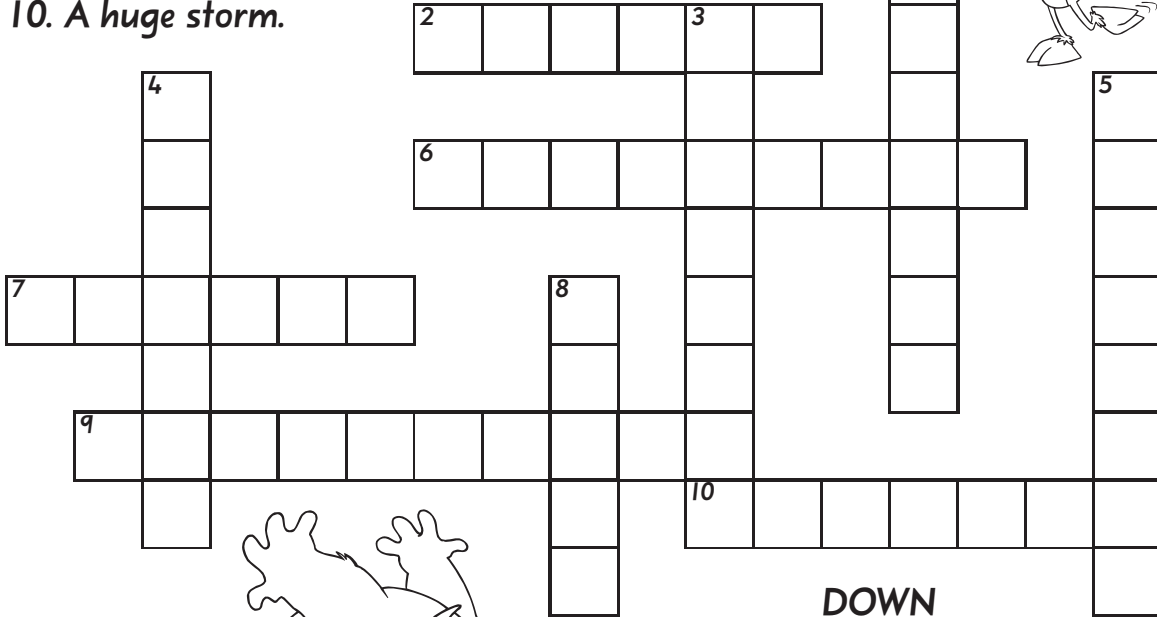

- alphabet
- orphan
- microphone
- saxophone
- photo
- phonics
- typhoon
- elephant
- dolphin
- nephew

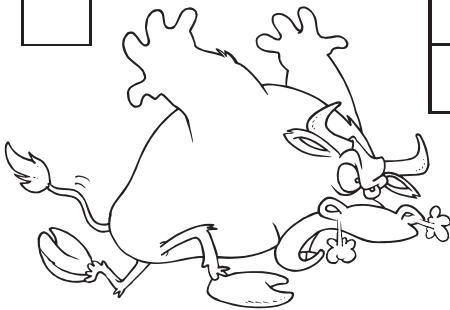

**DOWN**

- 1. Sounding out words is \_\_\_\_\_.
- 3. The letters from a to z.
- 4. A mammal that lives in the sea.
- 5. The biggest land mammal.
- 8. A \_\_\_\_\_ is taken with a camera.

Write the ph words under the pictures.

graph phone typhoon photo dolphin trophy

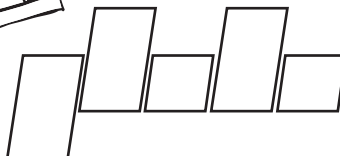
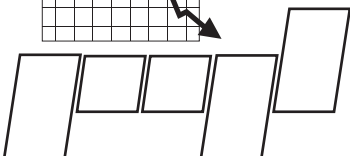
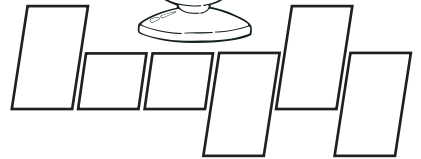
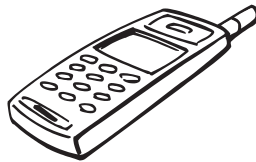
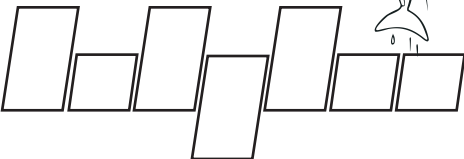
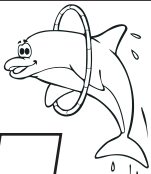

Name: \_\_\_\_\_

ie

Find the ie words in the puzzle.

r	r	e	t	r	i	e	u	e
p	i	e	c	e	i	u	o	m
i	f	i	e	l	d	s	s	s
x	x	f	e	i	r	b	h	h
d	t	h	i	e	f	a	r	i
g	r	i	e	f	a	q	i	e
a	b	e	l	i	e	u	e	l
f	e	i	h	c	j	e	k	d

- \*chief
- \*relief
- \*movie
- \*brief
- \*piece
- \*shield
- \*thief
- \*believe
- \*field
- \*grief
- \*shriek
- \*retrieve

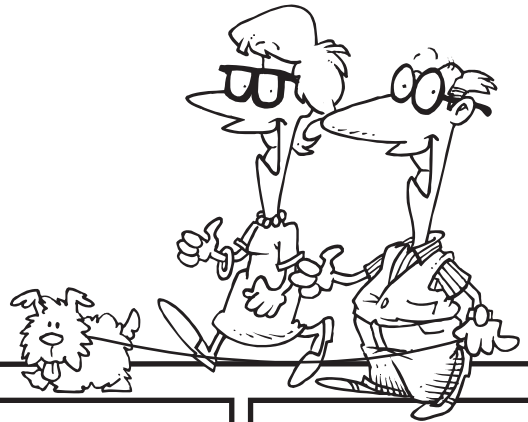

Find the ie words from above and trace them.

piece	shriek	thief	chief
movie	brief	time	what
the	believe	field	relief
grief	shield	is	retrieve

Write a sentence using the words that are left.

.....

.....

Name: \_\_\_\_\_

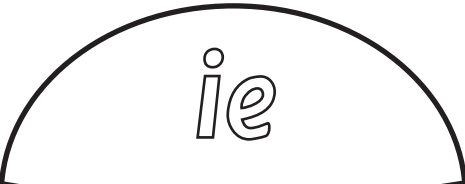

Unjumble the ie word to finish the sentences.

1. The police found the *fhtie* \_\_\_\_\_ .

2. They met the Indian *hieffc* \_\_\_\_\_ .

3. She stayed very *yerbifl* \_\_\_\_\_ .

4. How many *icesep* \_\_\_\_\_ are there?

5. We all went to the *veisom* \_\_\_\_\_ .

Write 4 more  
ie words.  
.....  
.....  
.....  
.....

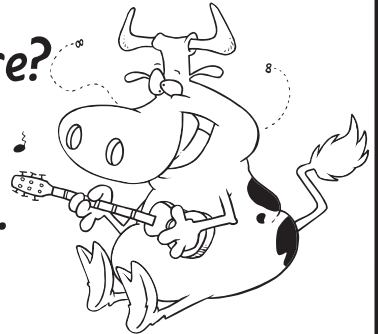

Write the correct sentence under the picture and finish it.

.....  
.....

.....  
.....

The *chief* is in the *field*.  
Mum cut the *pizza* into *pieces*.

Name: \_\_\_\_\_

# REVISION

ear  
or ie ph

Write the correct word under the pictures.

spear	phone	tears	sailor
dolphin	thief	homework	chief

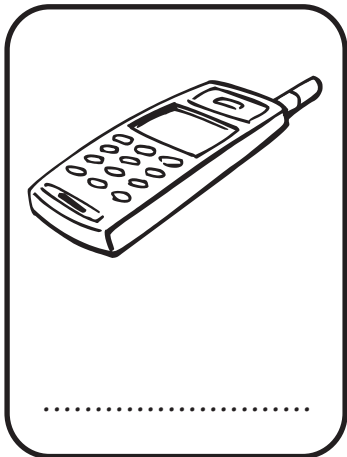
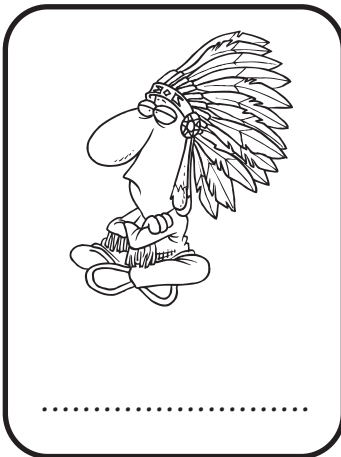
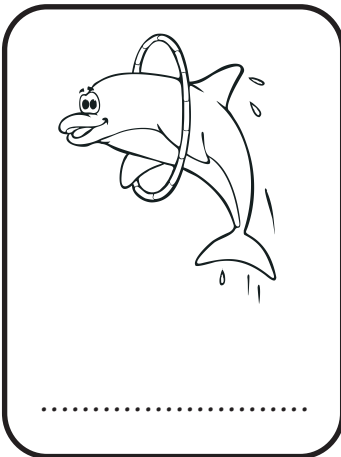
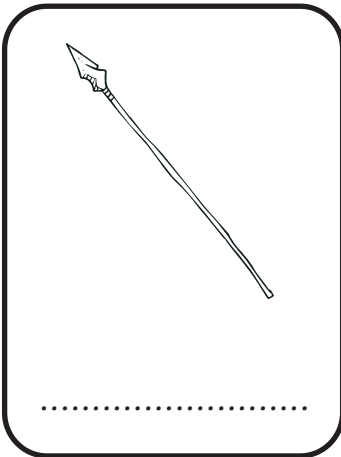
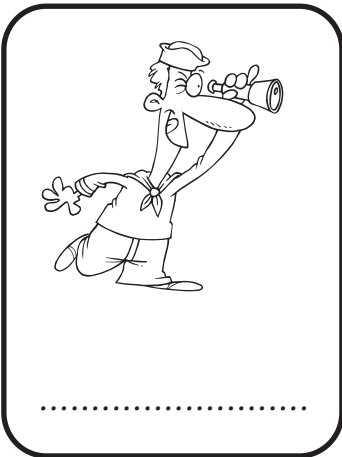

Write words that have the same sound.

near

.....

.....

.....

worse

.....

.....

.....

nephew

.....

.....

.....

brief

.....

.....

.....

Name: \_\_\_\_\_

# REVISION

ear  
or ie ph

Write the word to finish the sentence.

1. That took too much \_\_\_\_\_ . near
2. Does your car have many \_\_\_\_\_ ? trophy
3. Can you sit \_\_\_\_\_ her? relief
4. She got a \_\_\_\_\_ for winning. effort
5. That was a big \_\_\_\_\_ . gears



Write the sound to finish the words.

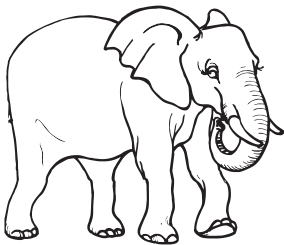

ele.....ant

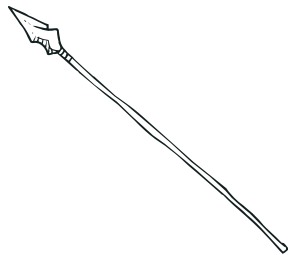

sp.....

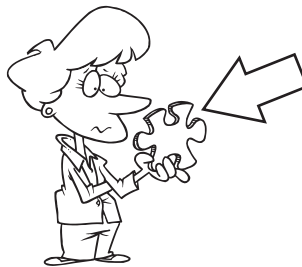

p.....ce



alligat.....



f.....ld



sail.....



sh.....



ty.....oon

Name: \_\_\_\_\_

# silent h

Write the missing letters. Join the word and the picture.

yog...urt



sc...ool

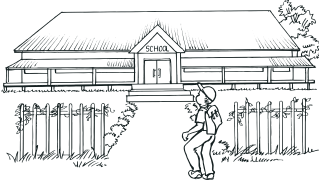
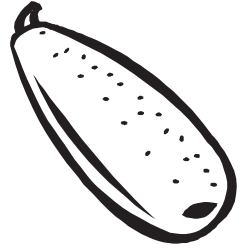

zucc...ini



g...ost

ding...y

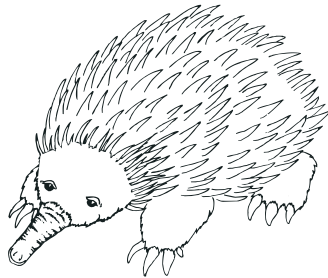

ec...idna



Write the silent h words again and circle the silent h sound.



.....



.....



.....



.....



.....



.....

Use silent h words in the sentences.

ache

Try to always be .....

spaghetti

What ..... of the day is it?

honest

Dad has an ..... in his foot.

hour

We had ..... for dinner.

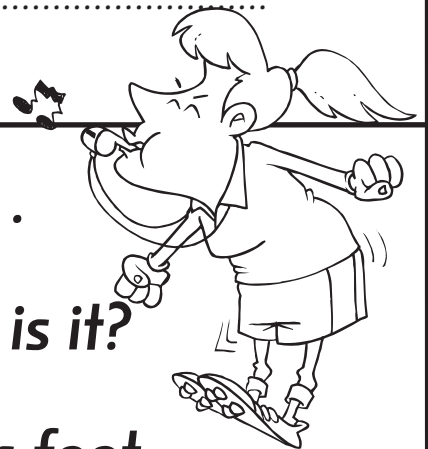

Name: \_\_\_\_\_

# silent h

Finish the crossword using these words.

## ACROSS

2. A small rowing boat.
5. To scrape with a knife.
6. A type of vegetable.
8. You go to \_\_\_\_\_ to learn.
9. A type of sailing boat.

- rhubarb  
rhythm  
whine  
whisk  
whittle

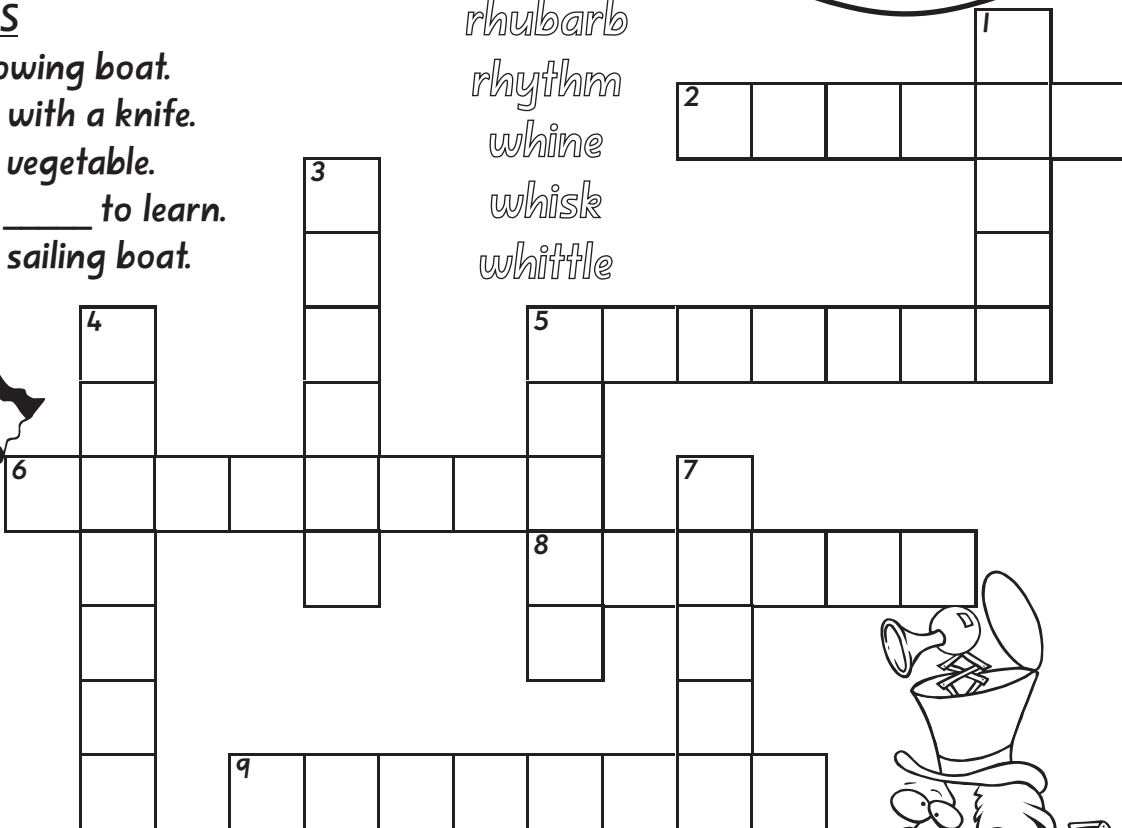

## DOWN

1. To complain a lot.
3. The beat in music.
4. \_\_\_\_\_ is a vegetable used in desserts.
5. A \_\_\_\_\_ mixes things.
7. Words that sound the same.

- rhyme  
school  
dinghy  
zucchini  
schooner

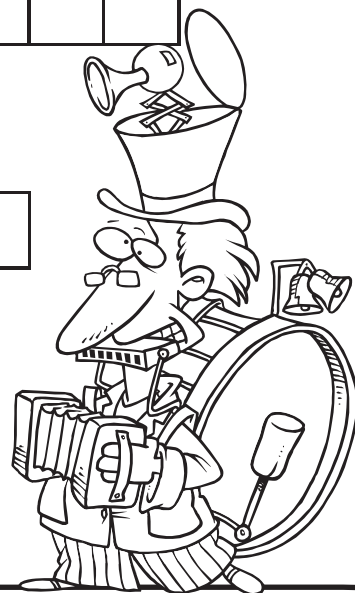

Write the silent h words under the pictures.

vehicle    spaghetti    rhino    whip    whisk    ache

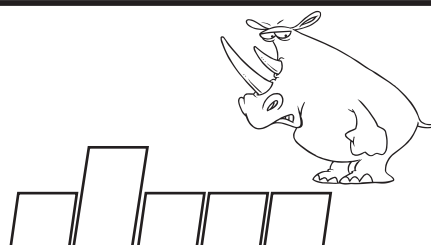
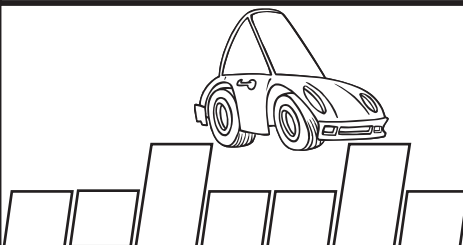
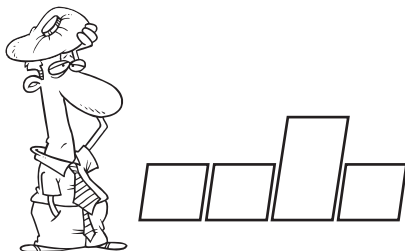
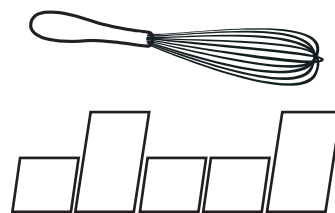
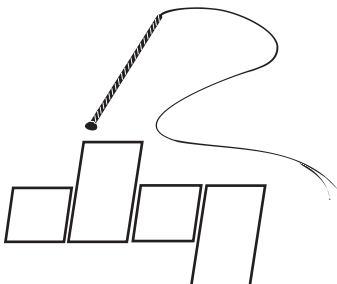
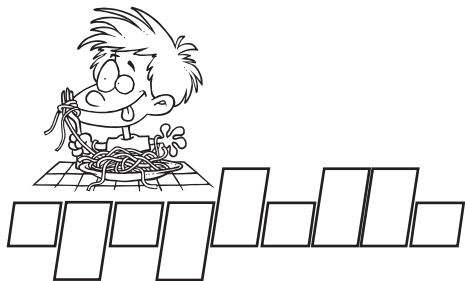



Name: \_\_\_\_\_

# silent b

Find the *silent b* words in the puzzle.

m	d	b	b	b	t	x	b
p	l	u	m	b	e	r	m
a	a	u	u	i	m	a	u
c	h	o	r	z	l	o	n
t	d	b	c	i	a	c	t
p	w	o	m	w	m	a	w
h	m	b	k	u	b	f	b
b	m	o	b	r	d	r	o

- \*bomb
- \*lamb
- \*climb
- \*comb
- \*limb
- \*plumber
- \*crumb
- \*numb
- \*tomb
- \*dumb
- \*thumb
- \*doubt



Find the *silent b* words from above and trace them.

dumb

climb

bomb

doubt

thumb

lamb

tomb

comb

crumb

your

how

is

plumber

limb

numb

mum

Write a sentence using the words that are left.

.....  
.....

Name: \_\_\_\_\_

# silent b

Unjumble the silent b word to finish the sentences.

1. My arm went *unb*m \_\_\_\_\_ .
2. Mum likes to *cm*bo \_\_\_\_\_ my hair.
3. The baby sucks his *htub*m \_\_\_\_\_ .
4. Dad cooked *blma* \_\_\_\_\_ chops.
5. We dropped bread *sucr*mb \_\_\_\_\_ on the floor.

Write 4 more  
silent b words.

.....

.....

.....

.....

Write the correct sentence under the picture and finish it.

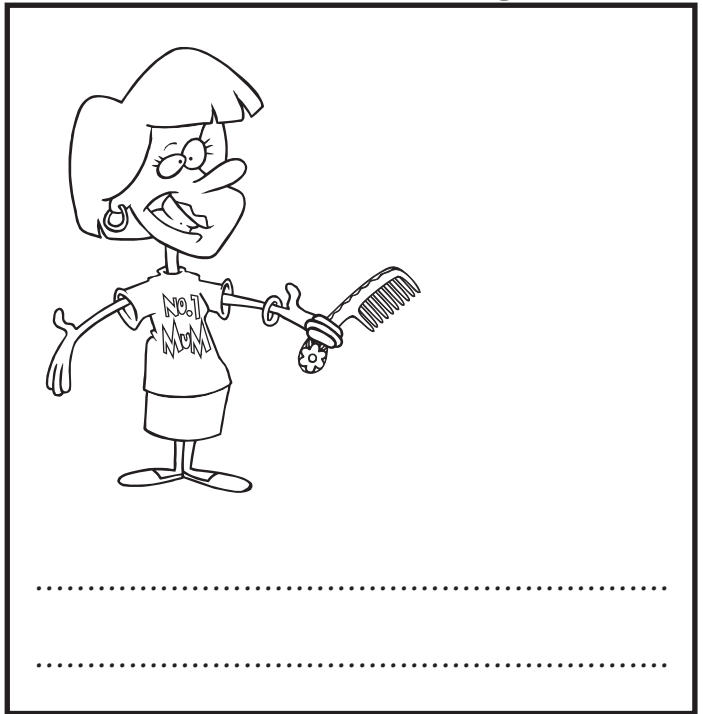
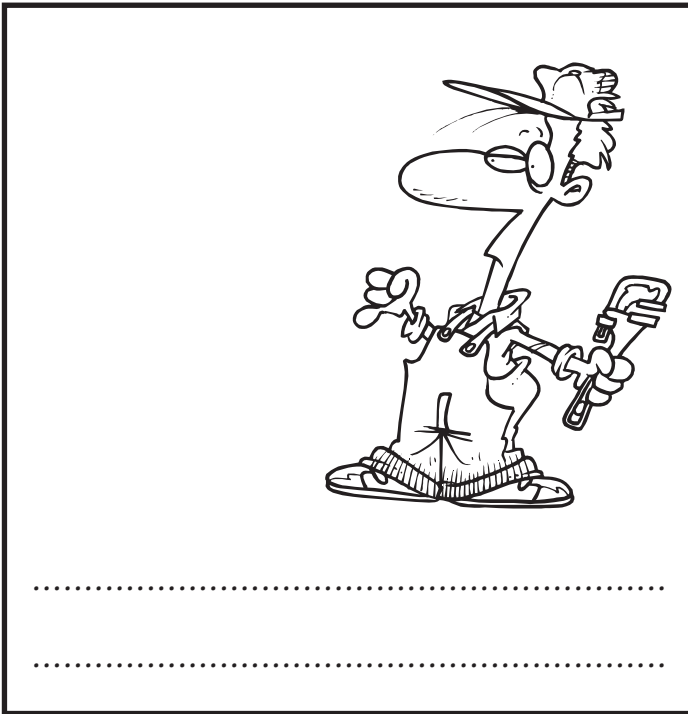
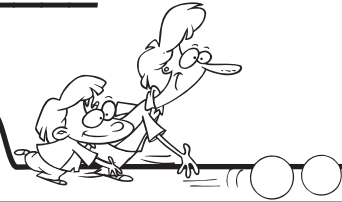

The plum**b**er fixes the tap.  
Mum com**b**s the baby's hair.

Name: \_\_\_\_\_

# silent k

Write the missing letters. Join the word and the picture.

..... **night**



..... **nee**

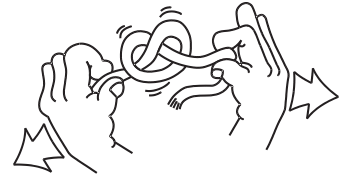

..... **nife**



..... **neel**

..... **nit**

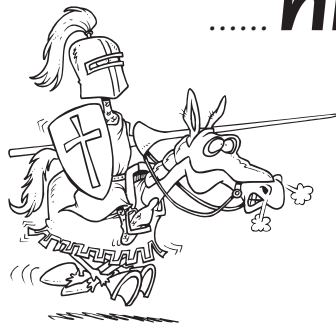

..... **not**

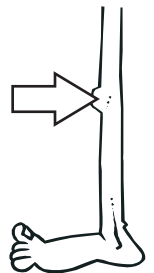

Write the silent k words again and circle the silent k sound.



.....  
.....  
.....



.....  
.....  
.....

Use silent k words in the sentences.

**knit**

Do you ..... where to go?

**know**

Can you ..... on the ground?

**kneel**

Grandma likes to ..... jumpers.

**knife**

Chop the vegetables with the .....

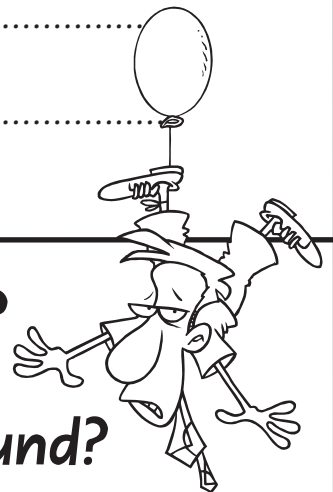

Name: \_\_\_\_\_

# silent k

Finish the crossword using these words.

## ACROSS

- I \_\_\_\_\_ on the door.
- I tied a \_\_\_\_\_ in the rope.
- This lets your leg bend.
- She will \_\_\_\_\_ a jumper.
- He will \_\_\_\_\_ the dough.

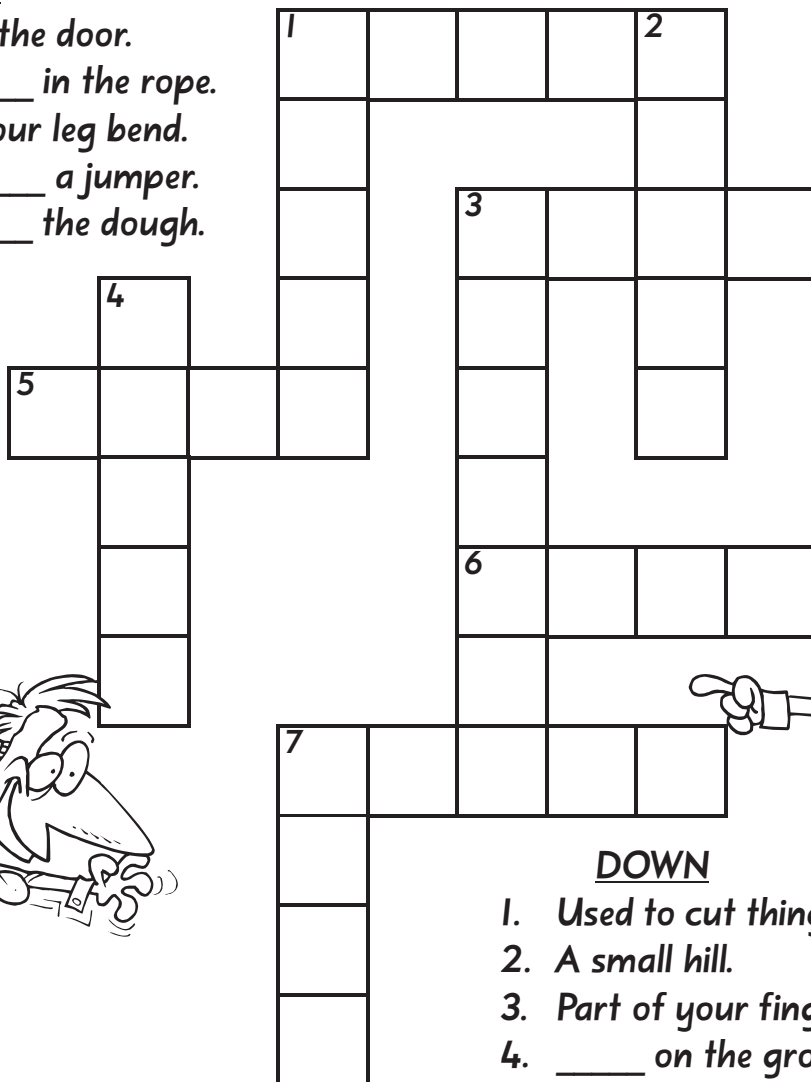

- knuckle
- knot
- knoll
- knit
- knock
- knife
- knob
- knee
- knead
- kneel

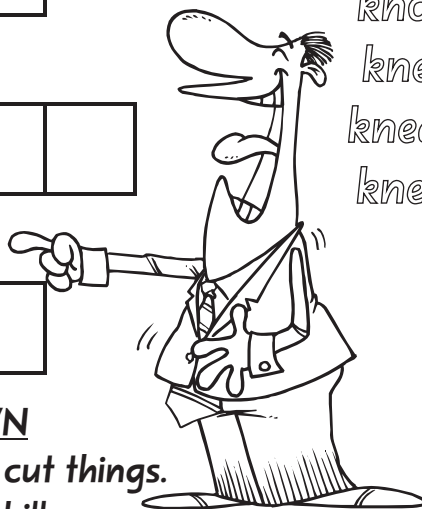

## DOWN

- Used to cut things.
- A small hill.
- Part of your finger.
- \_\_\_\_\_ on the ground.
- Part of a door.

Write the silent k words under the pictures.

knee

knot

knife

knight

knock

kneel

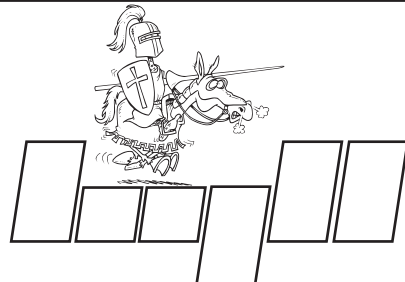
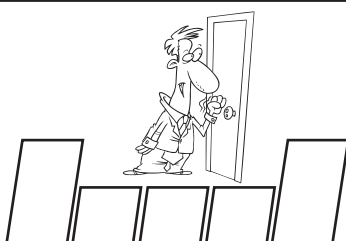
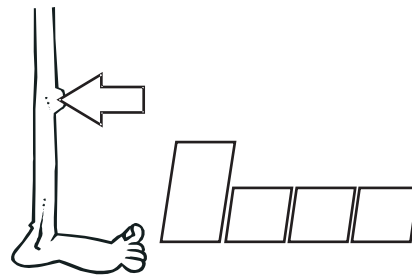
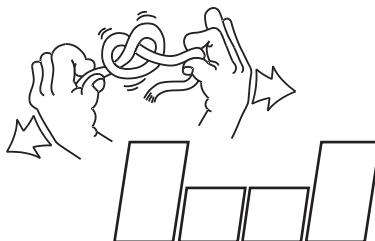
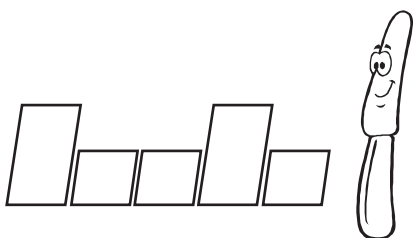

Name: \_\_\_\_\_

# REVISION

silent k

silent b

silent h

Write the correct word under the pictures.

knot	lamb	echidna	thumb
school	knit	ghost	kneel

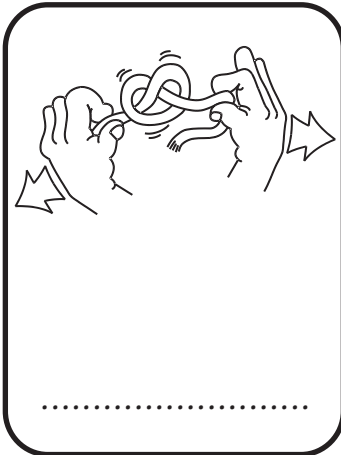
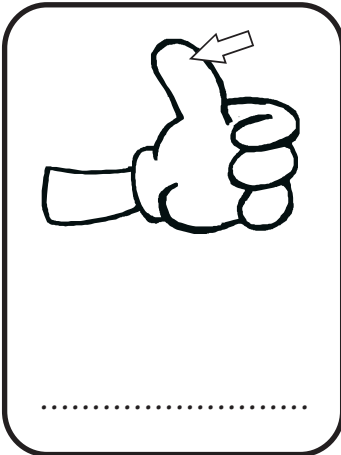
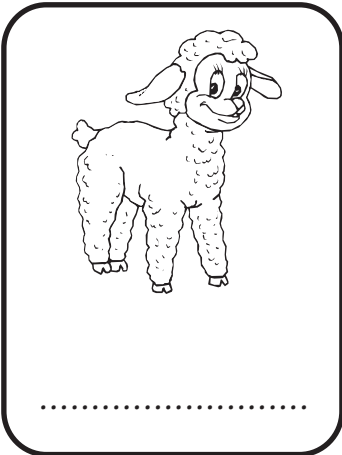
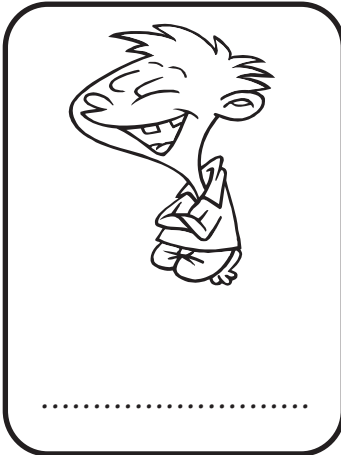
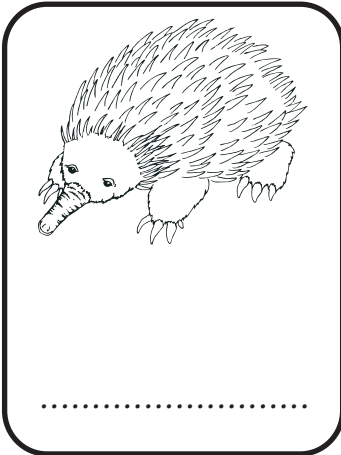

Write words that have the same sound.

**rhyme**

.....

.....

.....

**bomb**

.....

.....

.....

**knob**

.....

.....

.....

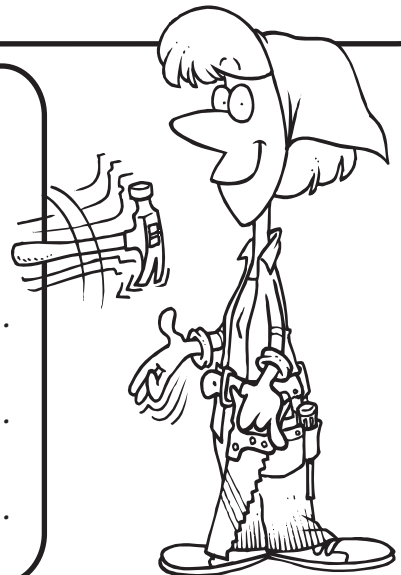

Name: \_\_\_\_\_

# REVISION

silent k

silent h

silent b

Write the word to finish the sentence.

1. The baby sucks her \_\_\_\_\_ . whisk
2. They are going to \_\_\_\_\_ up the hill. rhymes
3. You need to \_\_\_\_\_ the eggs. knuckles
4. My \_\_\_\_\_ are sore. thumb
5. What word \_\_\_\_\_ with that? climb

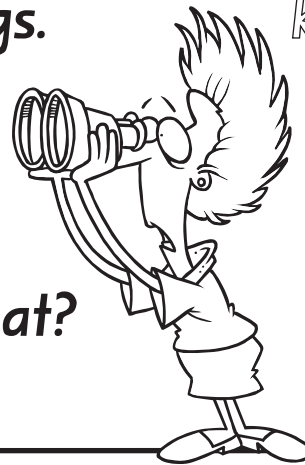

Write the sound to finish the words.



yog.....urt

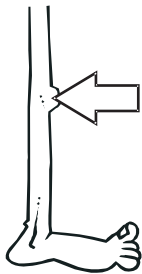

.....nee

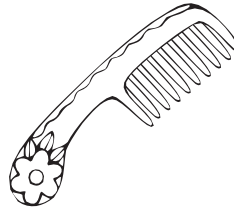

com.....



.....nock



clim.....



ding.....y

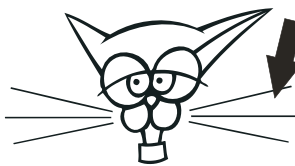

w.....iskers

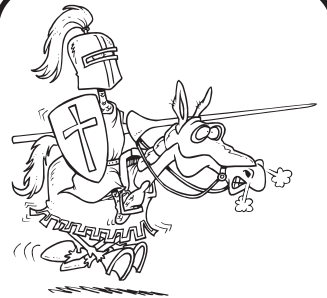

.....night

Name: \_\_\_\_\_

# silent w

Write the missing letters. Join the word and the picture.

.....rite

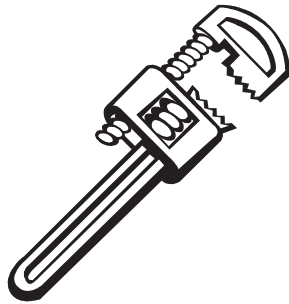

.....reath

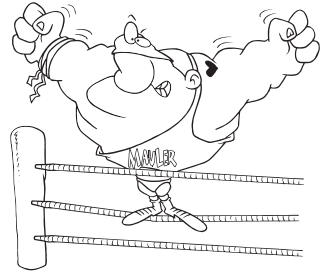

.....rap



.....rench

.....reck



.....restler

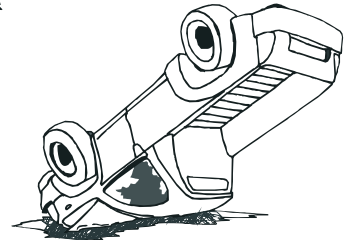

Write the silent w words again and circle the silent w sound.



.....  
.....  
.....



.....  
.....  
.....

Use silent w words in the sentences.

wrinkles That is the ..... answer.

wriggled Dad has lots of .....

write Can you ..... that down?

wrong The little boy ..... in his chair.

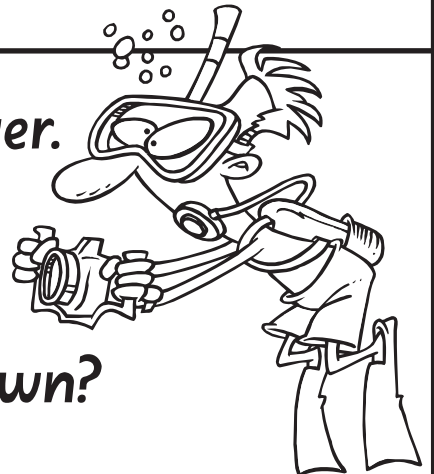

Name: \_\_\_\_\_

Finish the crossword using these words.

silent w

**ACROSS**

- I will \_\_\_\_\_ the present.
- \_\_\_\_\_ like a worm.
- To twist around in pain.
- He will \_\_\_\_\_ a letter.
- A tool for nuts and bolts.

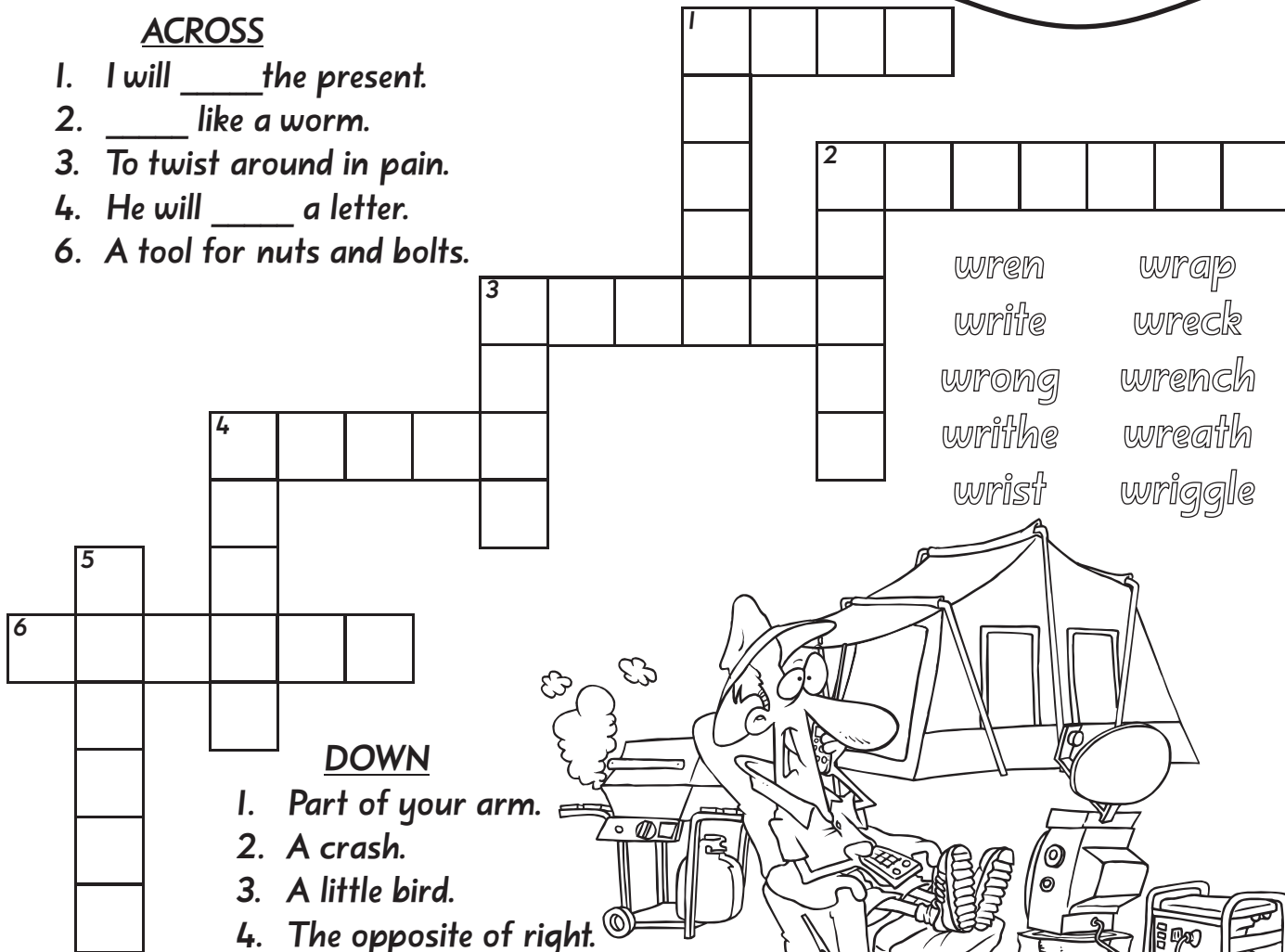

- |        |         |
|--------|---------|
| wren   | wrap    |
| write  | wreck   |
| wrong  | wrench  |
| writhe | wreath  |
| wrist  | wriggle |

**DOWN**

- Part of your arm.
- A crash.
- A little bird.
- The opposite of right.
- A circle of leaves and flowers.

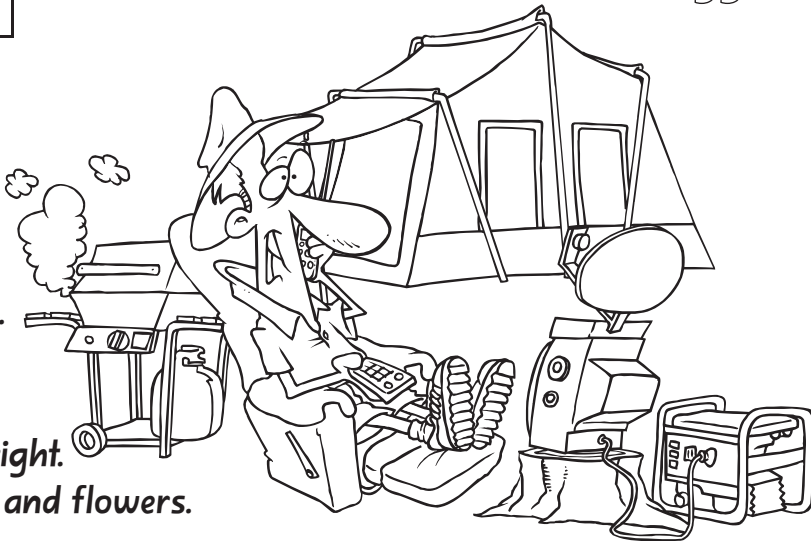

Write the silent w words under the pictures.

wren    write    wreath    wrap    wrench    wrist

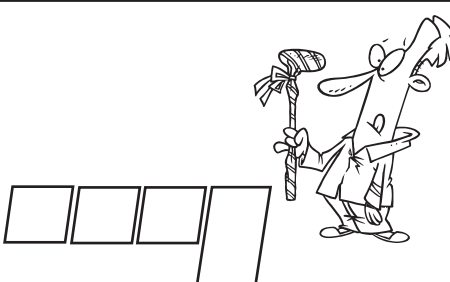
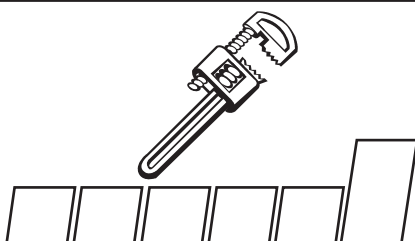
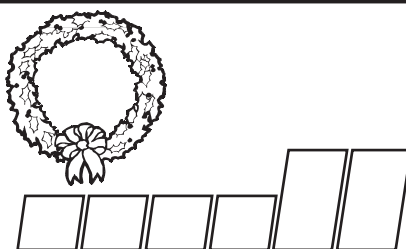
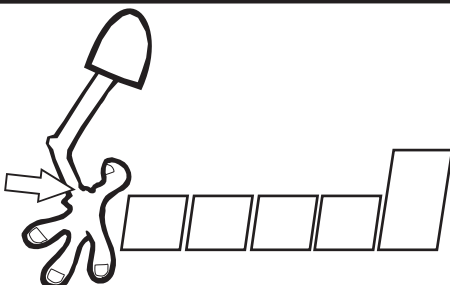
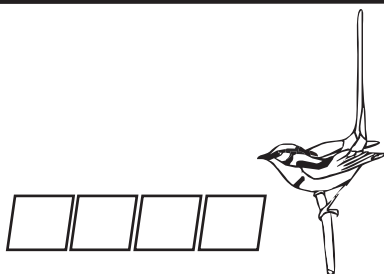



Name: \_\_\_\_\_

# silent t

Find the *silent t* words in the puzzle.

n	x	i	f	e	t	c	h
p	m	u	w	h	l	h	h
a	a	s	i	a	c	c	s
t	t	t	t	t	t	t	k
c	c	c	i	i	g	i	e
h	h	d	w	m	t	p	t
n	o	t	c	h	e	c	c
p	u	s	w	i	t	c	h

- \*fetch
- \*switch
- \*patch
- \*notch
- \*witch
- \*ditch
- \*sketch
- \*match
- \*pitch
- \*stitch
- \*latch
- \*hitch

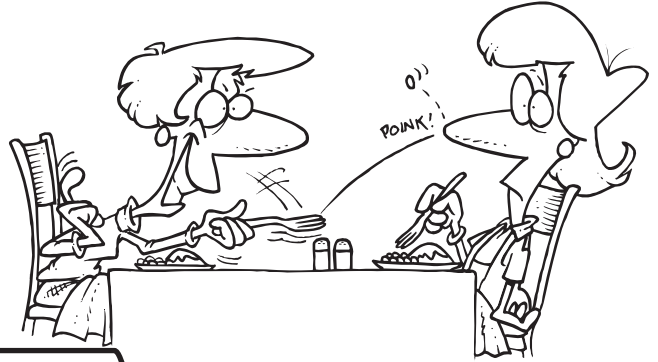

Find the *silent t* words from above and trace them.

match

let

stitch

latch

sketch

fetch

witch

me

too

hitch

pitch

ditch

come

notch

patch

switch

Write a sentence using the words that are left.

.....

.....

Name: \_\_\_\_\_

# silent t

Unjumble the silent t word to finish the sentences.

1. I like to *awhtc* \_\_\_\_\_ the cricket.
2. I hope you don't *chcat* \_\_\_\_\_ a cold.
3. He has an *ytcih* \_\_\_\_\_ leg.
4. The dog went to *chfef* \_\_\_\_\_ the ball.
5. Dad has four *setsithc* \_\_\_\_\_ in his leg.

Write 4 more  
silent t words.

.....  
.....  
.....  
.....

Write the correct sentence under the picture and finish it.



.....  
.....

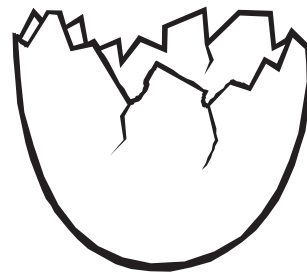

.....  
.....

The **w**itch has a broom stick.  
The **ch**icken hatches out of the egg.

Name: \_\_\_\_\_

# silent l

Find the *silent l* words in the puzzle.

y	n	s	h	o	u	l	d
c	k	a	r	h	a	l	f
s	d	l	u	o	c	c	l
i	y	m	a	p	o	h	a
k	u	o	l	t	a	a	c
w	l	n	l	a	s	l	g
t	w	a	l	k	c	k	m
r	j	u	t	f	j	l	q

- \*calf
- \*talk
- \*palm
- \*half
- \*walk
- \*salmon
- \*chalk
- \*yolk
- \*could
- \*stalk
- \*calm
- \*should



Find the *silent l* words from above and trace them.

yolk	shop	chalk	go
the	walk	could	calf
talk	salmon	to	stalk
calm	half	palm	should

Write a sentence using the words that are left.

.....

.....

Name: \_\_\_\_\_

# silent l

Unjumble the silent l word to finish the sentences.

1. I would like to *atlk* \_\_\_\_\_ to you.
2. That egg has a yellow *kloy* \_\_\_\_\_.
3. Can you please stay *caml* \_\_\_\_\_?
4. Pink *lmosan* \_\_\_\_\_ is good to eat.
5. Give her *falh* \_\_\_\_\_ of your pie.

Write 4 more  
silent l words.

.....  
.....  
.....  
.....

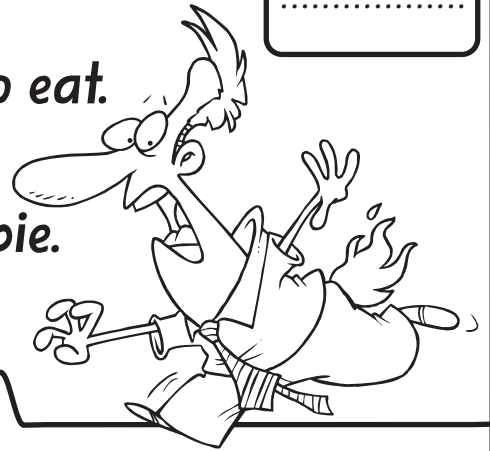

Write the correct sentence under the picture and finish it.

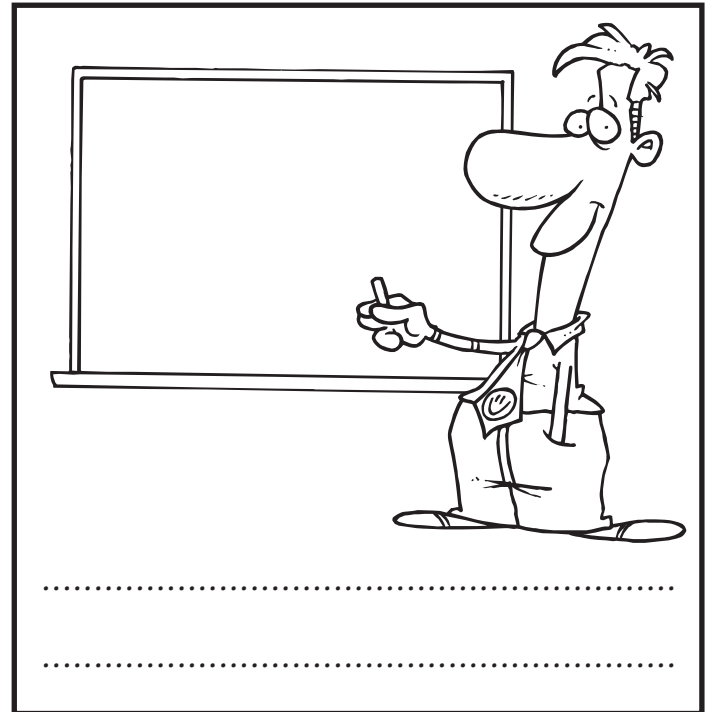
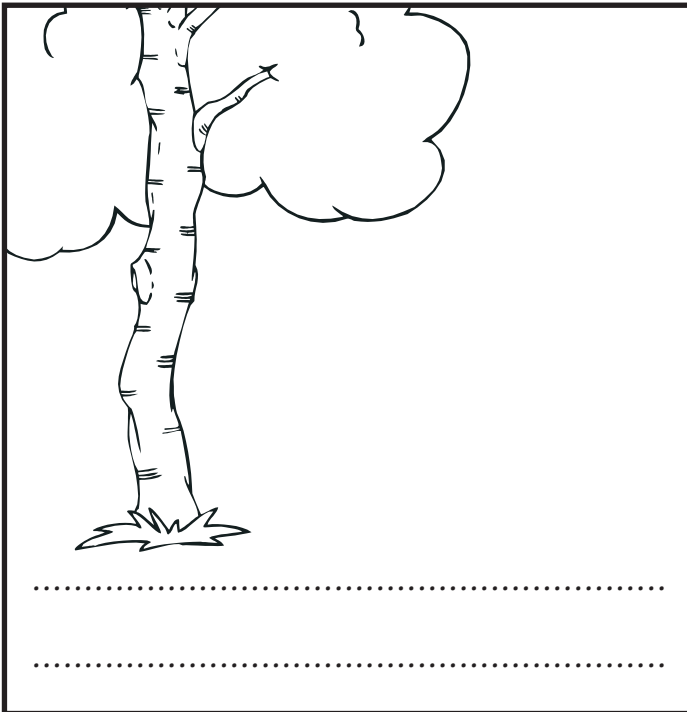

The teacher writes with *chalk* on the blackboard.  
The *calf* is near the big tree.

Name: \_\_\_\_\_

# REVISION

silent w

silent l

silent t

Write the correct word under the pictures.

walk	witch	chalk	hatch
catch	yolk	write	wreck

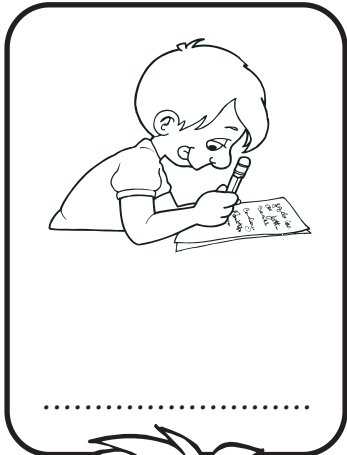
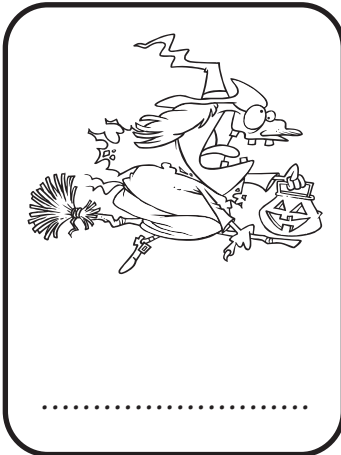
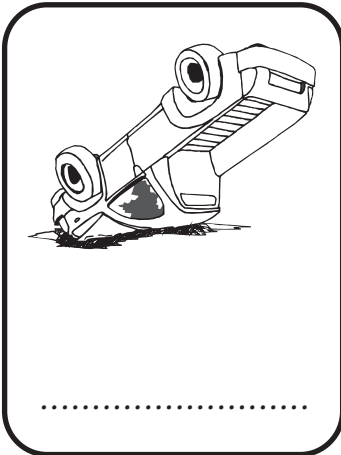
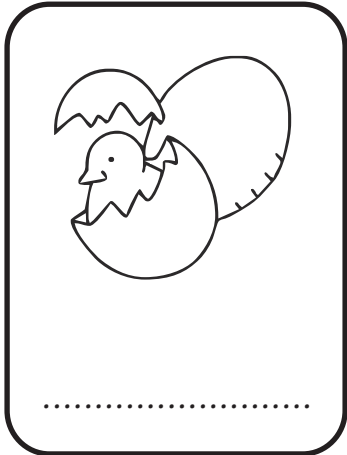
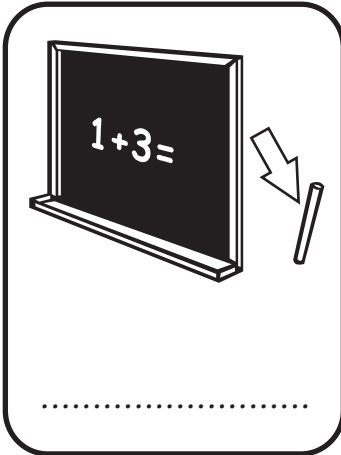
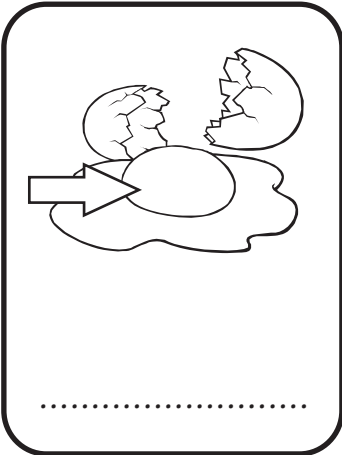

Write words that have the same sound.

wrap

.....

.....

.....

fetch

.....

.....

.....

half

.....

.....

.....

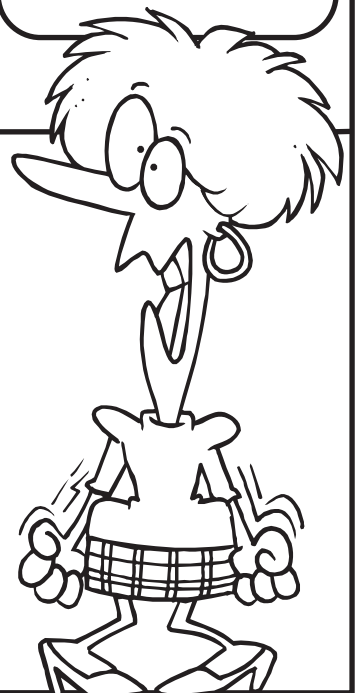

Name: \_\_\_\_\_

# REVISION

silent w

silent l

silent t

Write the word to finish the sentence.

1. He sprained his \_\_\_\_\_ . wrestle
2. Can you do a \_\_\_\_\_ of the tree? fetch
3. The dog likes to \_\_\_\_\_ the ball. half
4. The two boys are going to \_\_\_\_\_ . wrist
5. It is \_\_\_\_\_ time at the football. sketch



Write the sound to finish the words.

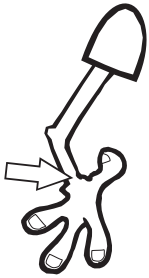

.....rist

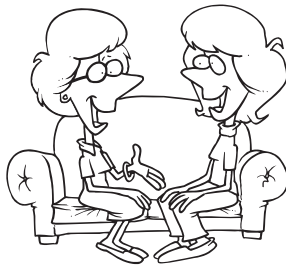

ta.....k



ma.....ches

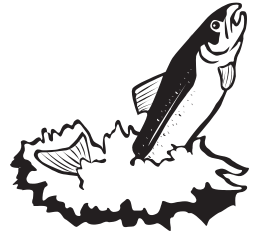

sa.....mon

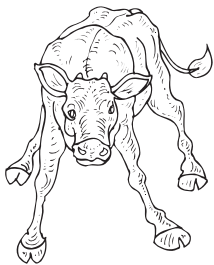

ca.....f



swi.....ch

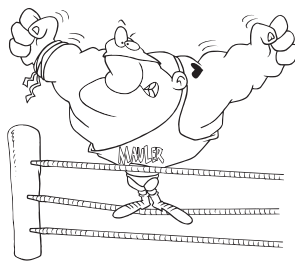

.....restler



.....reath

# WORD LISTS

## long a

ape	fade
bake	game
bale	gate
blame	lake
brake	name
cake	rake
came	snake
cane	take
cave	wave
date	late

## long o

bone	rope
choke	rose
drove	smoke
hole	spoke
home	stone
hope	stove
nose	vote
note	woke
pole	those
rode	joke

## long i

bike	kite
bite	life
bride	like
chime	line
drive	nine
fine	prize
fire	ride
hide	ripe
hire	side
hive	smile

## long u

cube	prune
cute	pure
dune	refuse
flute	rude
fume	rule
fuse	tube
mute	tune
huge	use
June	ute
mule	accuse

## ing

king	sting
ring	string
sing	swing
wing	thing
bring	jingle
cling	mingle
fling	single
singlet	tingle
sling	finger
spring	singer

## ang

bang	slang
fang	sprang
gang	swang
hang	angle
pang	bangle
rang	jangle
sang	mangle
tang	spangle
clang	tangle
prang	angry

## ung

bung	sprung
dung	stung
hung	strung
lung	swung
mung	bungle
rung	hungry
sung	wrung
clung	
flung	
slung	

## y = long e

angry	ugly
body	any
copy	baby
dusty	bunny
empty	cherry
fifty	daddy
handy	dirty
hungry	family
plenty	funny
study	party

## y = long i

by	pry
cry	pylon
crying	python
dry	shy
drying	sky
dynamic	spy
fly	sty
fry	try
my	cycle
nylon	why

# WORD LISTS

oi

boil	point
coin	poise
foil	poison
hoist	quoits
joint	soil
moist	spoil
moisture	toil
oink	toilet
oil	avoid
ointment	choice

ew

blew	new
chew	newt
brew	mildew
crew	nephew
dew	pew
drew	pewter
ewe	skewer
few	stew
flew	threw
jewel	renew

ie

cried	magpie
cries	pie
die	spied
died	spies
dies	tie
flies	tied
fried	ties
lie	tried
lied	science
lies	

ce

brace	lace
chance	lice
dance	mice
device	nice
dice	once
face	pace
fence	piece
fleece	place
grace	police
race	price

ge

age	manage
badge	message
bandage	orange
bridge	page
cabbage	ridge
cage	sausage
edge	savage
hedge	stage
large	strange
ledge	village

air

air	stairs
chair	aircraft
dairy	repair
eclair	airbag
fair	hairbrush
fairy	airport
hair	chairlift
flair	fairway
lair	wheelchair
pair	fairground

are

bare	scare
care	share
dare	snare
fare	spare
hare	stare
glare	ware
mare	warehouse
pare	scarecrow
parents	
rare	

ear

ear	spear
clear	tear
dear	year
hear	
fear	
gear	
near	
rear	
shear	
smear	

or

word	working
work	worked
worse	alligator
worth	worthy
motor	author
sailor	minor
visitor	decorate
homework	visitor
effort	network
worker	artwork



# WORD LISTS

## ph

phone	microphone
telephone	saxophone
nephew	phonics
orphan	typhoon
dolphin	xylophone
elephant	autograph
graph	telegraph
trophy	phantom
photo	pharmacy
alphabet	hemisphere

## ie

brief	shield
belief	shriek
chief	thief
field	wield
frieze	piece
grief	siege
grieve	achieve
niece	movie
priest	hygiene
relief	

## silent h

hour	rhino
ache	rhubarb
echidna	rhyme
school	rhythm
zucchini	whack
dinghy	what
gherkin	when
ghost	which
spaghetti	whine
yoghurt	whisk

## silent b

bomb	tomb
comb	debt
crumb	doubt
dumb	subtle
lamb	climb
limb	
numb	
plumber	
succumb	
thumb	

## silent k

knife	knuckle
knight	knead
knot	kneel
knee	
know	
knoll	
knit	
knock	
knob	
know	

## silent w

who	wriggle
whole	wring
whom	wrinkle
whose	wrist
wrap	write
wrath	wrong
wreck	wrote
wren	two
wrench	answer
wretch	

## silent t

fetch	bustle
notch	fasten
sketch	listen
stitch	nestle
switch	thistle
witch	whistle
soften	wrestle
mortgage	wrestler
castle	
bristle	

## silent l

could	calm
should	palm
would	psalm
calf	qualm
half	salmon
chalk	
stalk	
talk	
walk	
yolk	

‘Advanced Phonics’ will provide the introduction and reinforcement of more difficult phonetic patterns within words.

\* Each sound (phoneme) has two pages of activities and also revision pages to consolidate what the student has learnt.

\* The sounds treated in this book include:

- |          |          |          |          |
|----------|----------|----------|----------|
| long a   | long i   | long o   | long u   |
| ing      | ung      | ang      | y        |
| oi       | ew       | ie       | ce       |
| ge       | air      | are      | ear      |
| or       | ph       | ie       |          |
| silent h | silent b | silent k | silent w |
| silent t | silent l |          |          |

This book is suitable for the following grades in different states.

	NSW	ACT	VIC	TAS	WA	NT	SA	QLD	NZ
K, Prep									
1									
2	✓	✓	✓	✓					
3					✓	✓	✓	✓	✓
4									
5									
6									
7									

LOWER MIDDLE UPPER

**Burrabooks** publications are written by Australian teachers who have had extensive classroom experience.

For more information visit:

[www.burrabooks.com.au](http://www.burrabooks.com.au)

