



**Australian  
Curriculum**



# COMPLETE SINGLE SOUNDS

**BURRABOOKS**  
Educational Worksheets

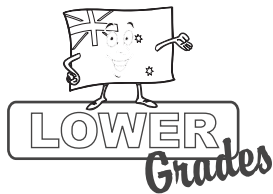

EDUCATIONAL  
WORKSHEETS

# COMPLETE SINGLE SOUNDS

BURRA BOOKS

[www.burrabooks.com.au](http://www.burrabooks.com.au)



## **Complete Single Sounds**

written by Louise and Greg Porich

© Burrabooks Pty Ltd.

First Published 2007

Revised and Reprinted 2008

ABN 22 070 006 085

P. O. Box 611,

Moruya NSW 2537

Ph: 0244 742 355

Fax: 0244 742 399

www.burrabooks.com.au

Some pages in **Complete Single Sounds** have been previously published in the following titles:

- Beginning to Read
- Starting Sounds Workbook
- Using Sounds
- Sound Activities
- Learning to Read ~ Single Sounds

All rights reserved.

### **COPYING FOR EDUCATIONAL PURPOSES**

The purchaser of this book is granted permission by the publisher to make copies of the pages within the book, beyond their rights under the Australian Copyright Act 1968 (the Act), provided that the number of copies made does not exceed the number reasonably required for use in one classroom only; that copies are only made by photocopying and are not copied, stored or transmitted by any electronic or digital means; copies are not sold or lent. Copying of this book outside this licence may fall within the educational statutory licence under the Act.

### **COPYING FOR OTHER PURPOSES**

Unless copying is specifically permitted by the educational statutory licence, the licence granted to the purchaser of this book or the fair dealing clause in the Act (for the purposes of study, research, criticism or review), no part of this book may be reproduced, stored in a retrieval system, transmitted in any form or by any means without prior written permission from the publisher.

Some images used with permission of Ron Leishman from www.toonaday.com.

As with all Burrabooks publications every attempt is made to acknowledge copyright. Any infringements are purely coincidental and the publisher offers apologies where applicable.

ISBN: 978 1 92098 243 0

**www.burrabooks.com.au**  
**mail@burrabooks.com.au**  
**Latest books, news & more.**

**BUR-4602**

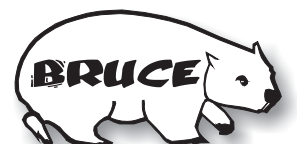

# a

Trace the *a* sounds.



**a**mbulance



Colour the pictures that start with *a*.

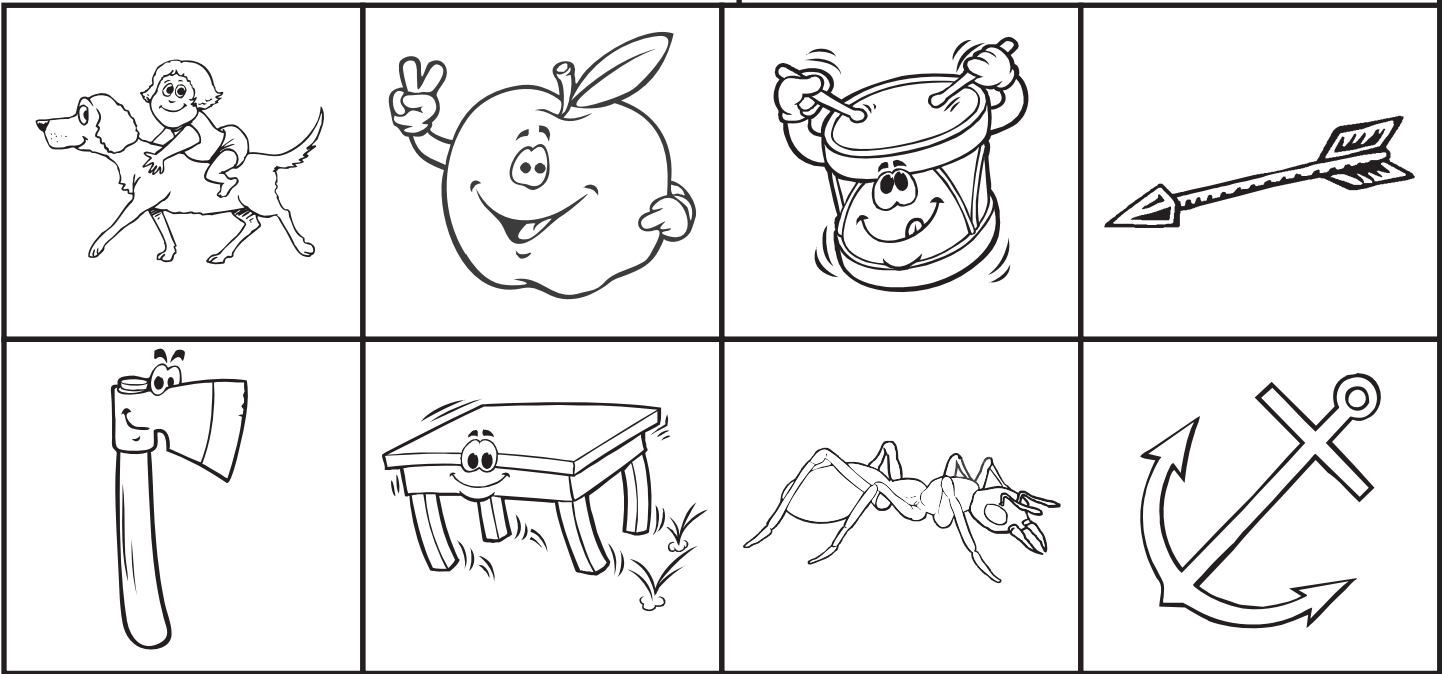

Trace the apples and draw an ant on each one.  
Read the sentence and trace the *a* sounds.

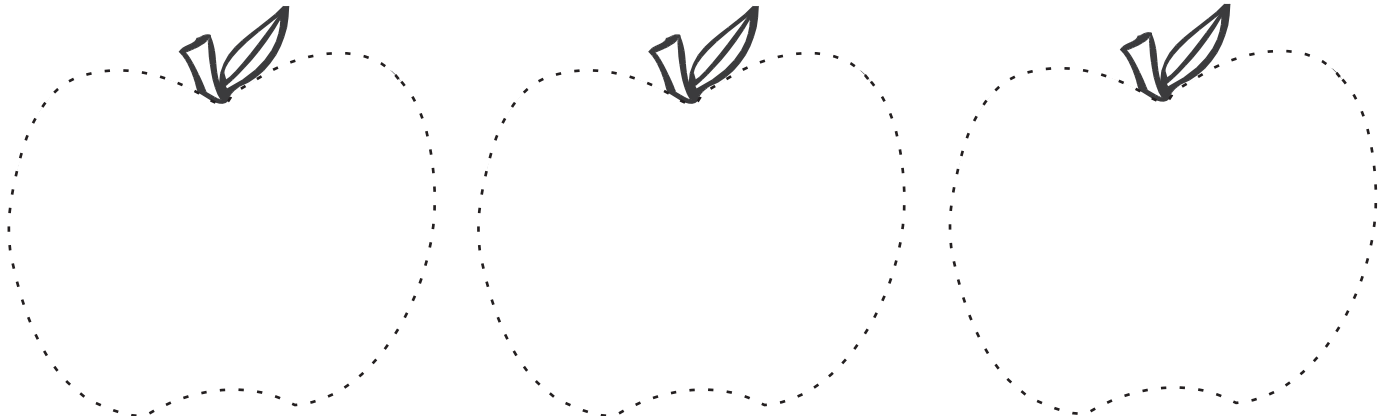

**A**nts *a*re on the *a*pples.

aA

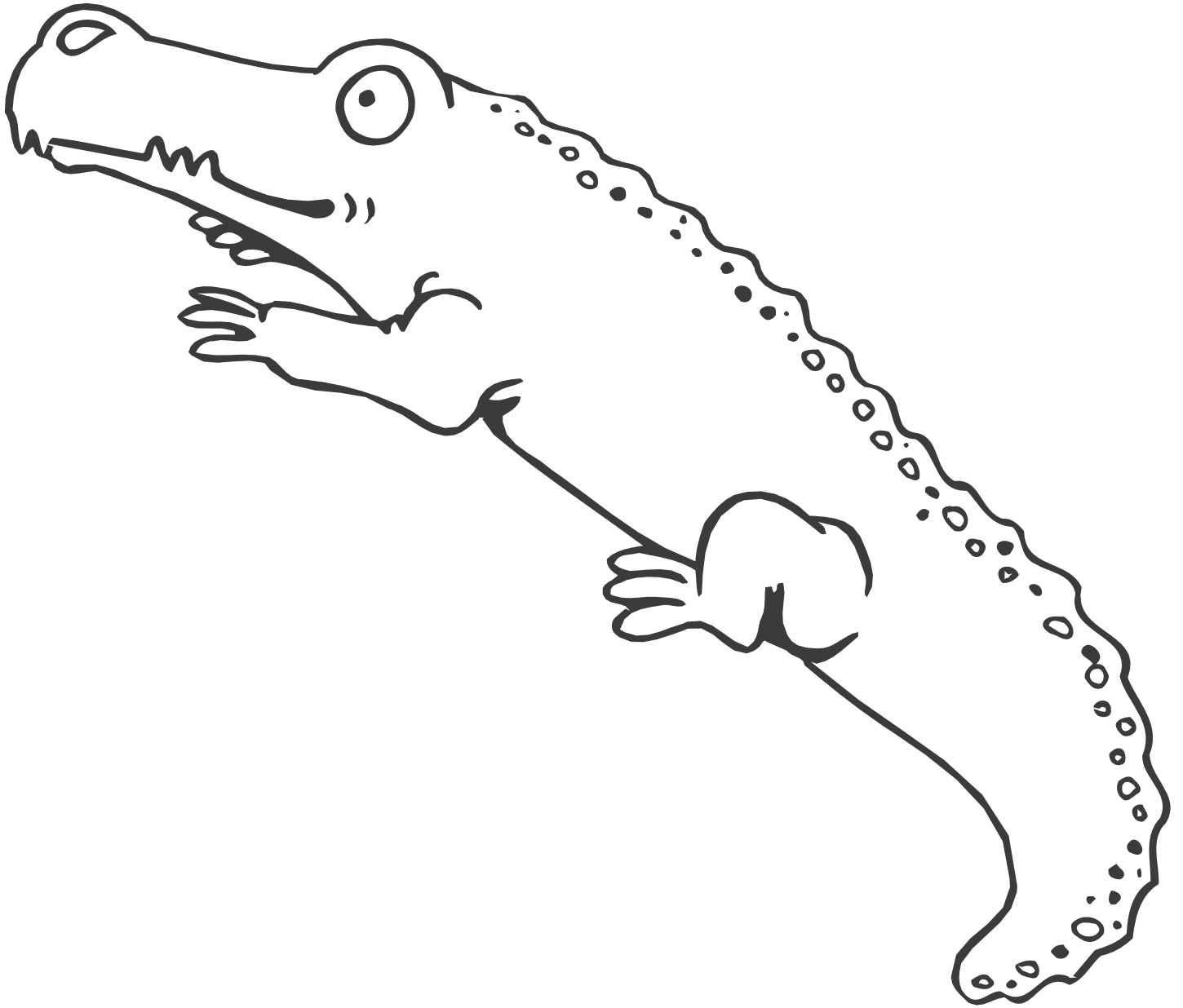

**A**ngry @nts near an @lligator.

- ☺ Colour the alligator with green and brown crayon or paint.
- ☺ While wet, use a crumpled ball of newspaper to print on the alligator.
- ☺ Dip a cotton bud in black paint and print ants around the alligator.
- ☺ Trace over the @ sounds in the sentence.

a A

1. Colour the pictures that start with a.
2. Trace the a words.



apple

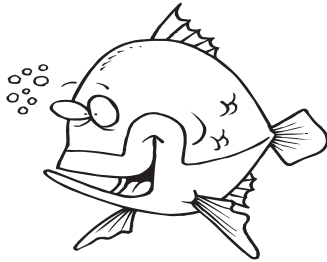

fish

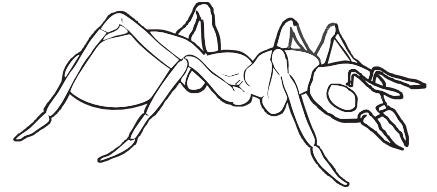

ant

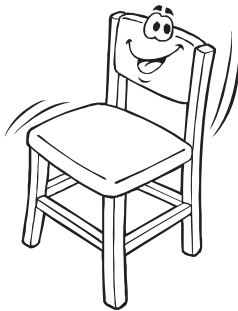

chair

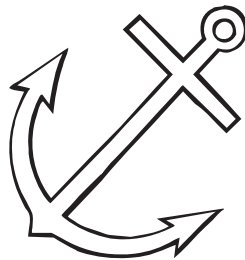

anchor



alligator

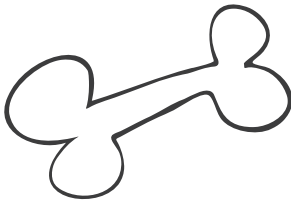

bone



ambulance



bird

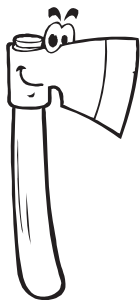

axe



cup

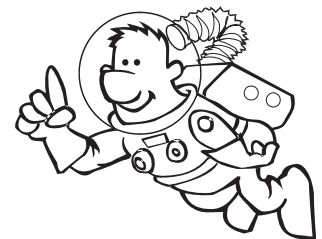

astronaut

Write some a words on another sheet  
or find some a pictures in magazines or newspapers.



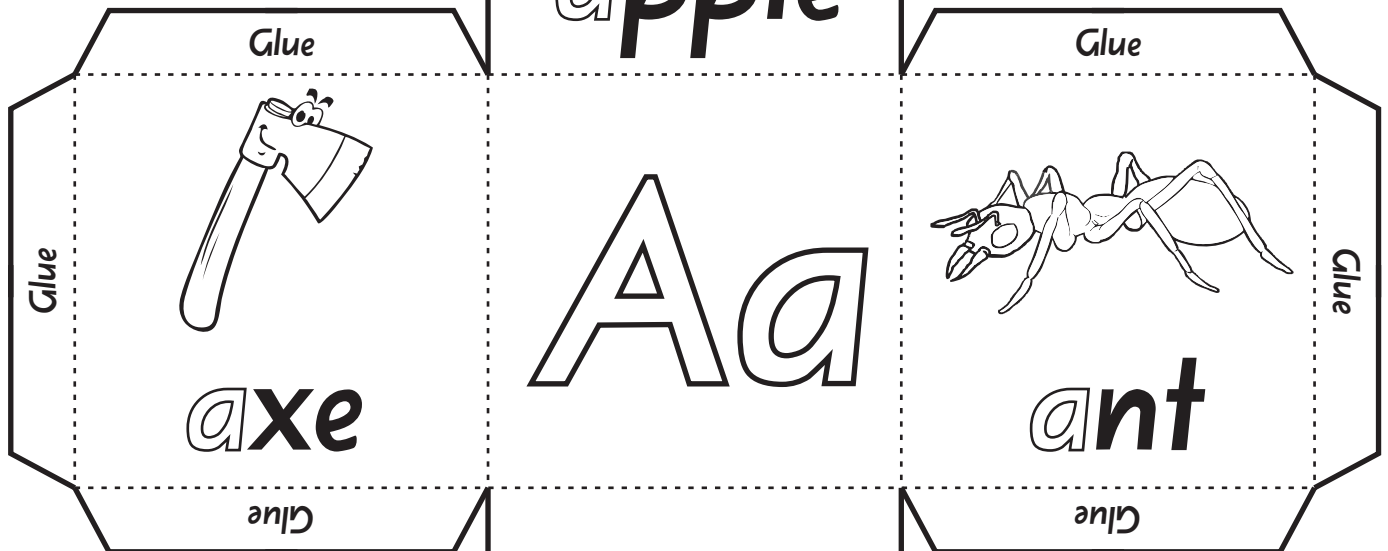
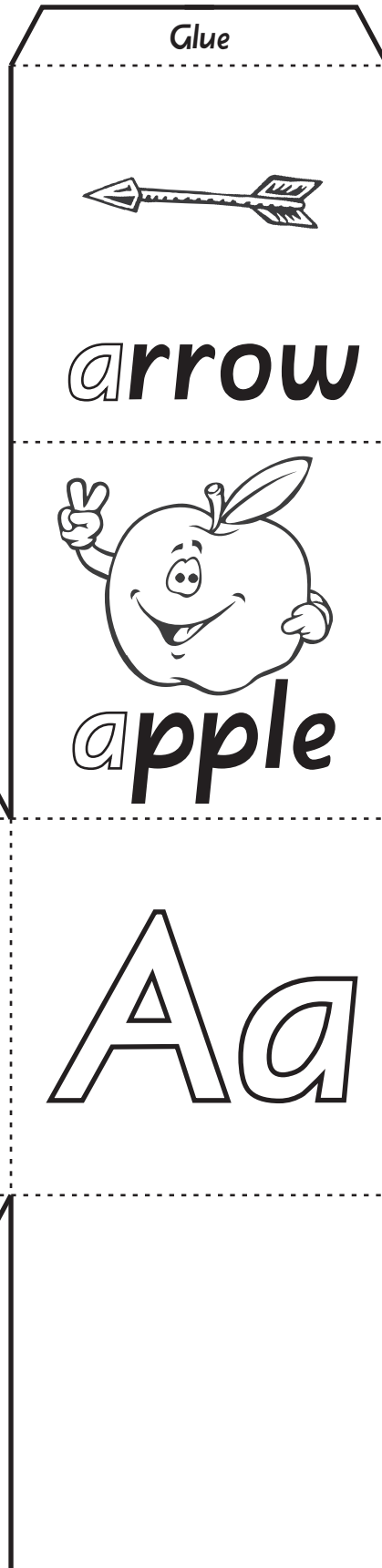
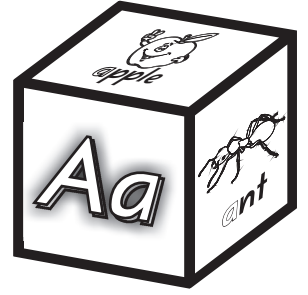

Colour in the big *Aa* sounds.



Colour the *a* pictures.



Trace over the *a* sounds in the words.



Draw your own *a* picture in the blank square.

Cut along the straight lines and fold along the dotted lines. Glue it together to make a cube.

Trace any @ sounds. Colour any picture that starts with @.

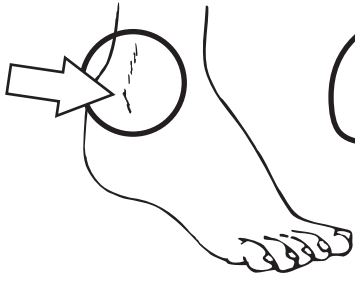

a

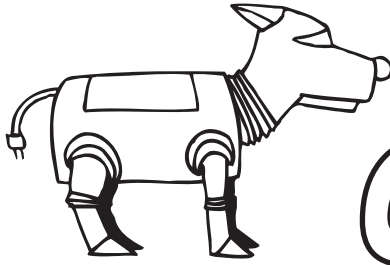

d

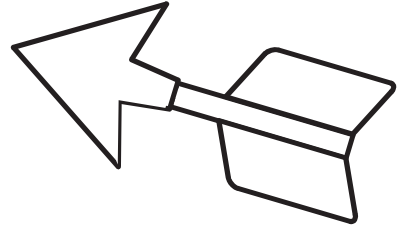

a

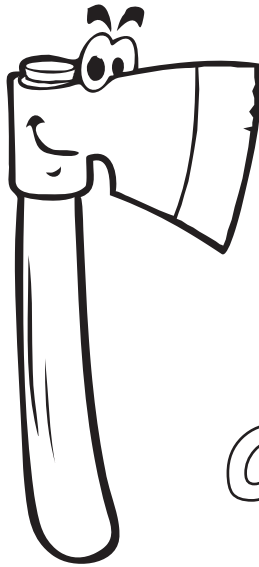
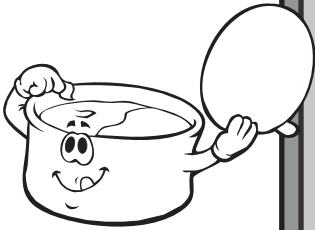

a

axe

o

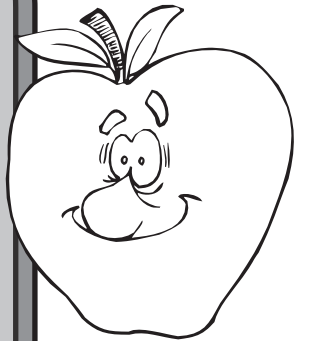

a

Draw your own @ picture.

a

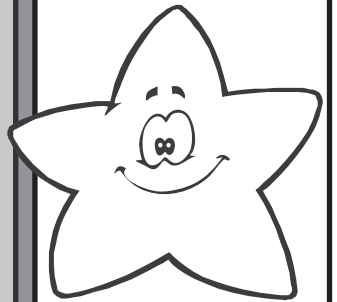
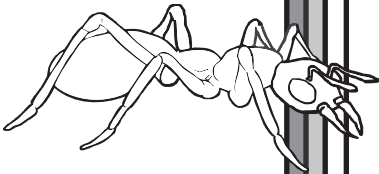

a

e



a

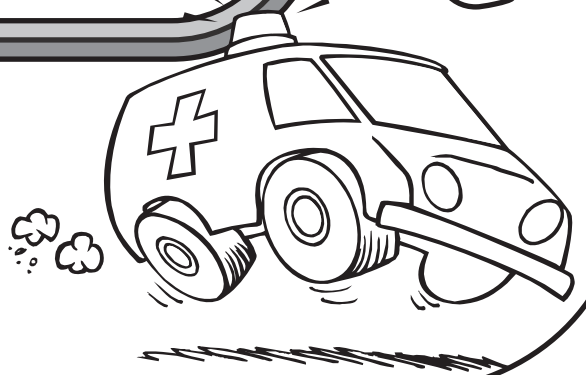
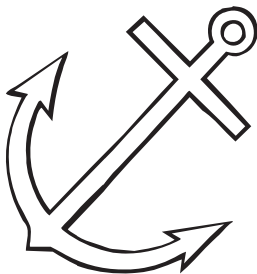

Draw a line to match the picture and word. Write the sound.



stronaut

a A

xe



rrow

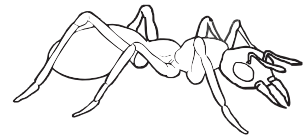

nt



pple

Circle the words that start with a.

ant dog rabbit axe at  
ambulance box am drum  
an robot actor antler

There are  a words.

Colour the pictures that start with a.

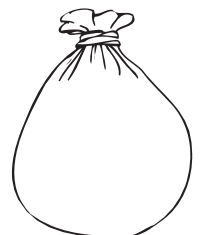
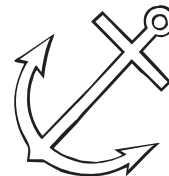
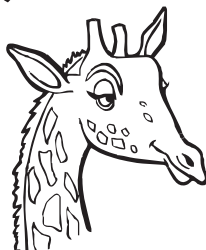
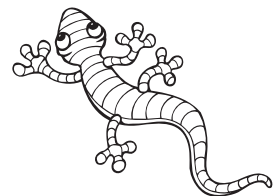
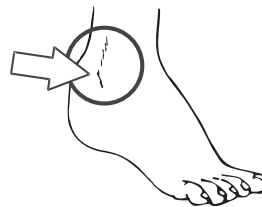
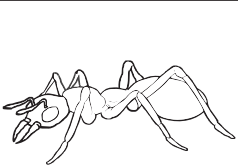

a A

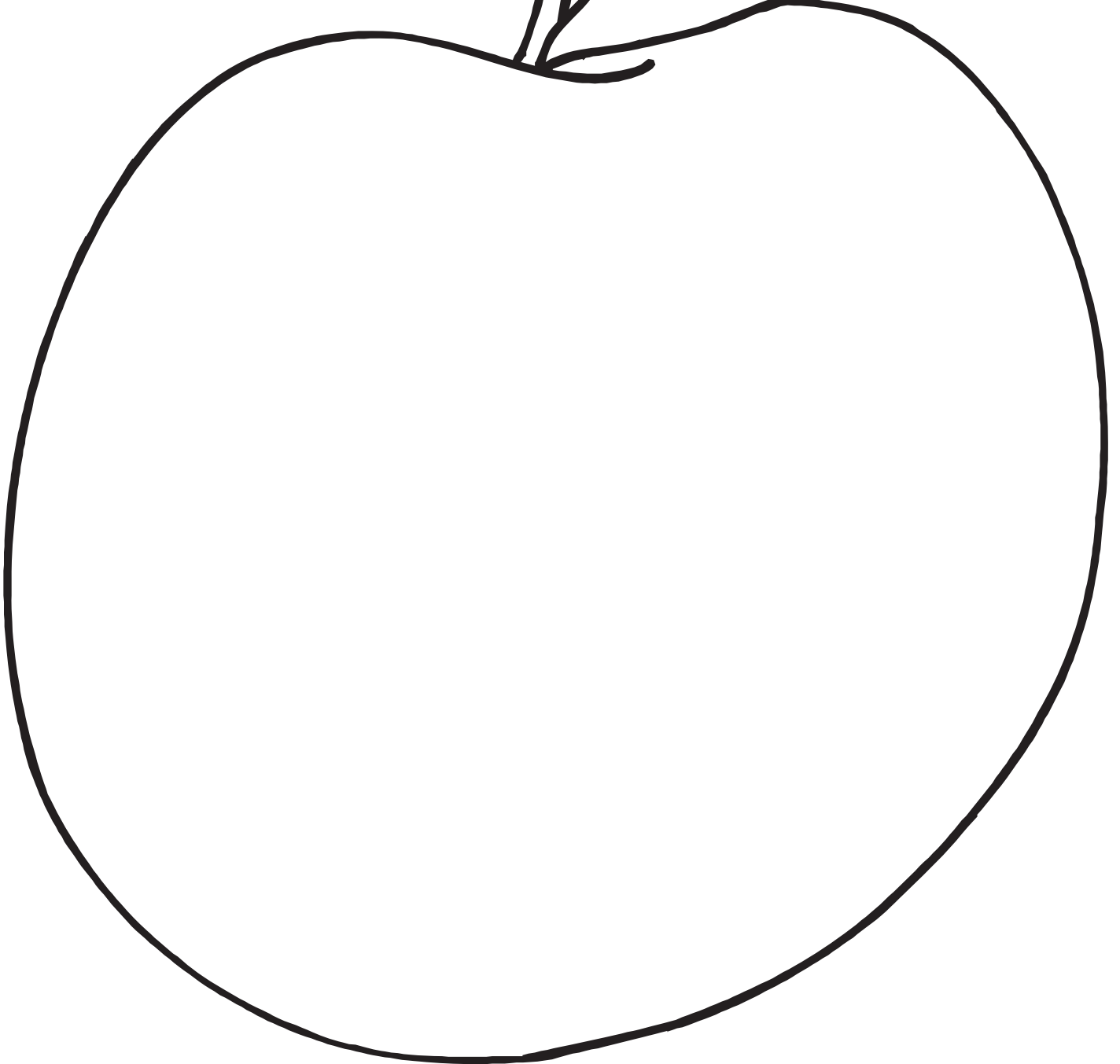

**PICK A  
CRAFT  
IDEA**



- 1** Use paper chipping to cover the apple.  
Paste these finished apples onto a large tree mural painted by the class.
- 2** Use finger painting to cover the apple then cut out @ pictures  
from magazines and paste them onto the large apple.
- 3** Write @ words inside the large apple.  
Make a big basket using rolling or chipping and paste the finished apples inside it.



Trace the **b** sounds.

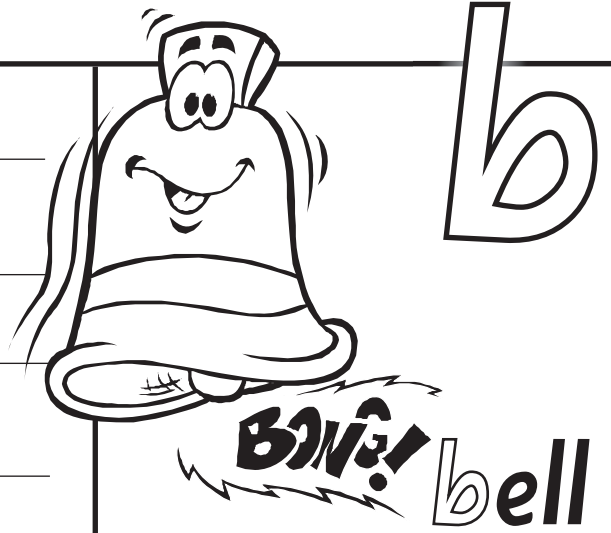
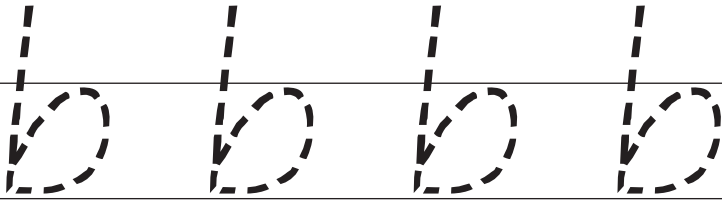

Colour the pictures that start with **b**.

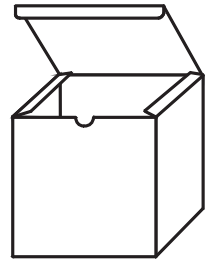
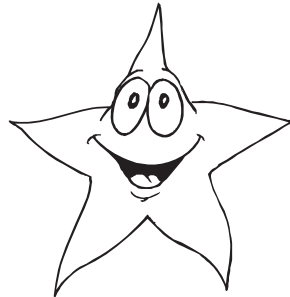
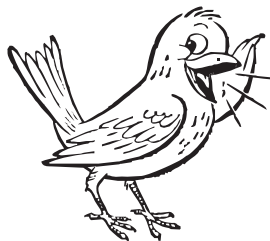
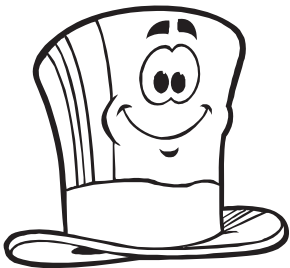
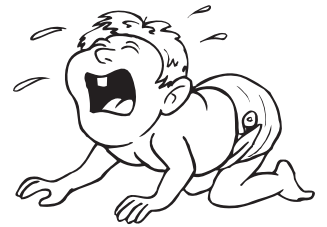
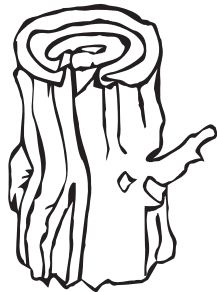
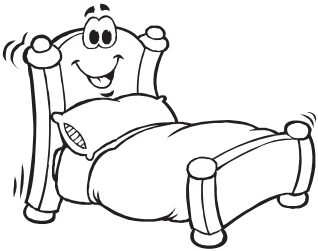

Read the sentence and trace the **b** sounds.  
Trace the butterflies and colour one blue.

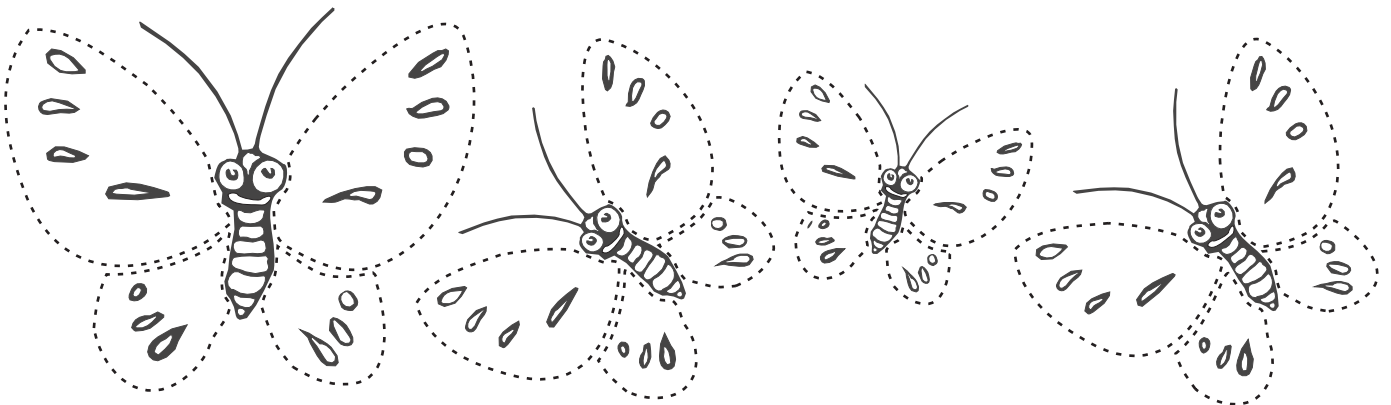



I saw a **b**ig **b**lue **b**utterfly.

b B



*The **b**aby has a **b**lue **b**ib.*

-  Colour the *baby* with crayon or pencil.
-  Draw a big blue *bib* on the *baby*.
-  Draw (or cut out pictures from a magazine) toys around the *baby* that start with **b** e.g. *bear, balloon, bell, bicycle or boat.*

# bB

1. Colour the pictures that start with **b**.
2. Trace the **b** words.



bat

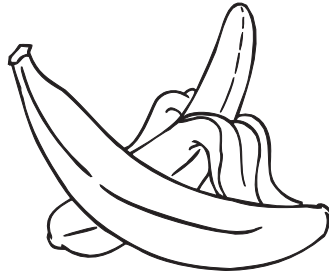

bananas

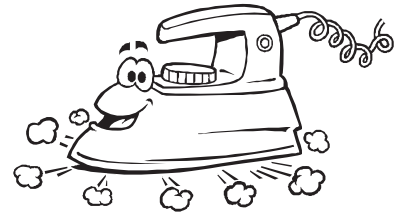

iron

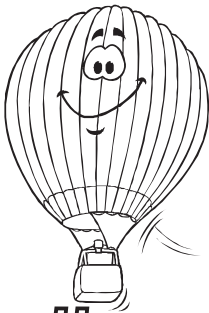

balloon



bee



flower

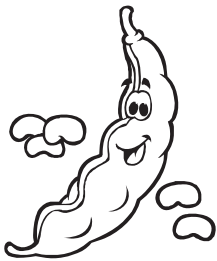

bean

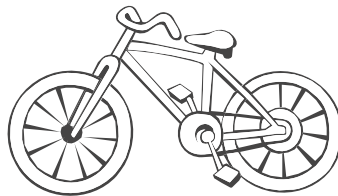

bike



bowl

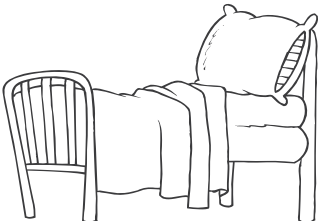

bed

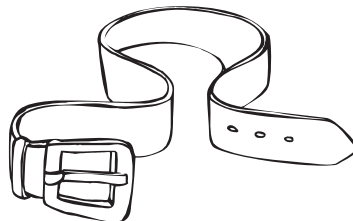

belt



fire engine

Write some **b** words on another sheet  
or find some **b** pictures in magazines or newspapers.



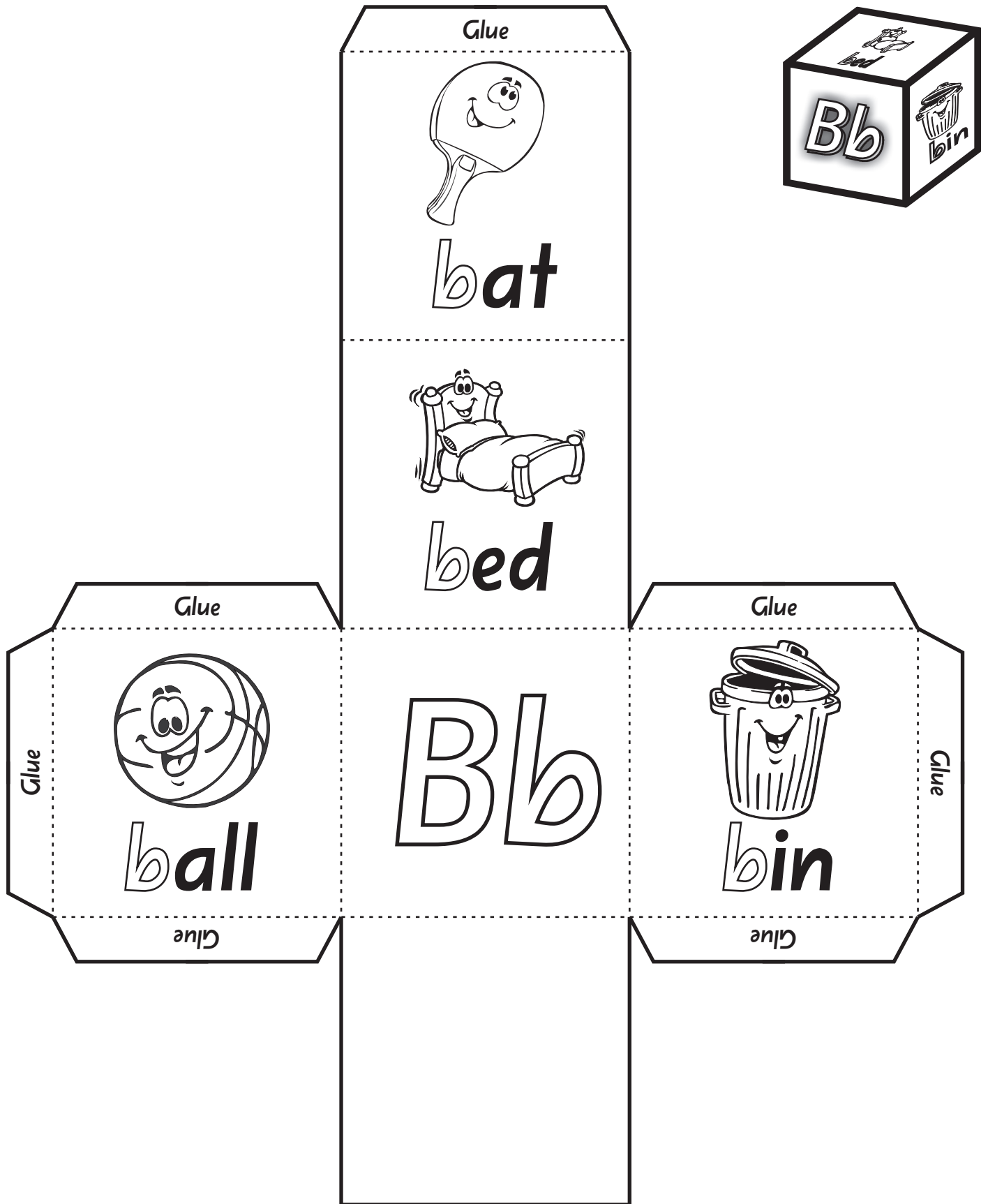

Colour in the big **Bb** sounds.



Colour the **b** pictures.



Trace over the **b** sounds in the words.



Draw your own **b** picture in the blank square.

Cut along the straight lines and fold along the dotted lines. Glue it together to make a cube.

Trace any **b** sounds. Colour any picture that starts with **b**.



b



d

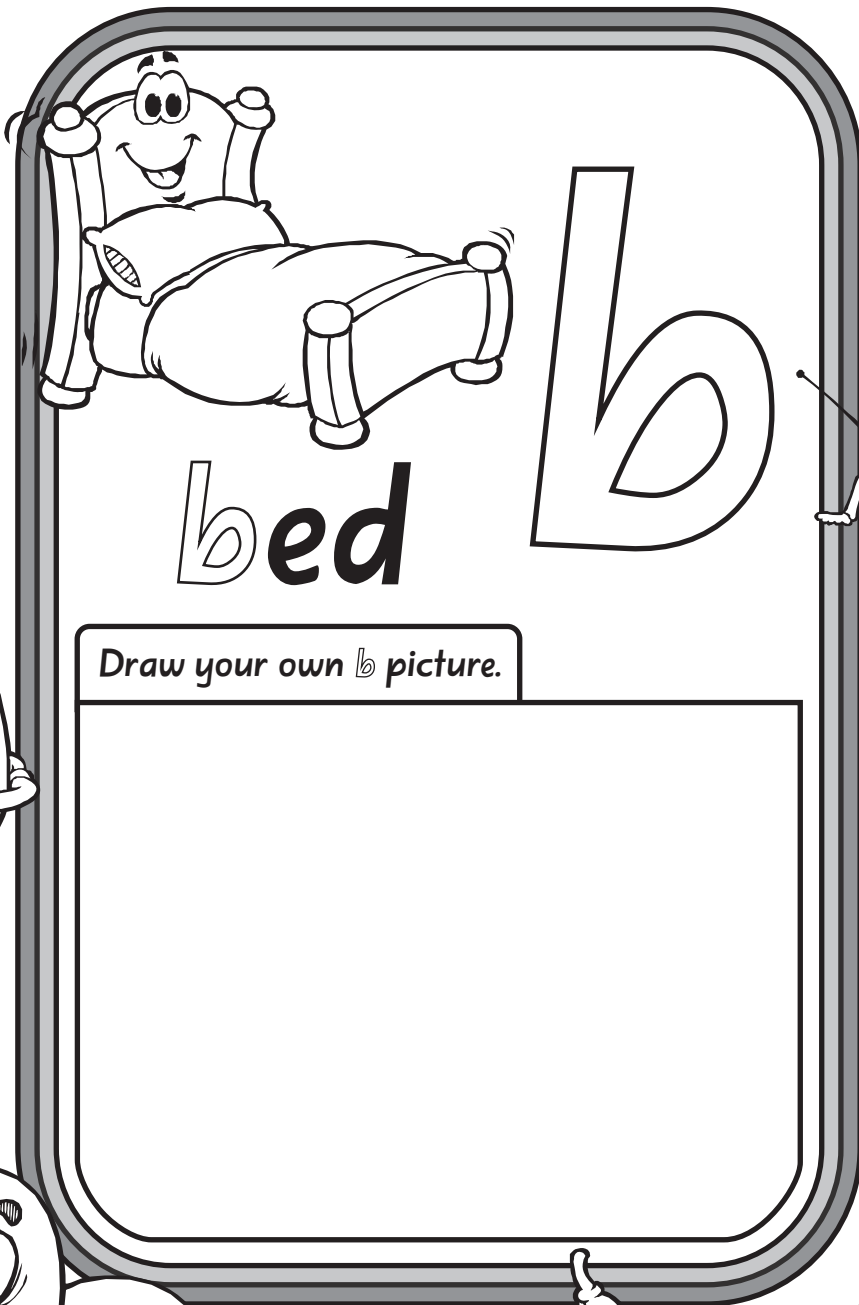
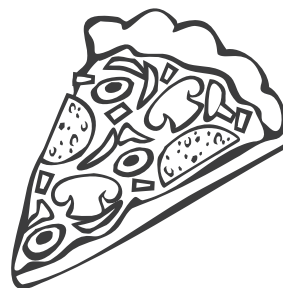

b

bed

b

b

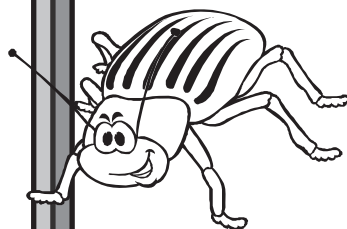

Draw your own **b** picture.

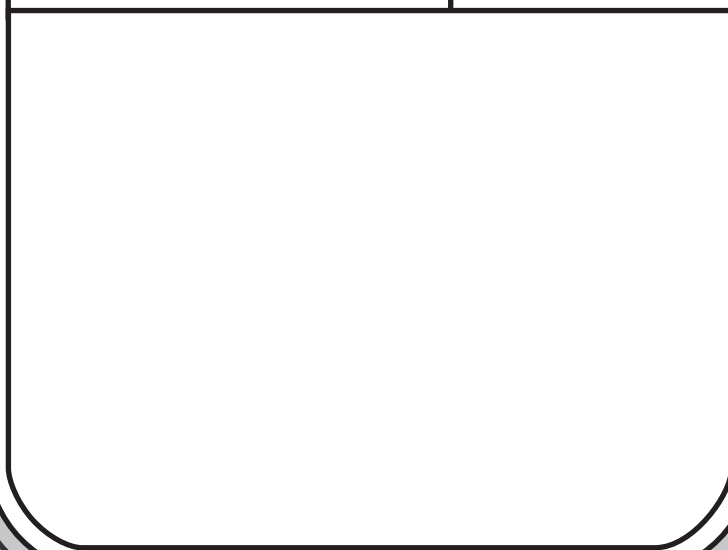

a

b

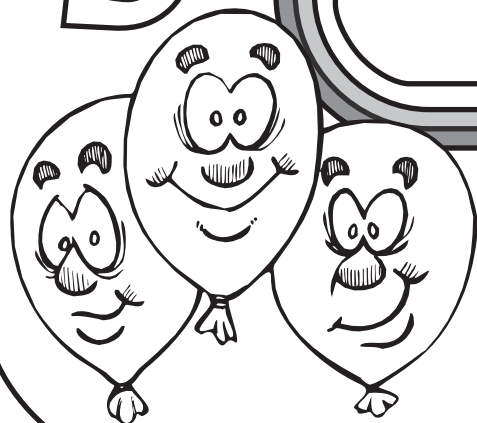
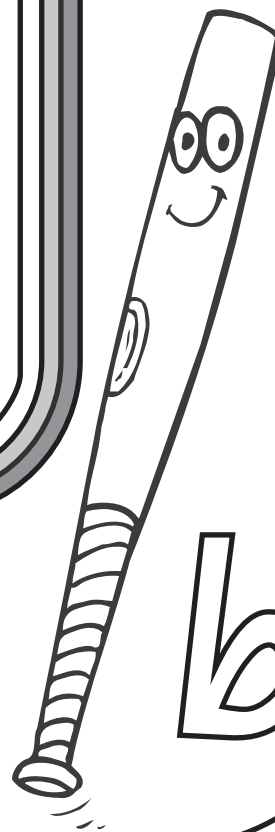

d

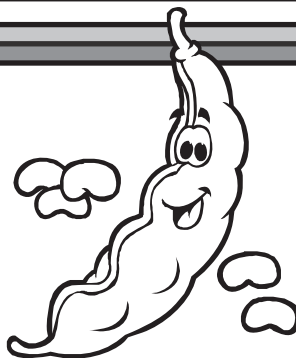

b

b B

Draw a line to match the picture and word. Write the sound.

baby

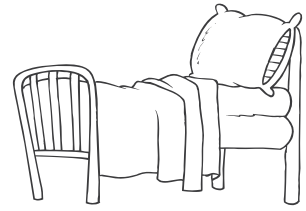

bird



bag

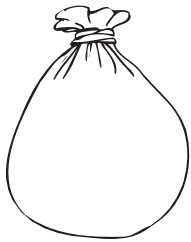

bee

bed

Circle the words that start with b.

badge basket be corn

bell rock happy book

zip ball box bug by

There are  b words.

Colour the pictures that start with b.

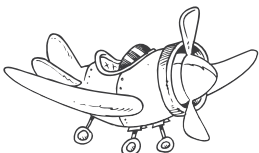
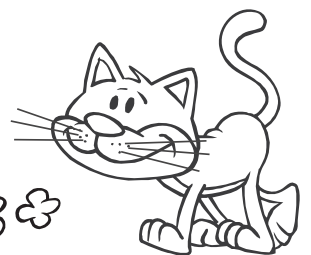
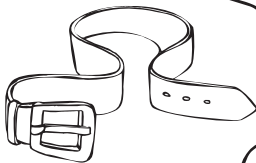
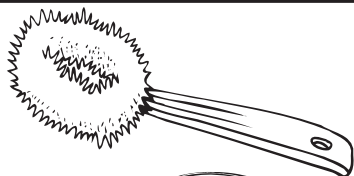

# b B

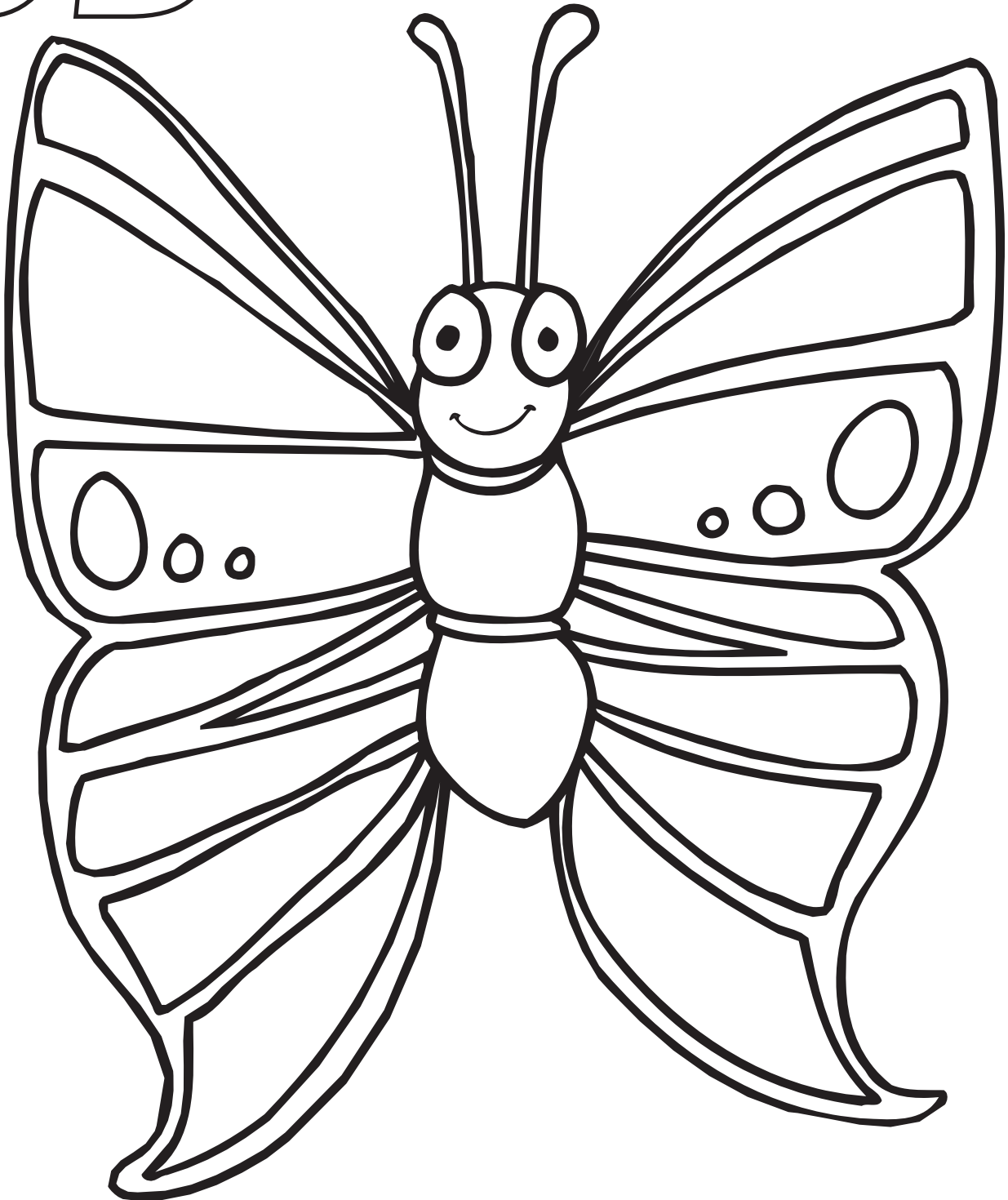

**PICK A  
CRAFT  
IDEA**



- 1** Write **b** words in some of the segments of the butterfly. Colour the remaining parts brightly.
- 2** Colour the butterfly and then make some flowers with **b** words on their petals. Mount it all on a board as a garden setting.
- 3** Cut out circles and paste them to make a caterpillar. Write **b** on these circles. Paste them into a mural with the butterflies.



Trace the c sounds.

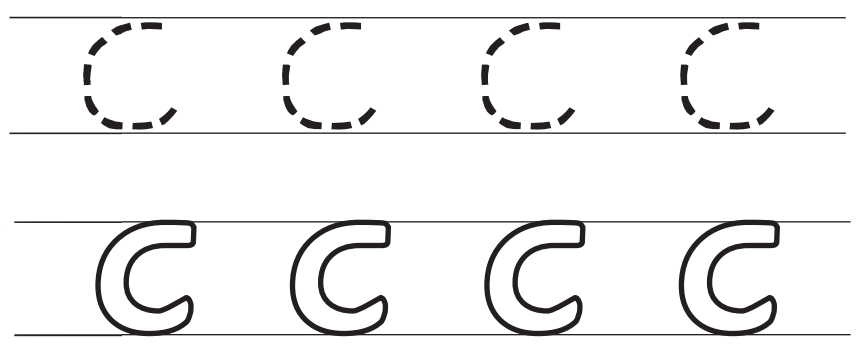
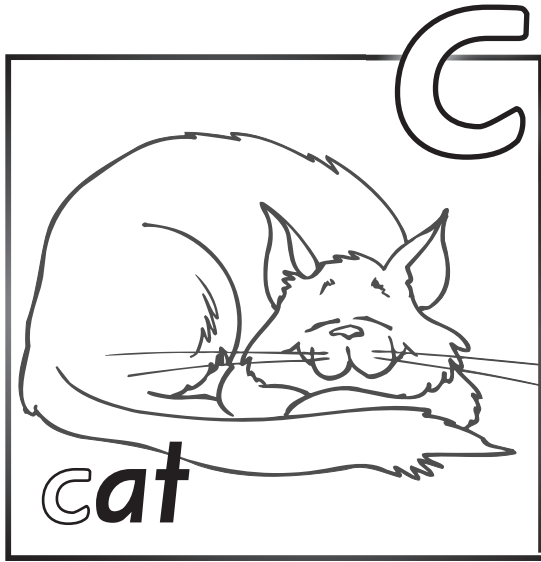

Colour the pictures that start with c.

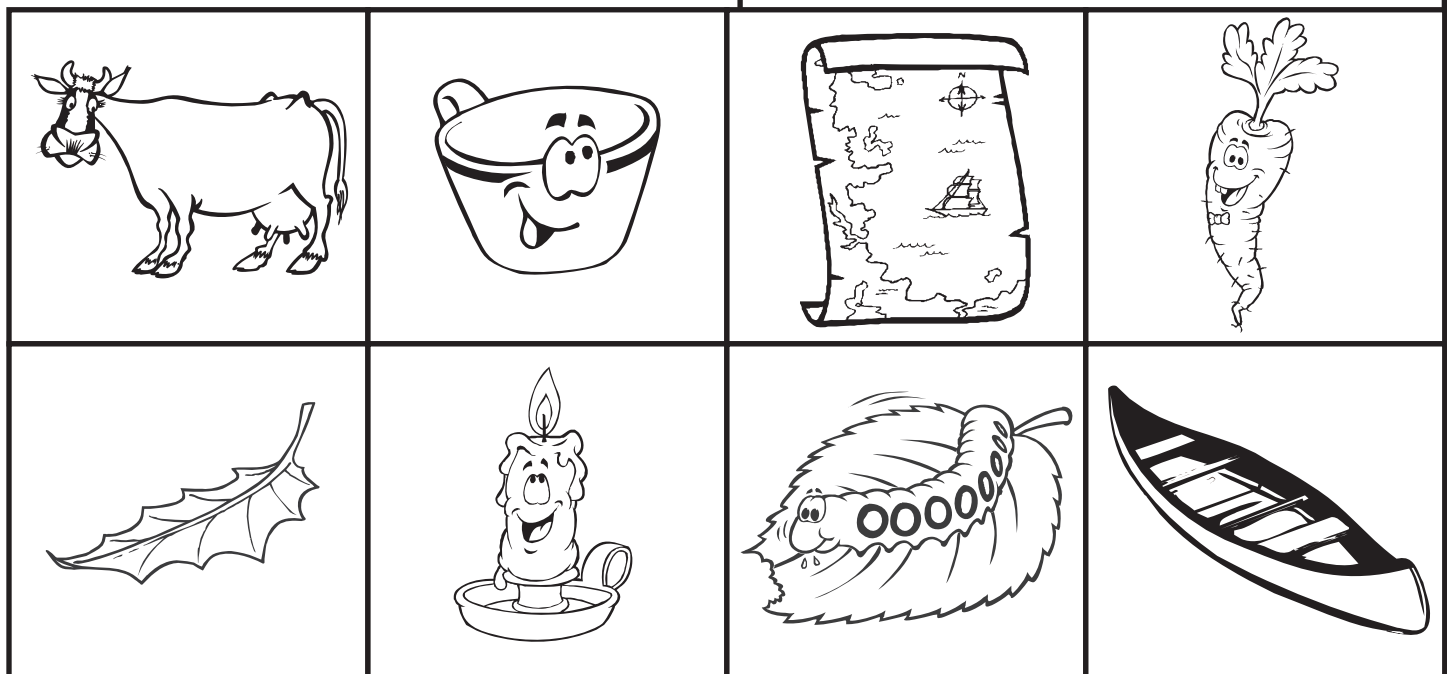

Trace the cakes and draw some candles on each one. Read the sentence and trace the c sounds.

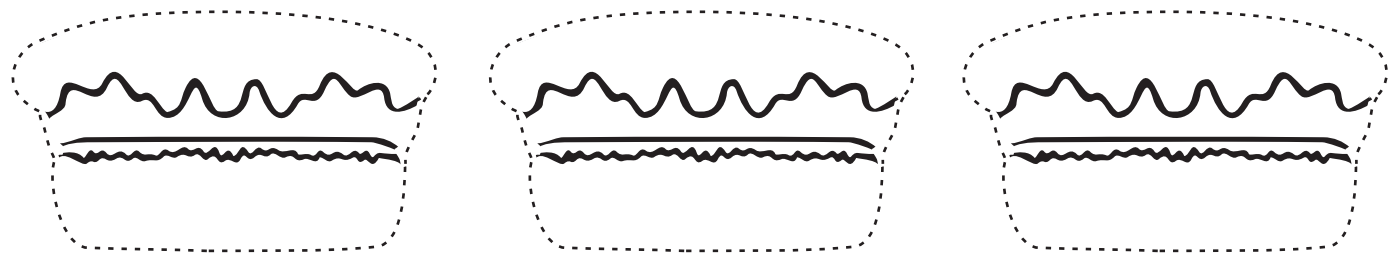

Count the candles on the cakes.



c C

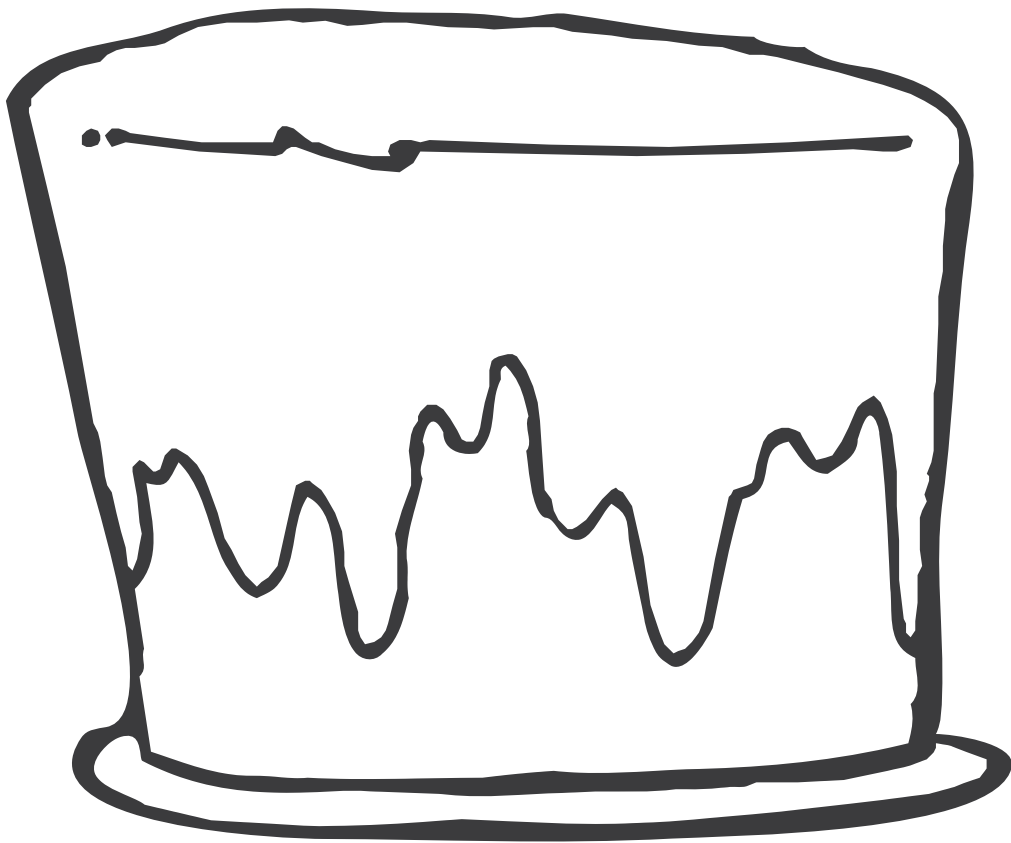

**There are .... candles on the cake.**



**Colour the cake or decorate with chips of coloured paper e.g. birthday wrapping paper.**



**Draw on candles for each child's age.**



**Trace the c sound in the sentence and write the number of candles on the cake.**

c C

1. Colour the pictures that start with c.
2. Trace the c words.

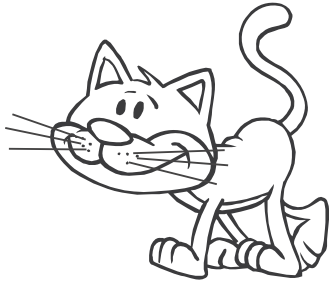

cat



newspaper

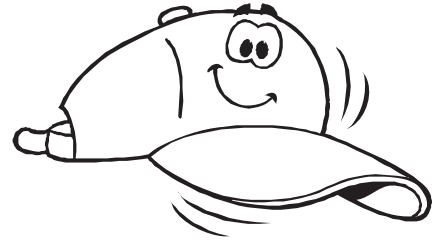

cap

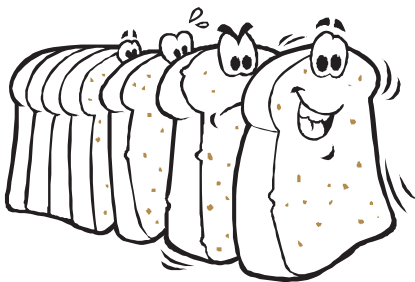

bread



cup

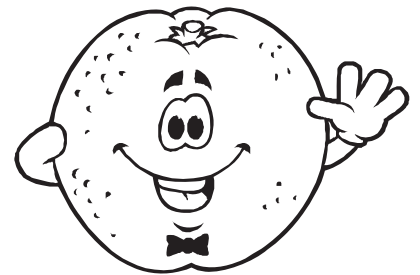

orange



bear

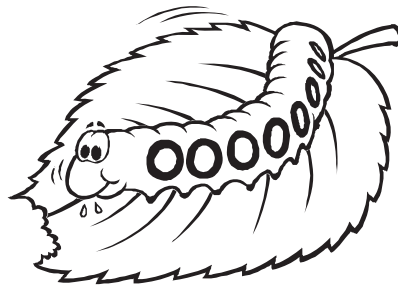

caterpillar



cans

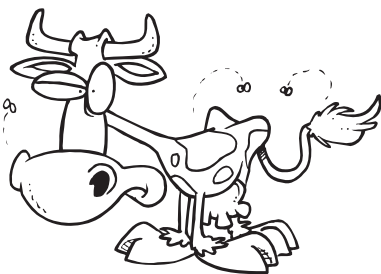

cow

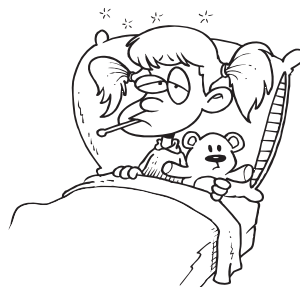

sick

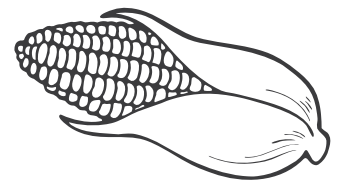

corn

Write some c words on another sheet  
or find some c pictures in magazines or newspapers.



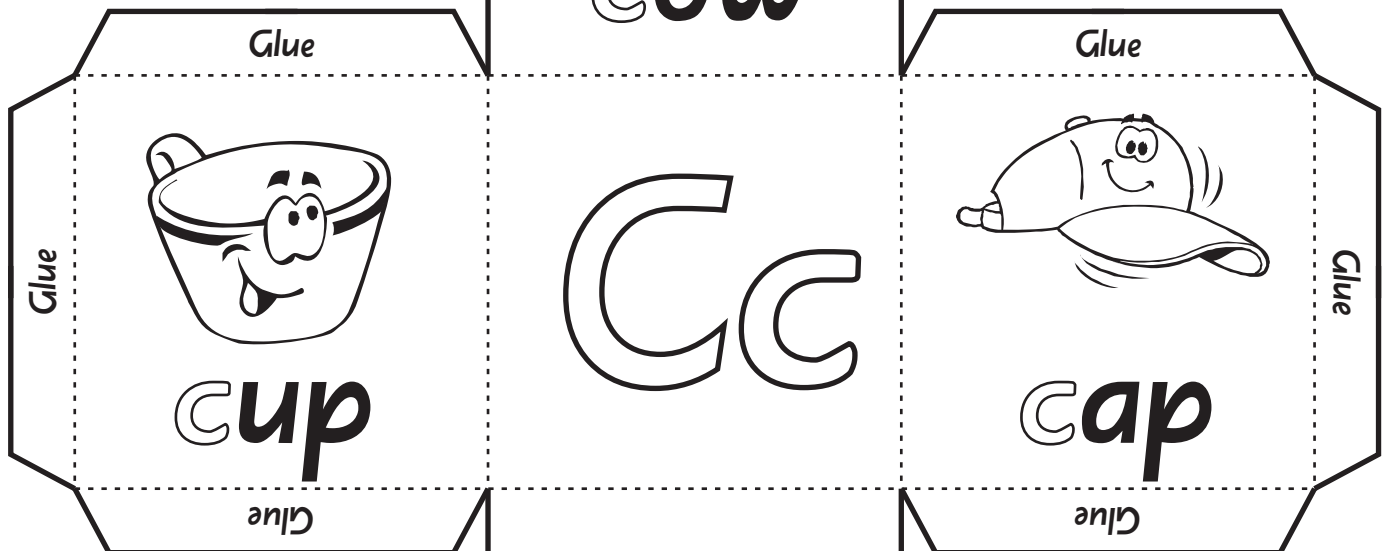
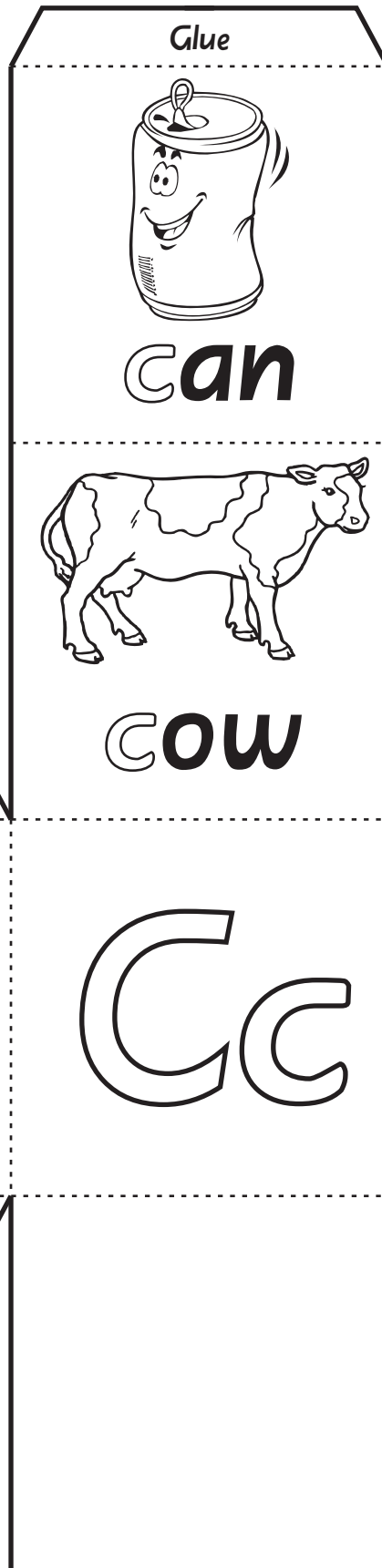
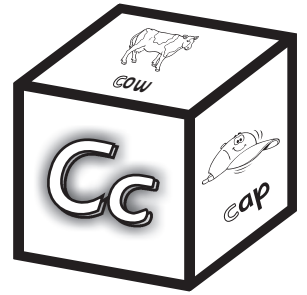

- ☺ Colour in the big Cc sounds.
- ☺ Colour the c pictures.
- ☺ Trace over the c sounds in the words.
- ☺ Draw your own c picture in the blank square.

Cut along the straight lines and fold along the dotted lines. Glue it together to make a cube.

Trace any c sounds. Colour any picture that starts with c.

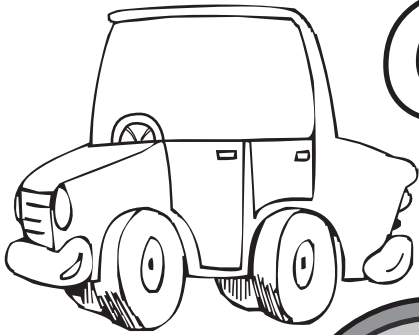

C



a



C

C

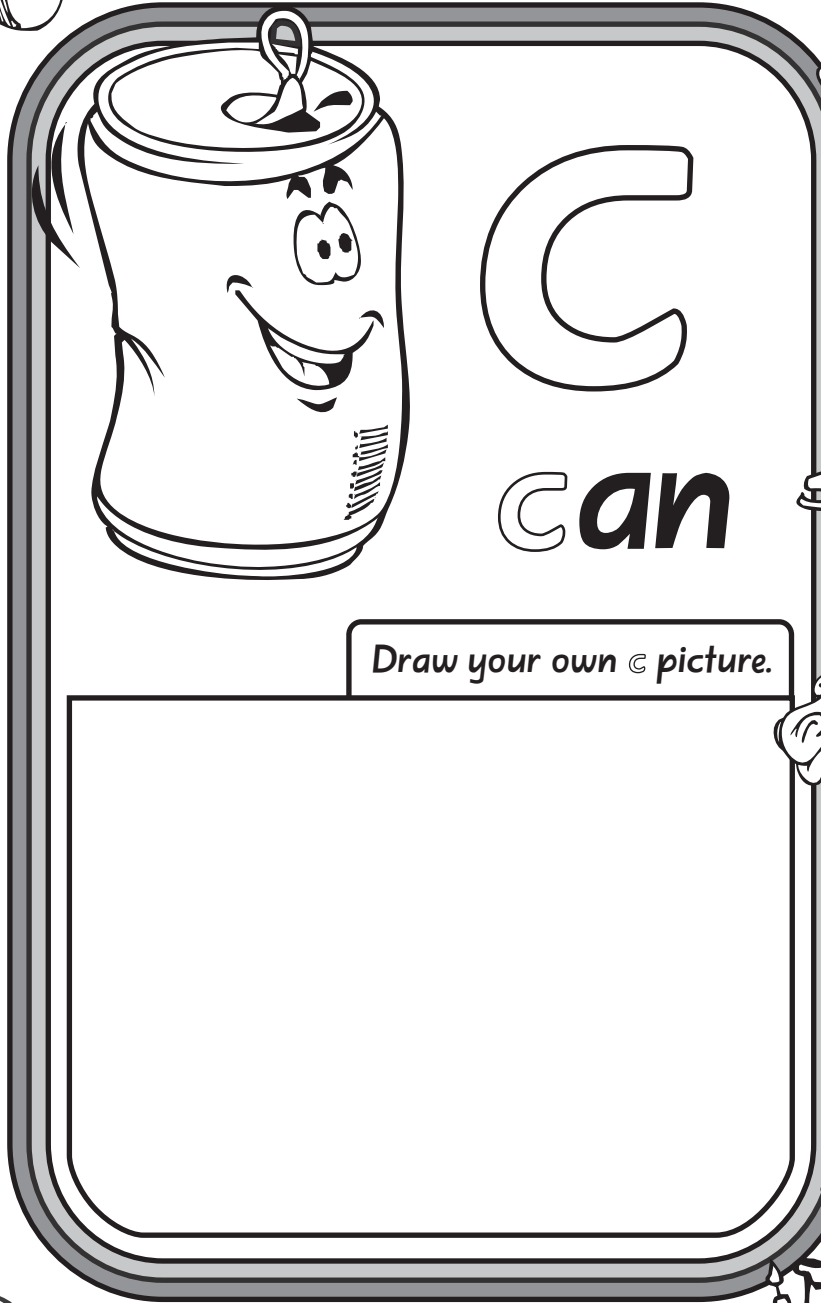
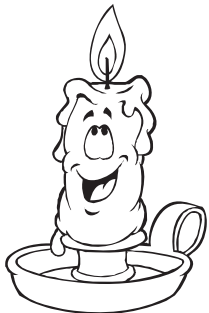

C

can

Draw your own c picture.

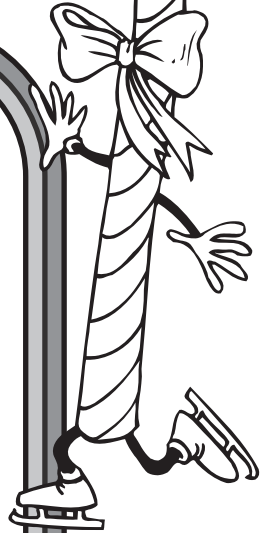

C

C

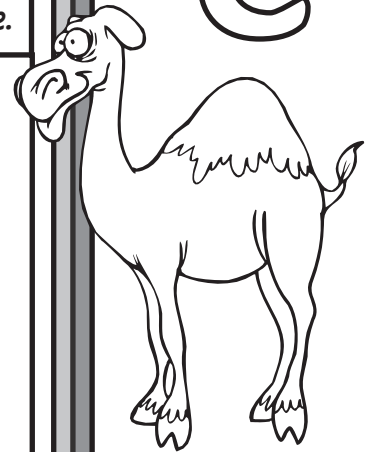

e

C

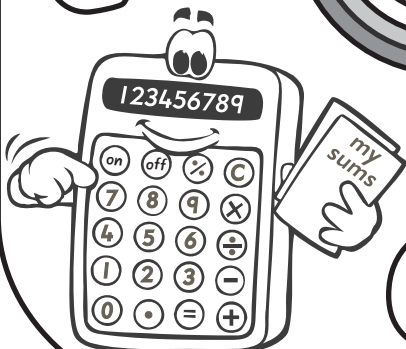

C

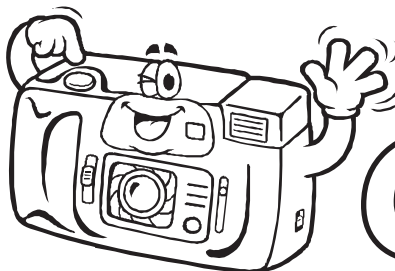

C



Draw a line to match the picture and word. Write the sound.

c c



□ an

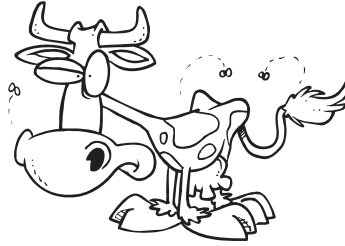

□ arrot

□ astle

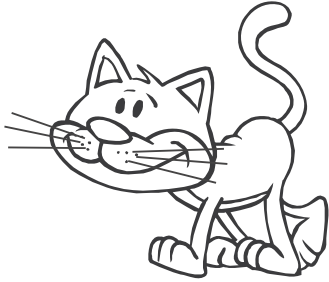

□ ow



□ at

Circle the words that start with c.

car

cast

dog

camel

boat

cake

catch

gate

come

case

in

cane

There are  c words.

Colour the pictures that start with c.

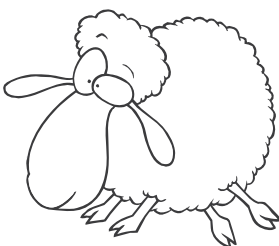
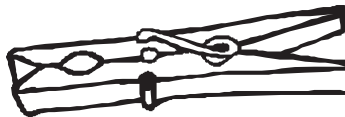

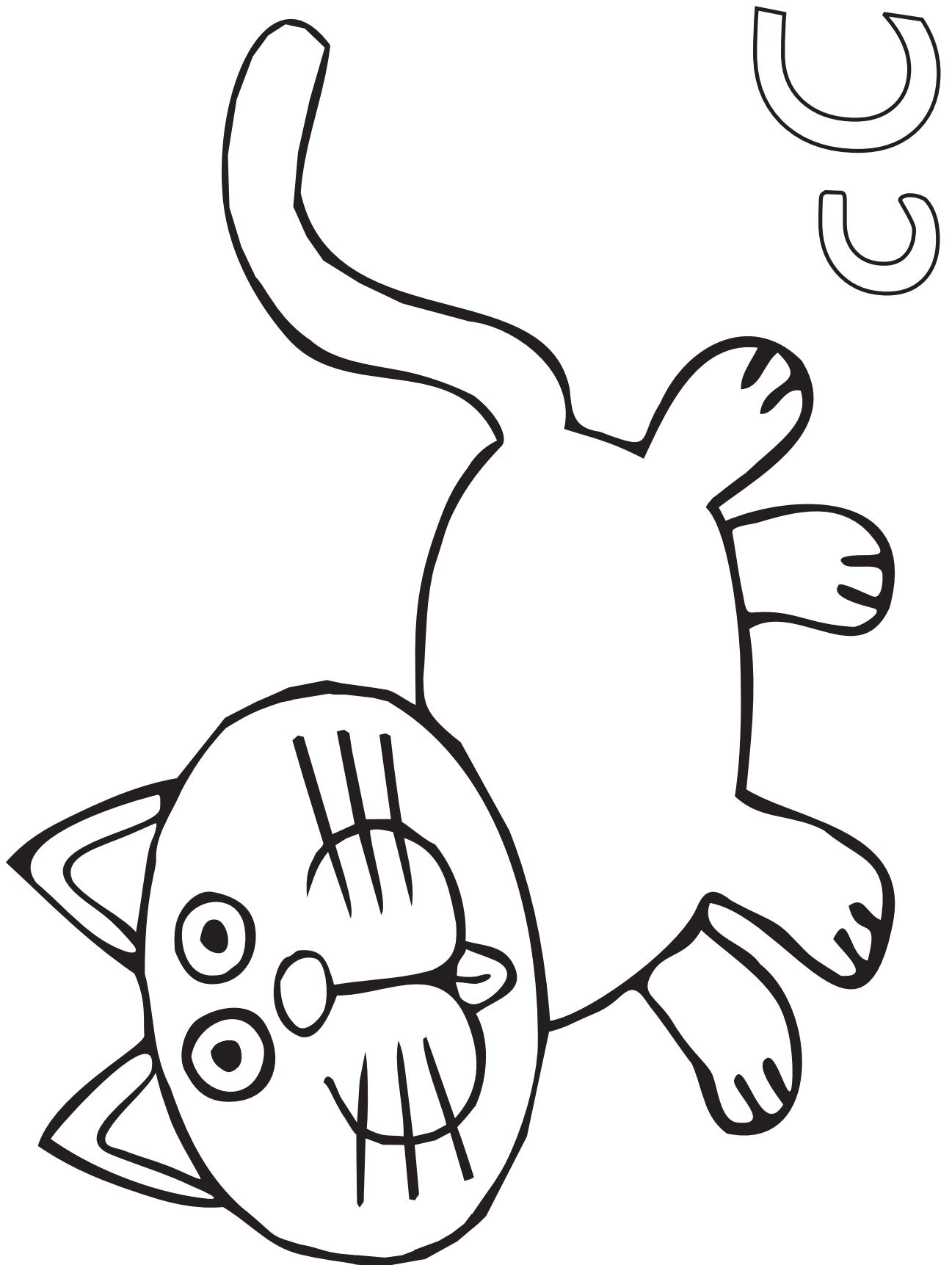

**PICK A  
CRAFT  
IDEA**



- 1** Use ripped paper pieces to paste onto the cat.  
Paint stripes on some art paper to make a mat and then glue the cat on the mat.
- 2** Use crumpled newspaper dipped in paint to print on the cat.  
Write 'c' words around the cat.
- 3** Cover the cat completely with the letter 'c' in different colours  
to create an individual looking 'c' cat.

Trace the *d* sounds.

d d d d

d d d d

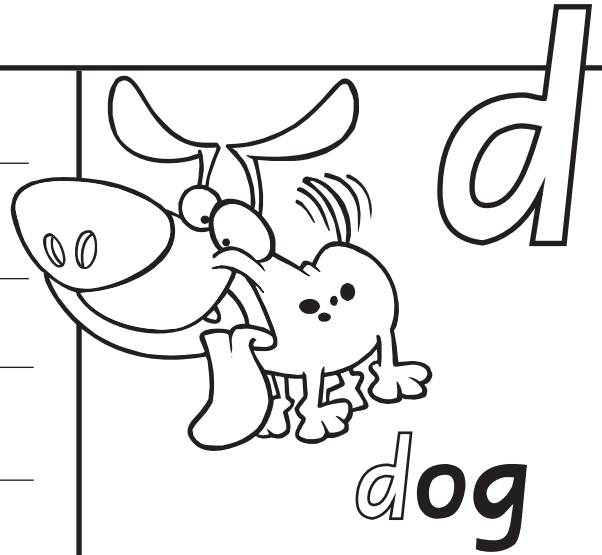

Colour the pictures that start with *d*.

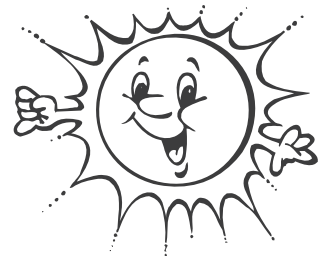
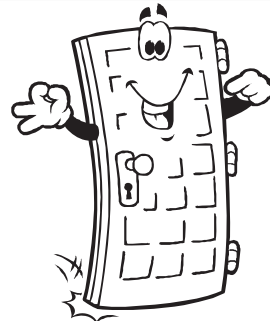
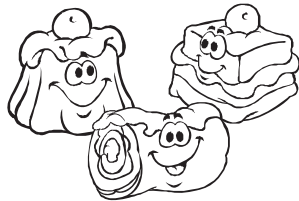
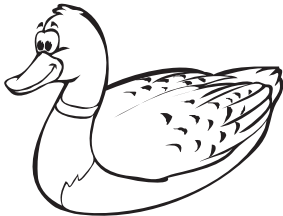
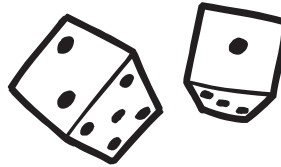
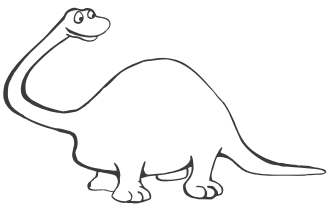

Trace the dogs. Draw some dots on each dog.  
Read the sentence and trace the *d* sounds.

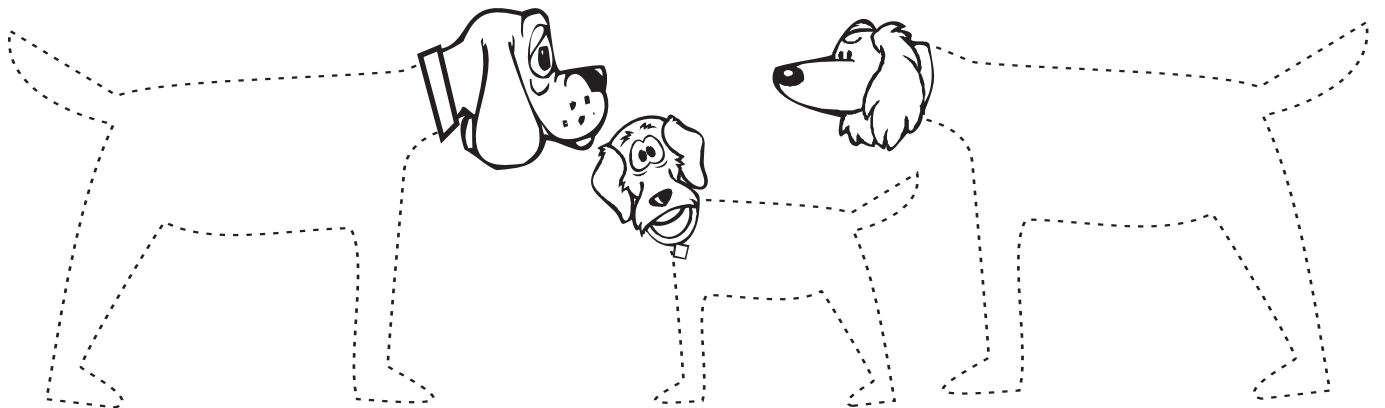

**The *d* dogs have lots of *d* dots.**



dD

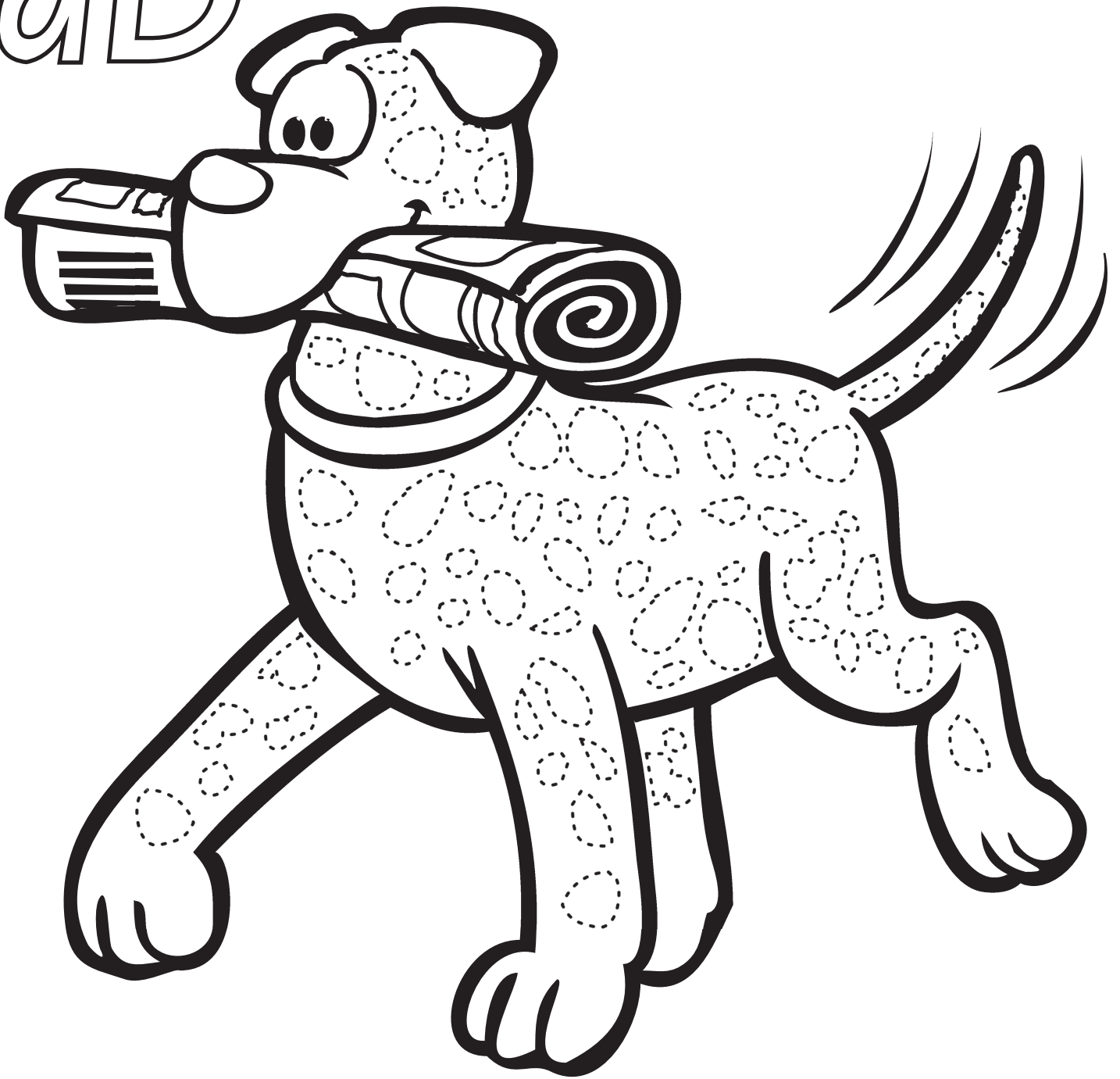

**My *d*og *D*an has lots of *d*ots.**

- ☺ Trace over the spots on the dog and colour them black or brown.
- ☺ Colour in the rest of the dog in a lighter colour.
- ☺ Trace over the *d* sounds in the sentence.



# dD

1. Colour the pictures that start with *d*.
2. Trace the *d* words.

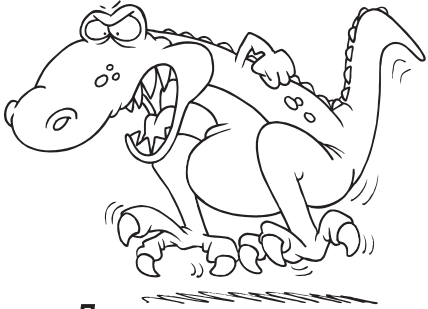

dinosaur

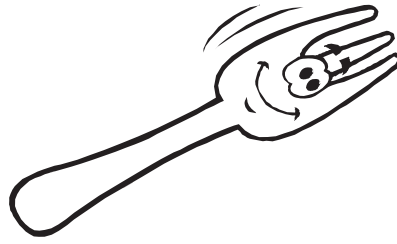

fork

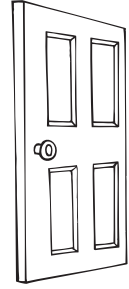

door

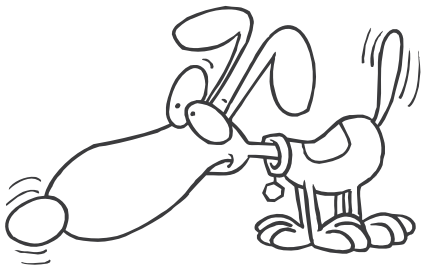

dog



snake

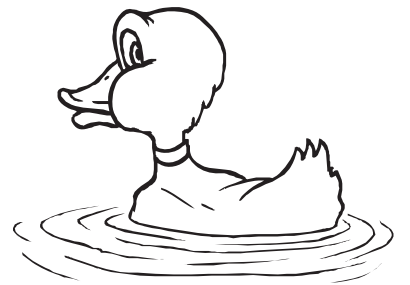

duck



dad



dance

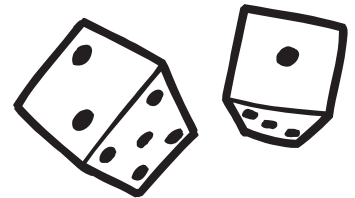

dice

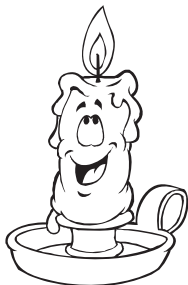

candle



dive

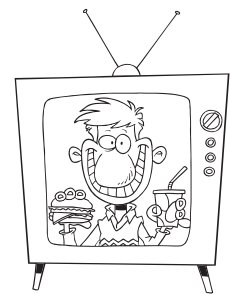

TV

Write some *d* words on another sheet  
or find some *d* pictures in magazines or newspapers.

EXTRA  
STUFF



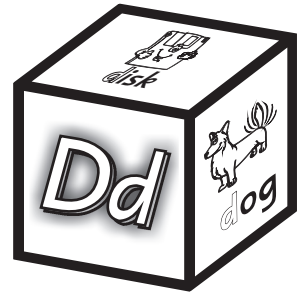

Glue

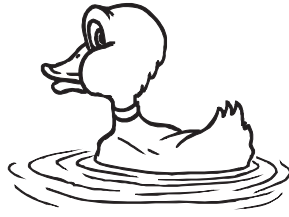

duck

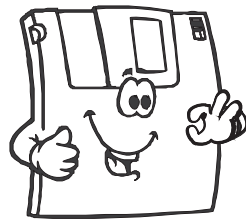

disk

Glue

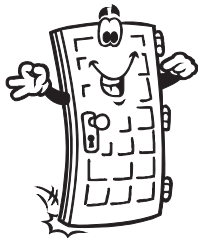

door

Glue

Glue

Dd

Glue

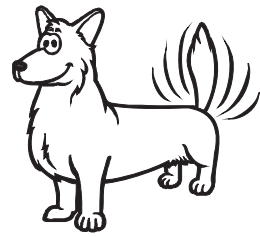

dog

Glue

Glue



Colour in the big *Dd* sounds.



Colour the *d* pictures.



Trace over the *d* sounds in the words.



Draw your own *d* picture in the blank square.

Cut along the straight lines and fold along the dotted lines. Glue it together to make a cube.

Trace any *d* sounds. Colour any picture that starts with *d*.

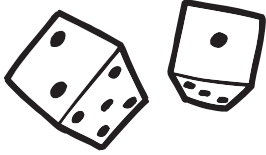

d

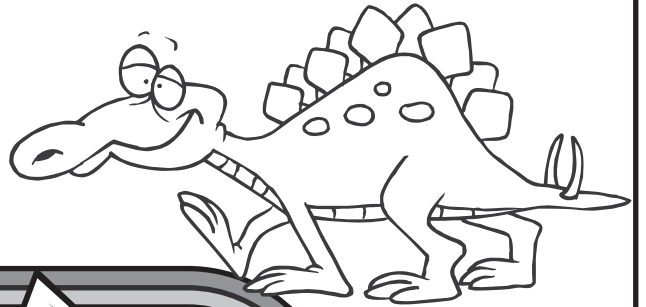
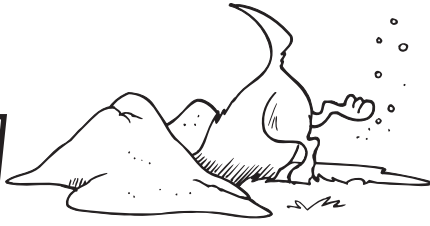

d



d

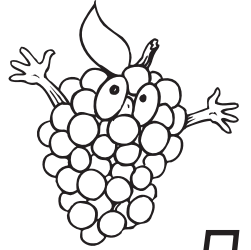

a

doll

Draw your own *d* picture.

d

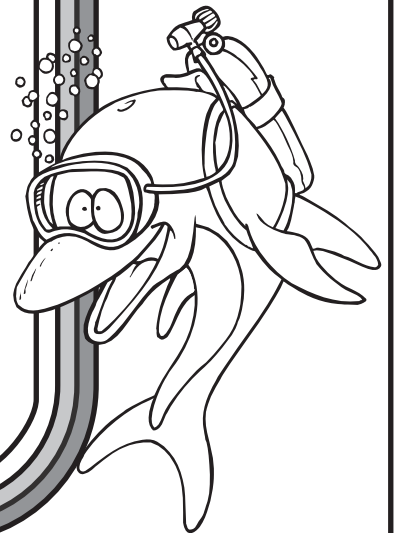

d



d

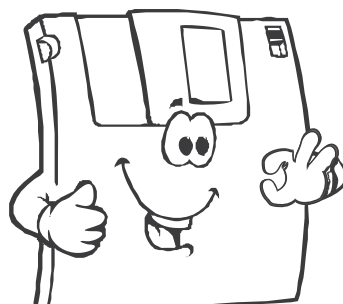

b

d D

Draw a line to match the picture and word. Write the sound.

oll



ice

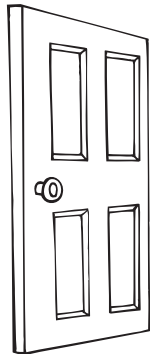

og

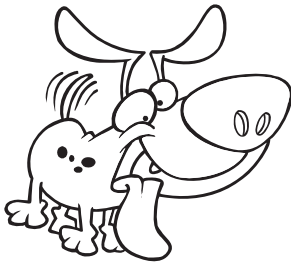
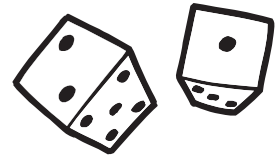

esk

oor

Circle the words that start with d.

doctor

dump

soot

dirt

bed

hen

dish

dip

den

deck

bat

dot

kit

dart

There are  d words.

Colour the pictures that start with d.

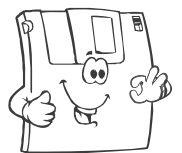
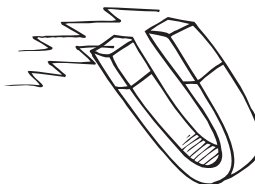
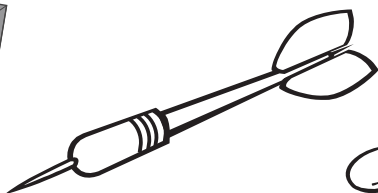
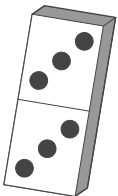

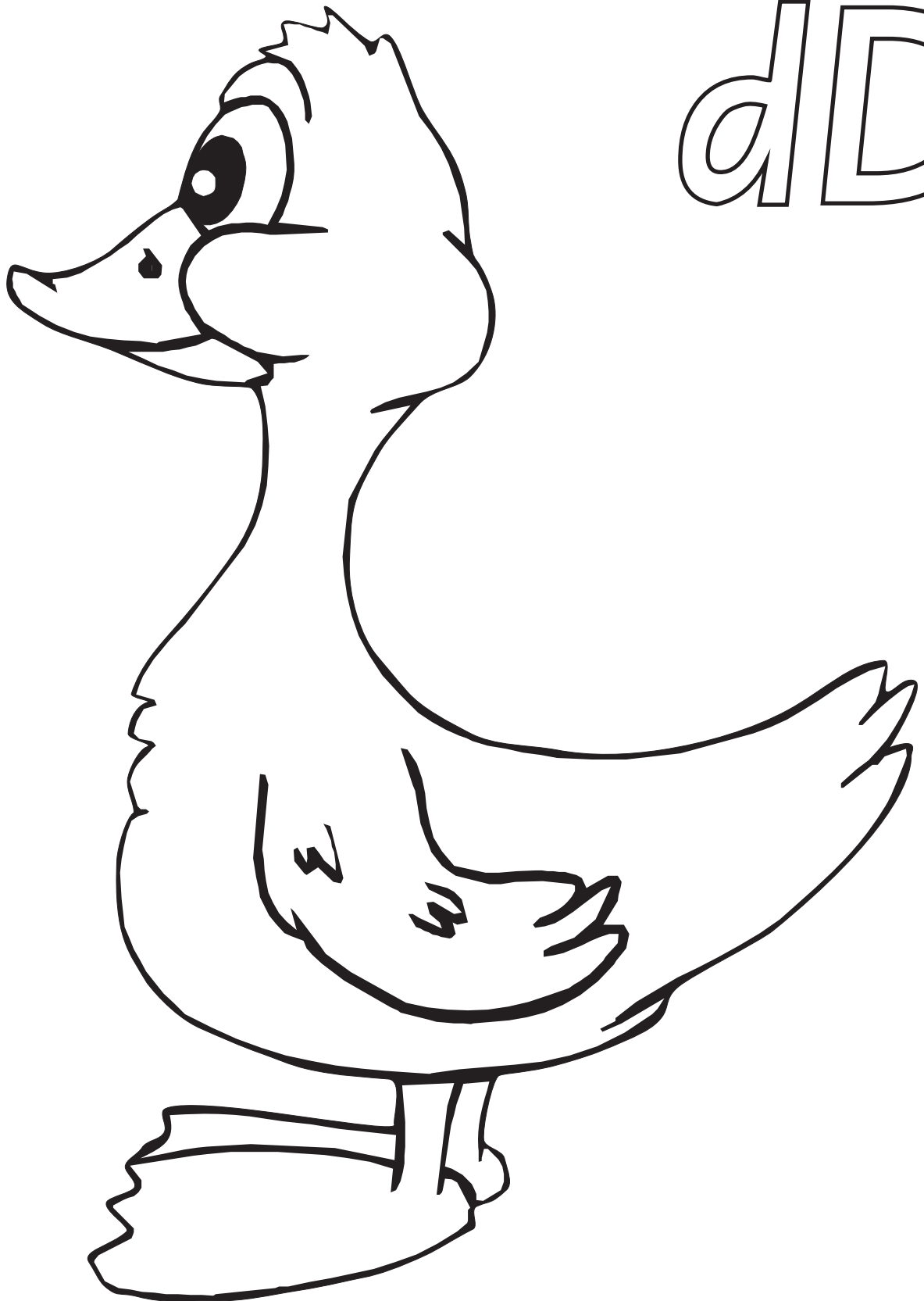

dD

PICK A  
CRAFT  
IDEA



- 1** Tuft yellow crepe paper and paste it on the duck. Paint large sheets of paper blue to make a pond. Paste the ducks on the pond. Add reeds etc.
- 2** Paint the duck yellow and the background blue. Write *d* words on small pieces of white paper and paste these on the water around the duck.
- 3** Use curled, yellow paper or cotton wool which has been sprayed with yellow paint to cover the duck.

Trace the @ sounds.

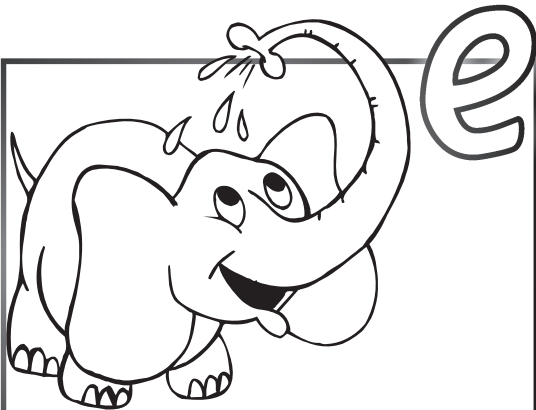

@elephant

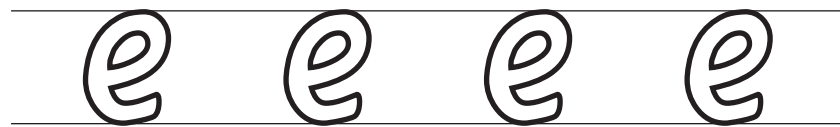

Colour the pictures that start with @.

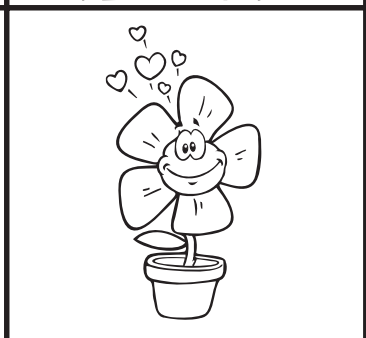
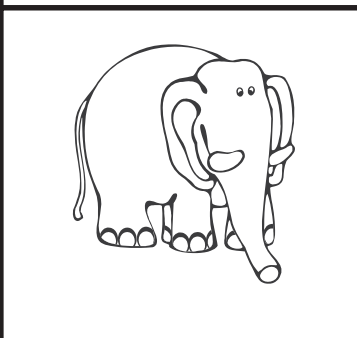
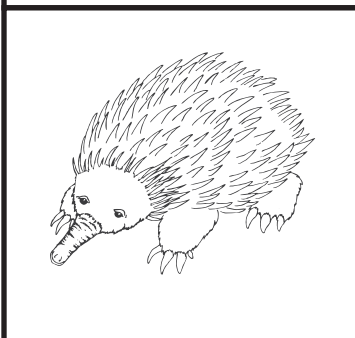
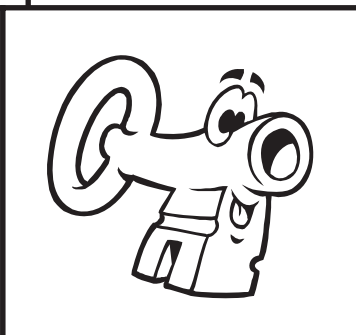
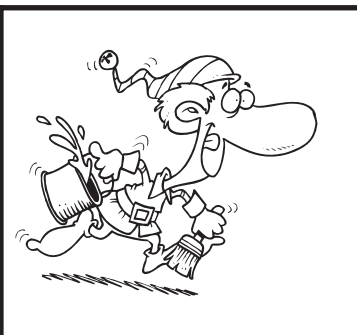
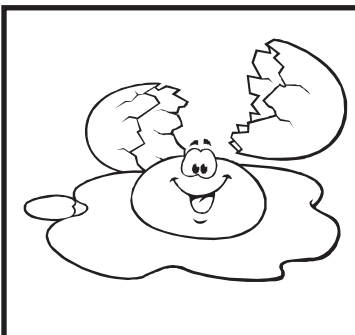

Trace the Easter eggs and draw some patterns on them.  
Read the sentence and trace the @ sounds.

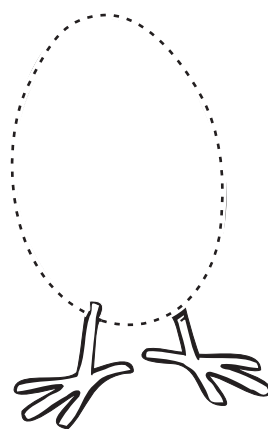
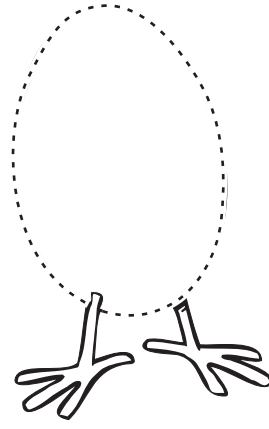
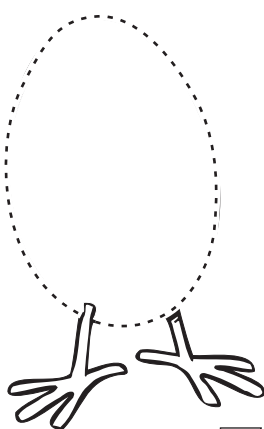
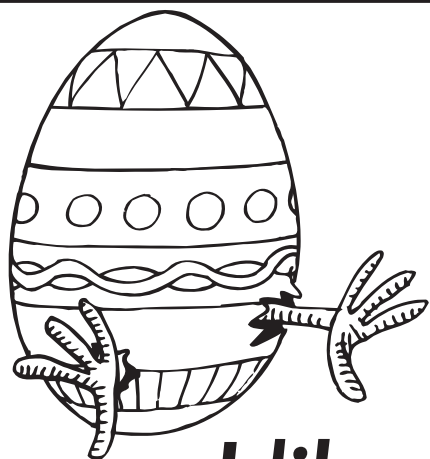

I like to @eat Easter @eggs.

e E

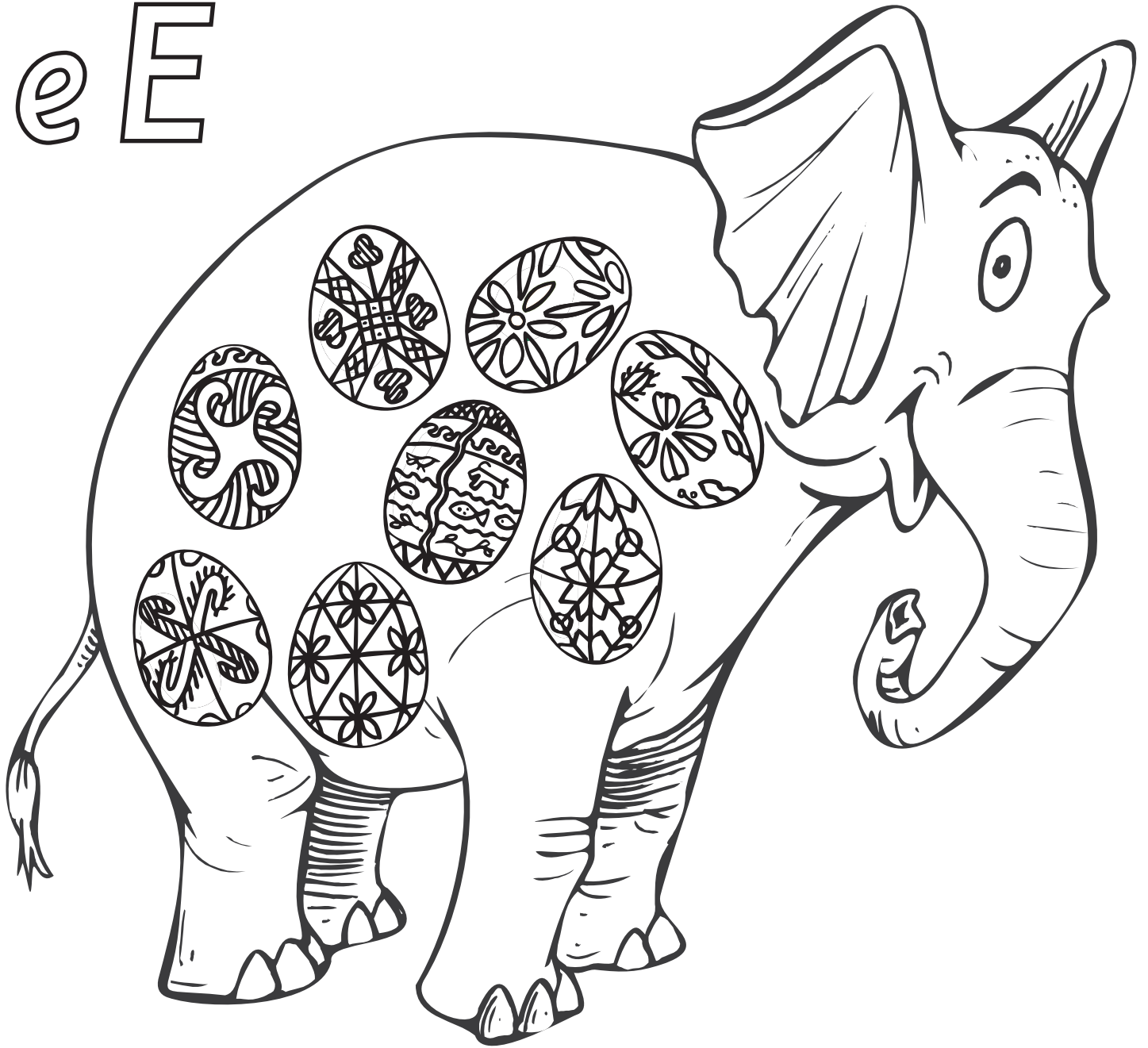

My *e*lephant ..... *e*ats lots  
of *E*aster *e*ggs.

- ☺ Colour in the Easter eggs inside the elephant in bright colours.
- ☺ Colour the rest of the elephant grey.
- ☺ Trace the *e* sounds and give the elephant a name starting with *E*.



e E

1. Colour the pictures that start with e.
2. Trace the e words.

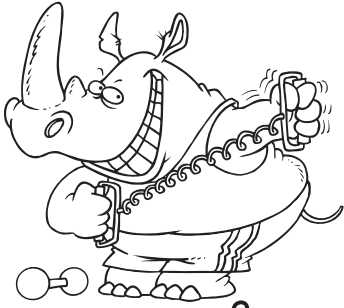

exercise



eggplant

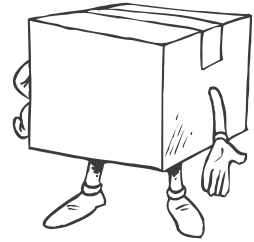

box



grapes



Eskimo



empty



face

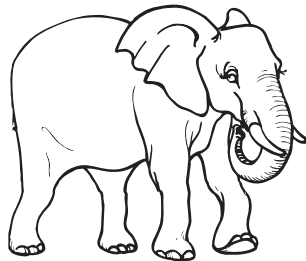

elephant



exit



enter

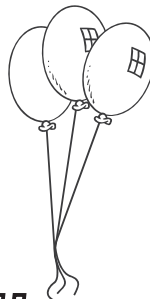

balloons

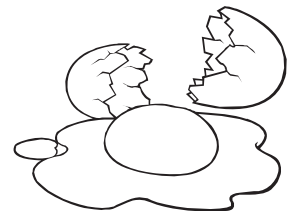

egg

Write some e words on another sheet  
or find some e pictures in magazines or newspapers.





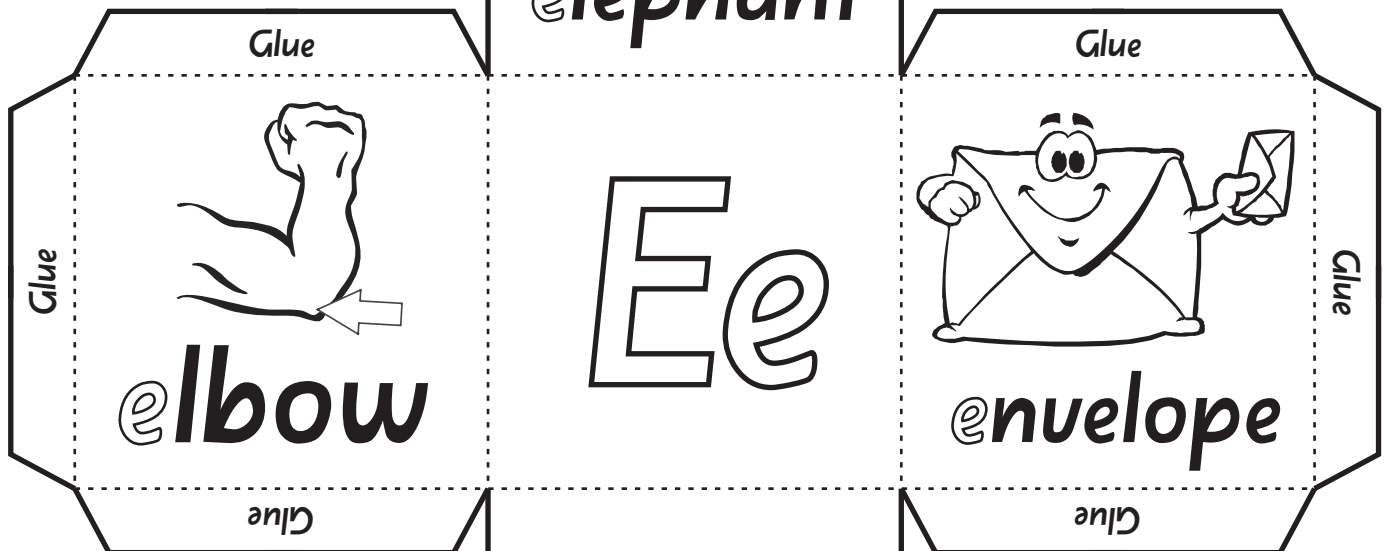
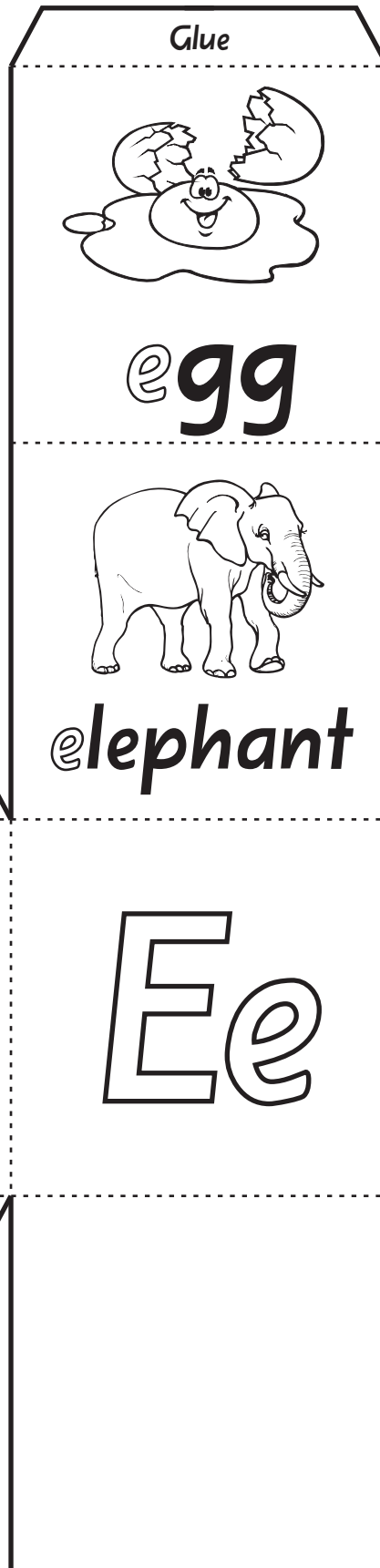
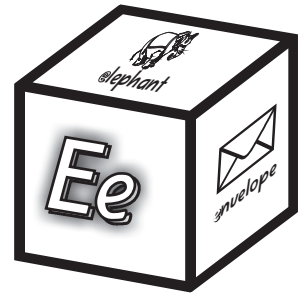

- ☺ Colour in the big Ee sounds.
- ☺ Colour the @ pictures.
- ☺ Trace over the @ sounds in the words.
- ☺ Draw your own @ picture in the blank square.

Cut along the straight lines and fold along the dotted lines. Glue it together to make a cube.

Trace any e sounds. Colour any picture that starts with e.



e

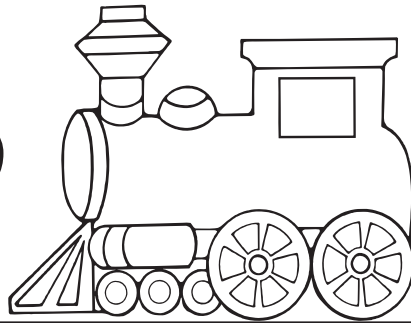

e



c

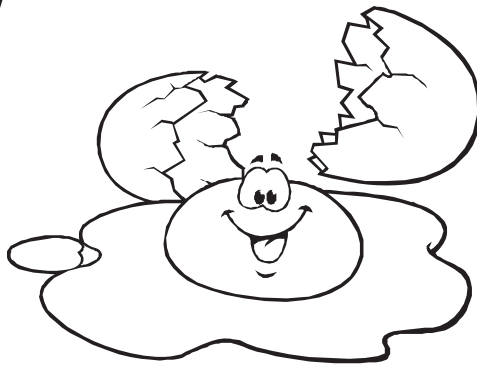

e

e



e

e gg

Draw your own e picture.

a

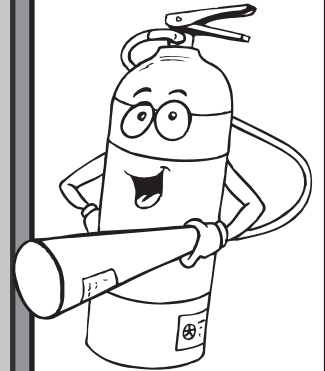

e

e

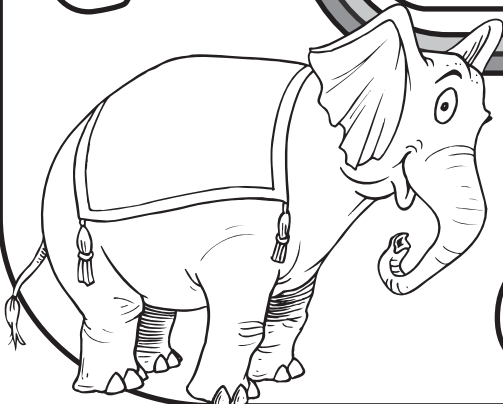

c



e

Draw a line to match the picture and word. Write the sound.

eE

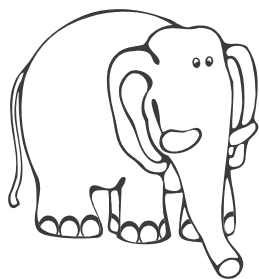

empty

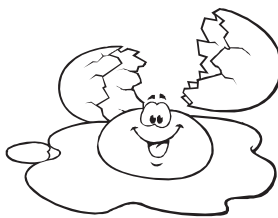

chicken

elbow

egg



elephant

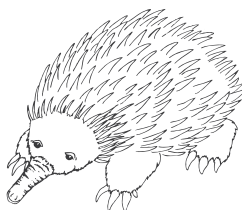

Circle the words that start with e.

enter      oval      eggs      elf      ate  
 elephant      empty      fairy  
 exercise      exit      car      explode

There are  e words.

Colour the pictures that start with e.

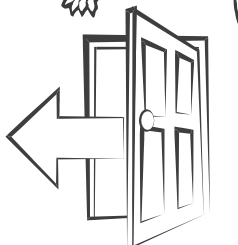
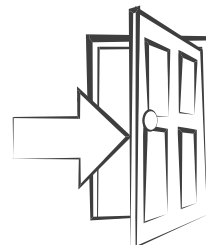
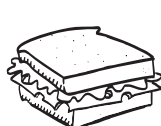
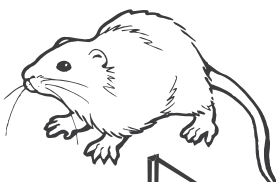

e E

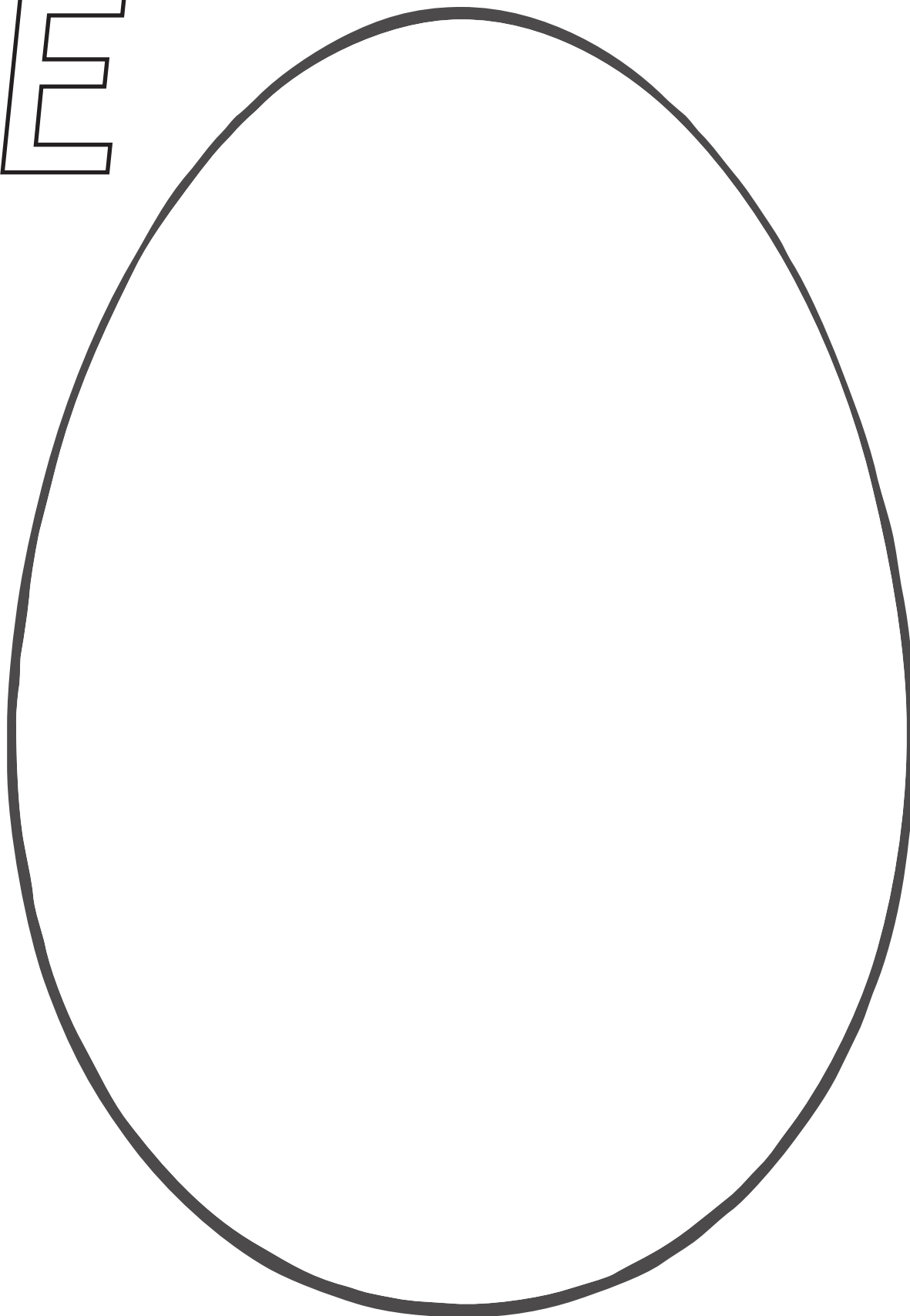

PICK A  
CRAFT  
IDEA



- 1** Decorate the egg with chipped paper.  
Paint a large rabbit and then paste these eggs around it.
- 2** Fill the egg with @ pictures or words.  
Paint a large basket. Paste the @ eggs in and around the basket.
- 3** Fold four eggs in half lengthwise and paste their backs together  
(each with an @ word written on it). Attach a string for a revolving @ mobile.

Trace the f sounds.

		<b>f</b>
		<b>fish</b>

Colour the pictures that start with f.

Trace the fish in the bowl and colour them.  
Read the sentence and trace the f sounds.

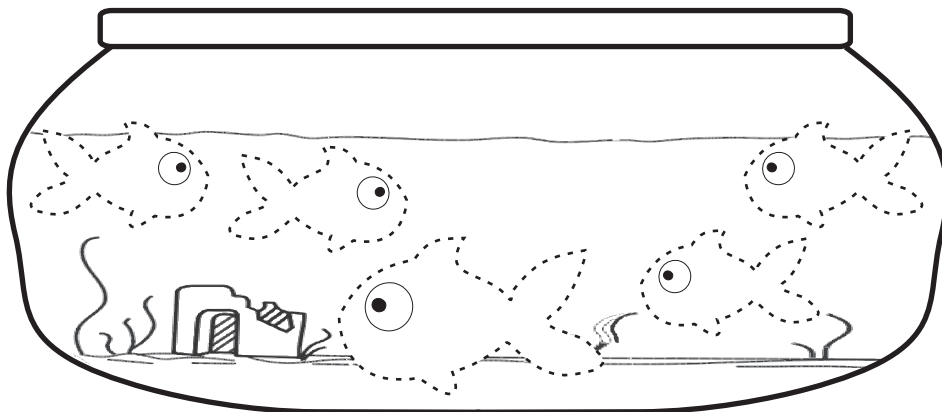

**Five fish in a fishbowl.**

f F

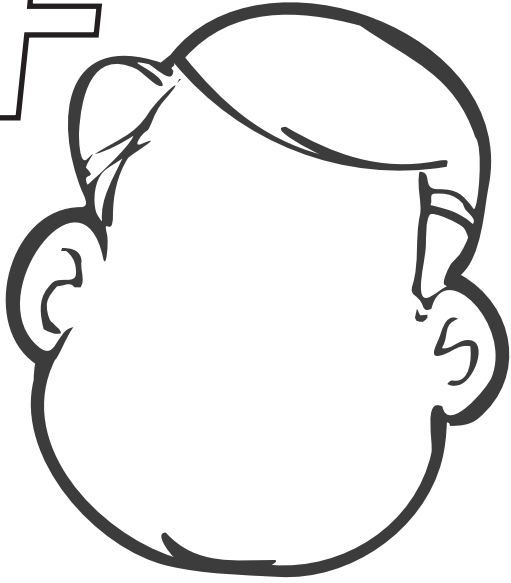

..... *face*



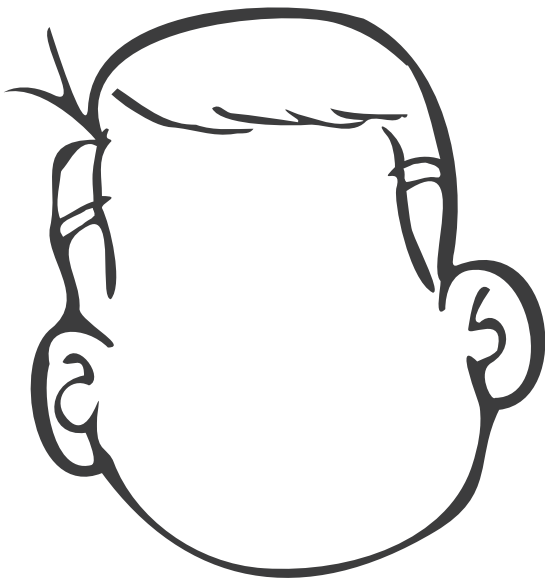

..... *face*

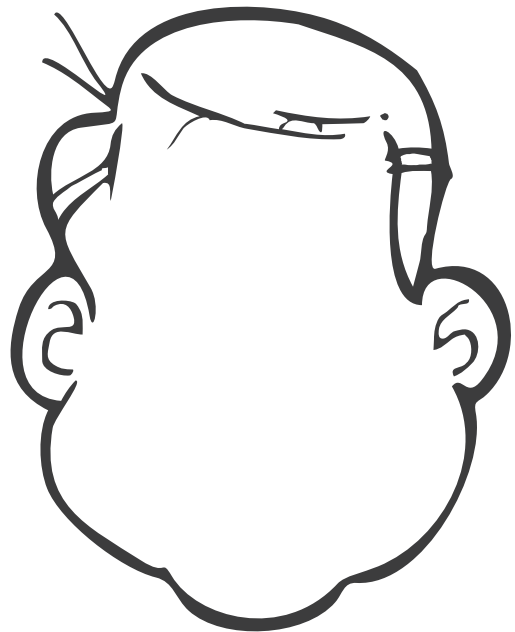

..... *face*



..... *face*

-  Draw a different facial expression on each face e.g. happy, sad, frightened, excited, angry etc.
-  Write in the type of face under each picture.
-  Trace over the *f* sound.

# fF

1. Colour the pictures that start with f.
2. Trace the f words.

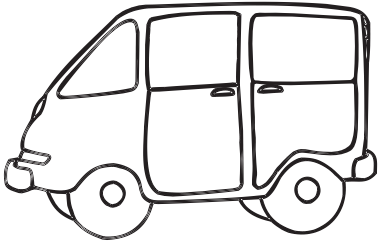

van



family

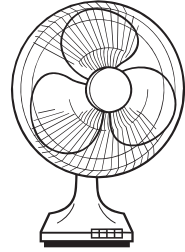

fan

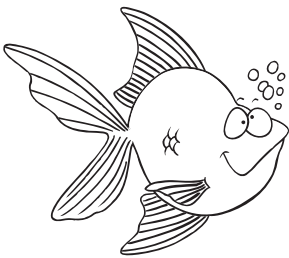

fish

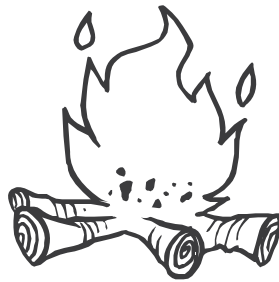

fire

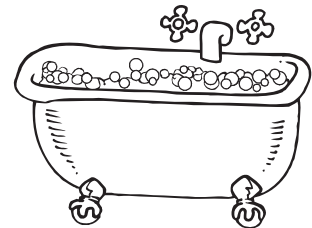

tub

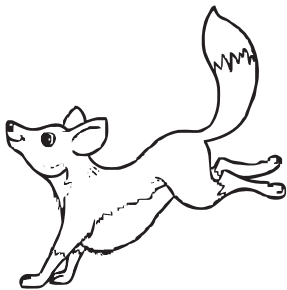

fox



fall



farmer



umbrella



feet



fax

Write some f words on another sheet  
or find some f pictures in magazines or newspapers.

EXTRA  
STUFF



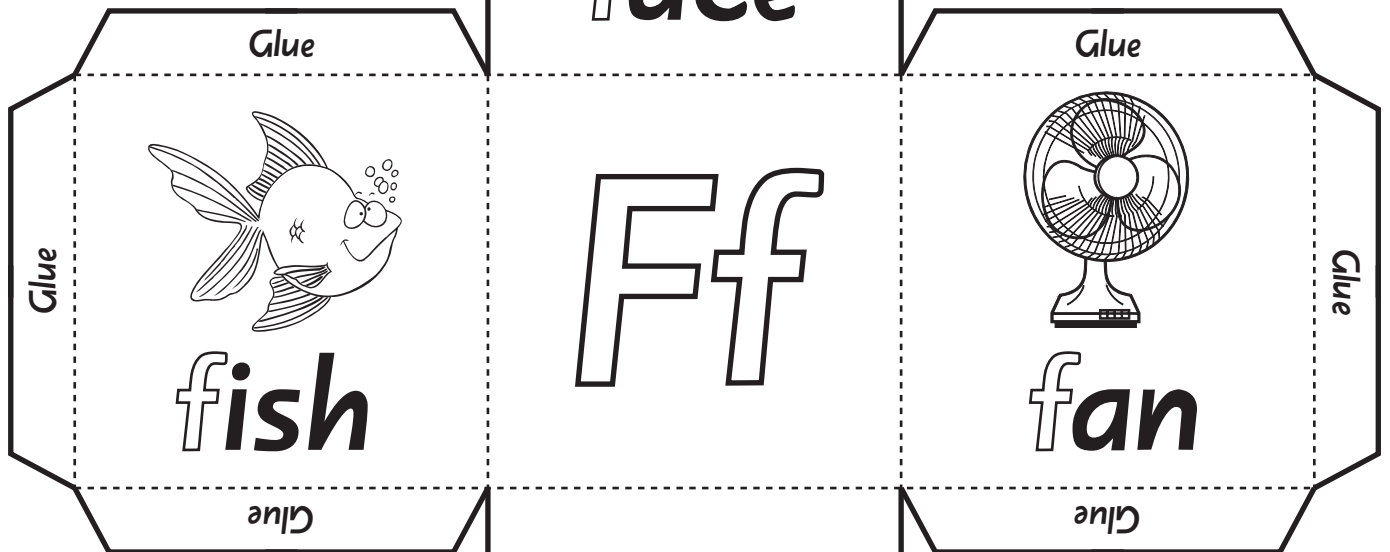
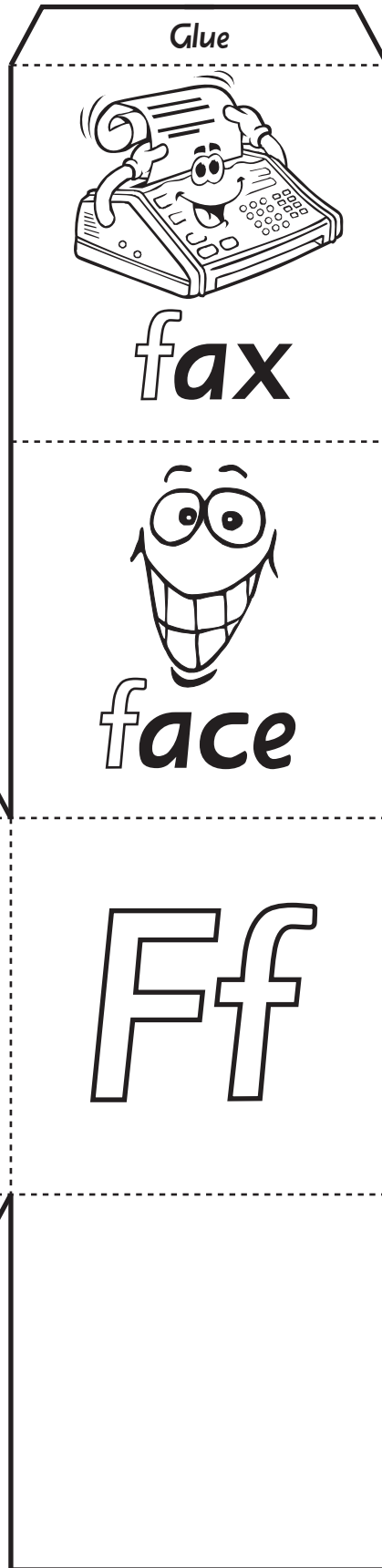
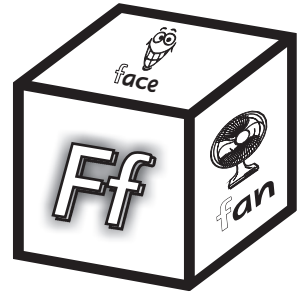

- ☺ Colour in the big **Ff** sounds.
- ☺ Colour the **f** pictures.
- ☺ Trace over the **f** sounds in the words.
- ☺ Draw your own **f** picture in the blank square.

Cut along the straight lines and fold along the dotted lines. Glue it together to make a cube.



Trace any f sounds. Colour any picture that starts with f.



f

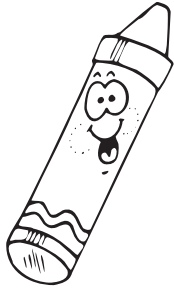

f

f

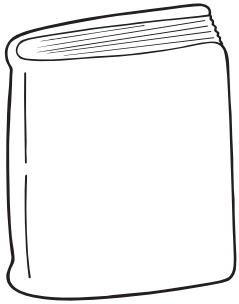
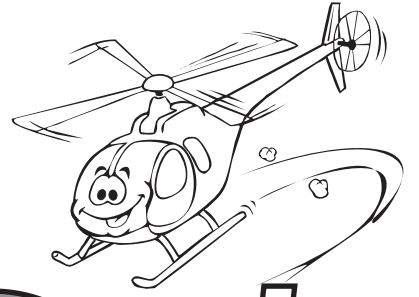

f

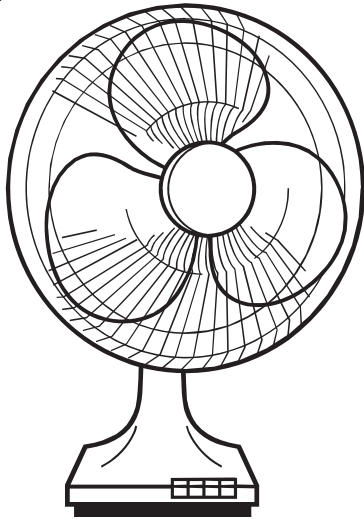

f

fan

k

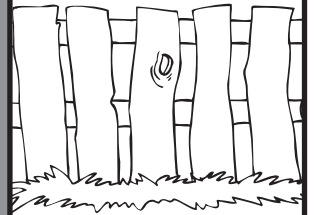

f

Draw your own f picture.

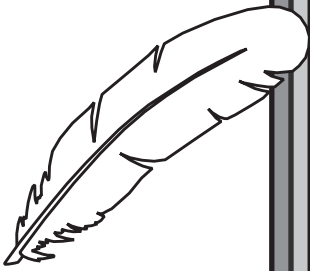
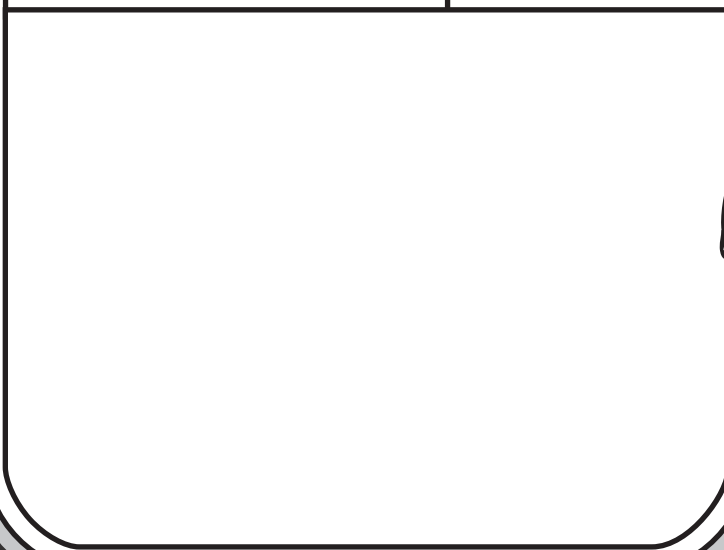

f

f

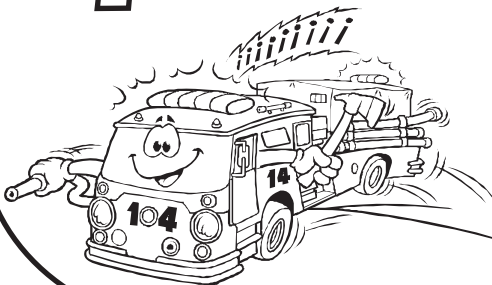

f



h



fF

Draw a line to match the picture and word. Write the sound.



ang



all

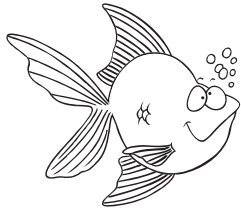

in



ire

ish

Circle the words that start with f.

food    fork    tall    fold    fly  
kite    foot    home    fake  
open    fit    find    feet    fill

There are  f words.

Colour the pictures that start with f.

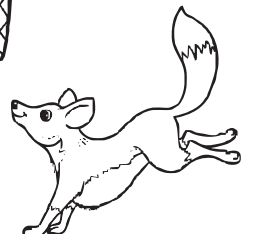
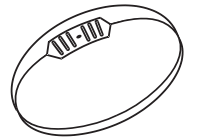
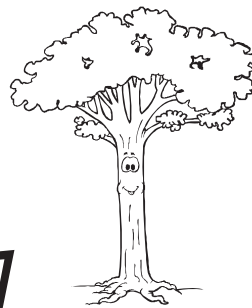
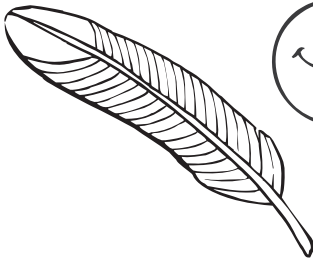
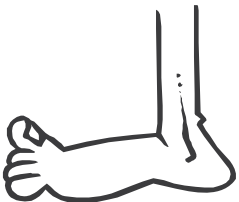

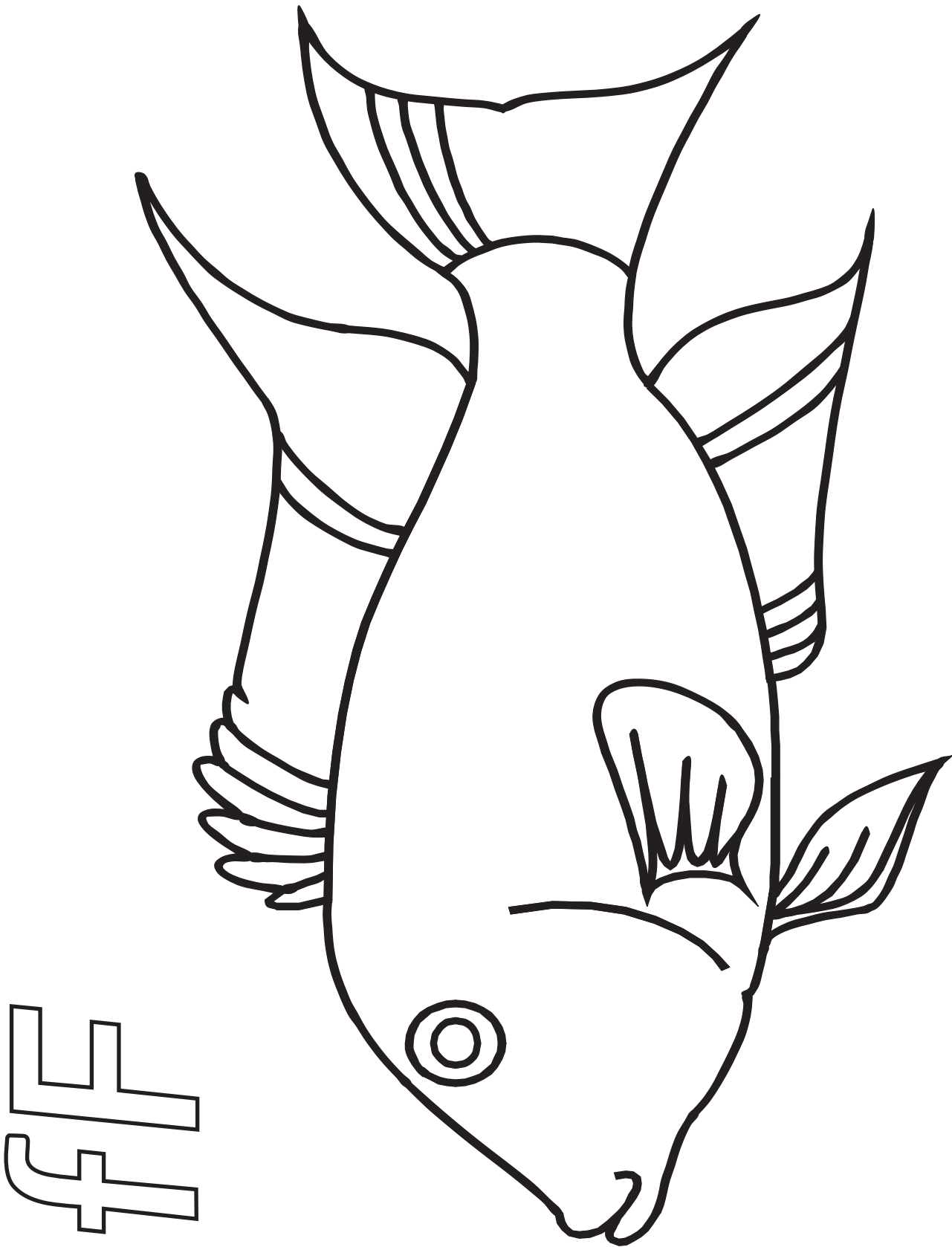

- 1** Paint the fish in any colours. When dry add patterns or scales using crayons. Paint a watery background using crumpled newspaper as a brush.
- 2** Use fingerprinting to print scales of different colours on the fish. Paint the background blue. Add shells, seaweed, other fish etc.
- 3** Paint the background blue and cover the fish with *f* words or pictures. Colour in the spaces with coloured chalk.

Trace the *g* sounds.

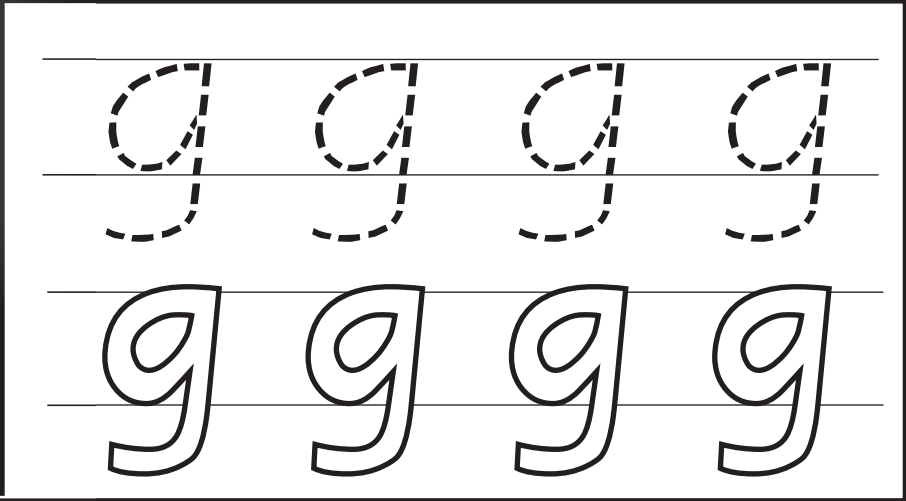

Colour the pictures that start with *g*.

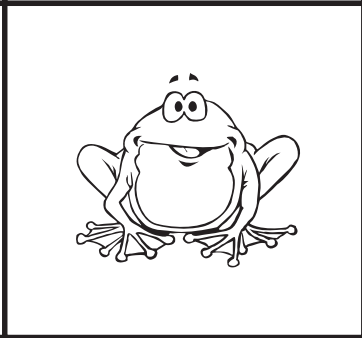
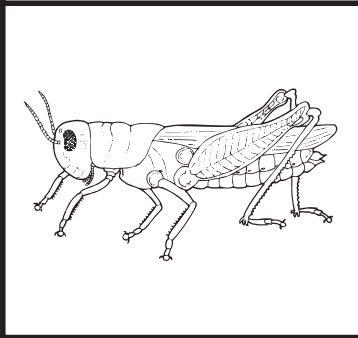
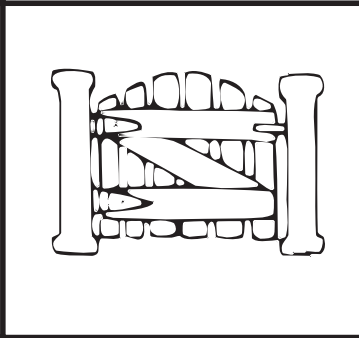
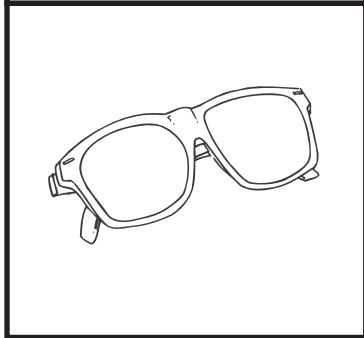
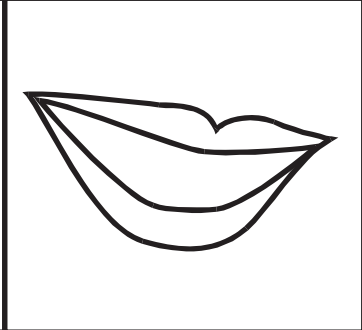
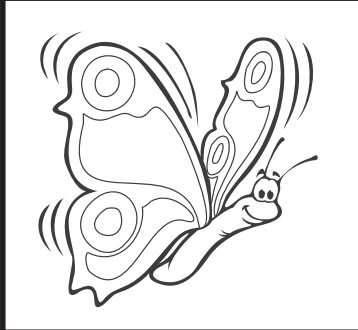
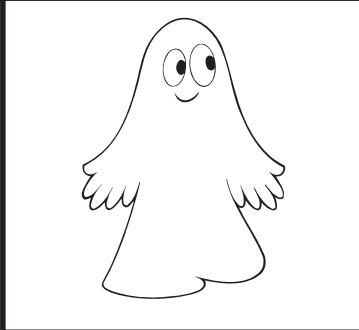

Trace the goats and draw some green grass.  
Read the sentence and trace the *g* sounds.

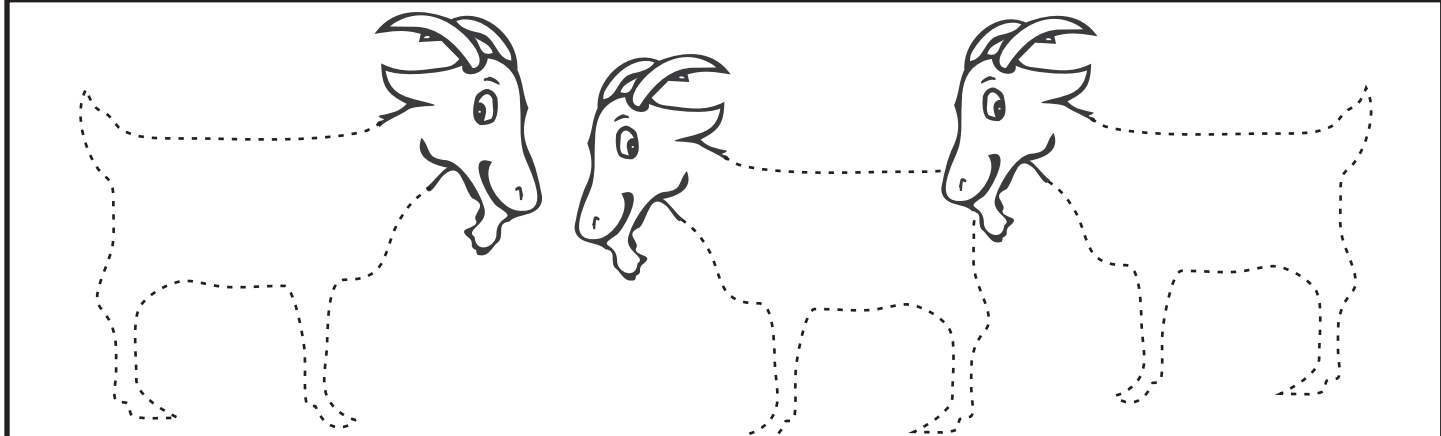

Goats in the *g*reen *g*rass.

g G



**The *g*irl has her own *g*arden.**

-  Draw the girl's garden and colour the picture.
-  Trace over the *g* sounds in the sentence.

# g G

1. Colour the pictures that start with *g*.
2. Trace the *g* words.



kangaroo



mower

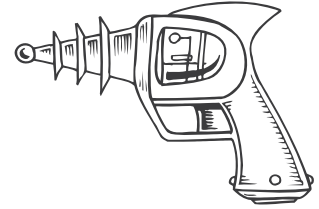

gun



girl

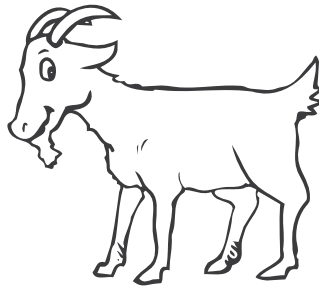

goat

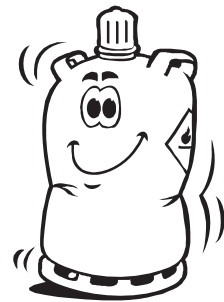

gas

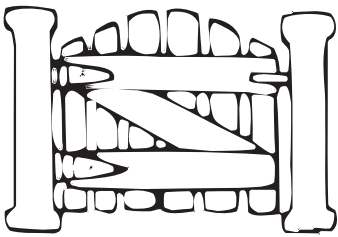

gate

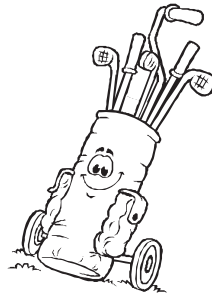

golf bag



pig

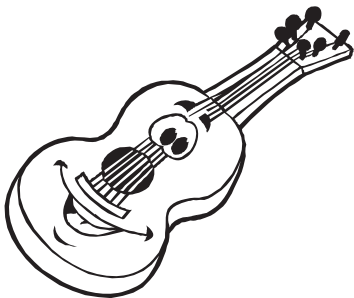

guitar



bow

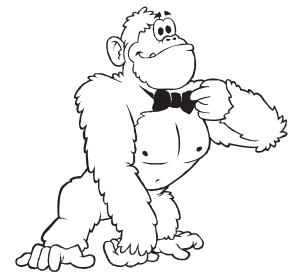

gorilla

Write some *g* words on another sheet  
or find some *g* pictures in magazines or newspapers.



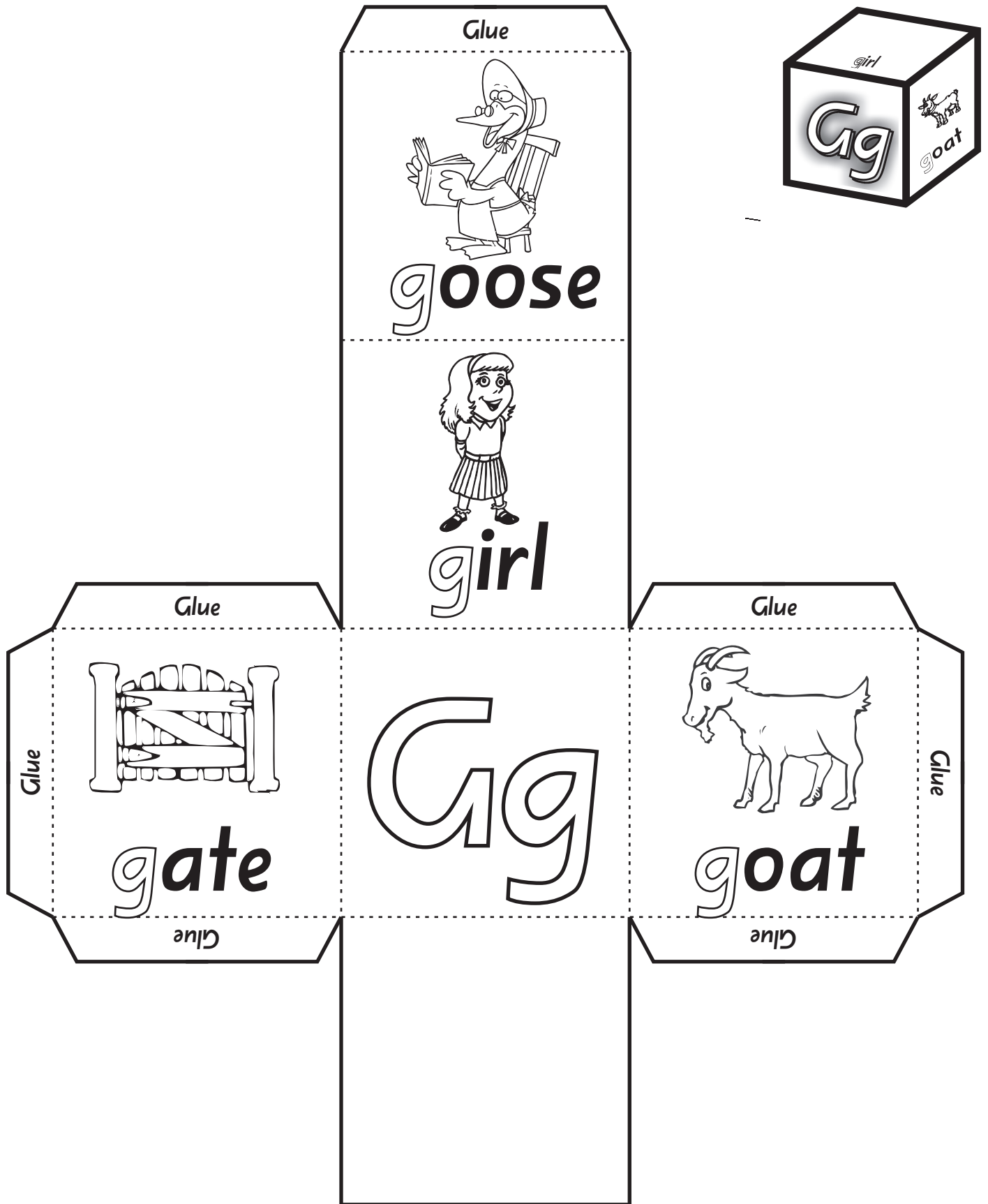

Colour in the big Gg sounds.



Colour the g pictures.



Trace over the g sounds in the words.



Draw your own g picture in the blank square.

Cut along the straight lines and fold along the dotted lines. Glue it together to make a cube.



Trace any *g* sounds. Colour any picture that starts with *g*.

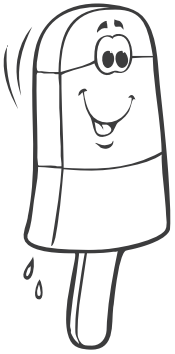

*P*

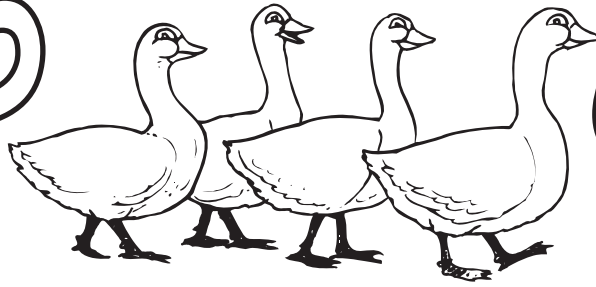

*g*



*g*



*g*

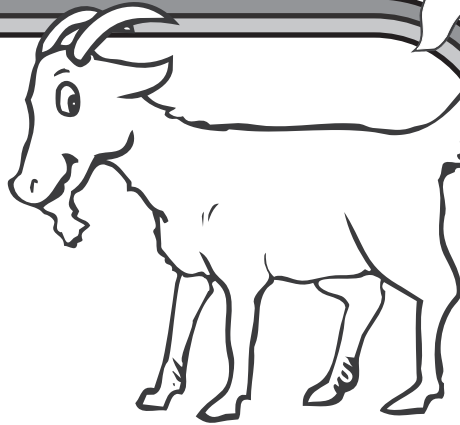

**goat**

*g*

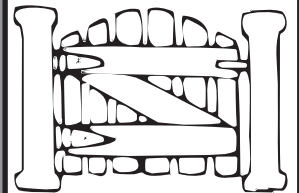

*g*

Draw your own *g* picture.

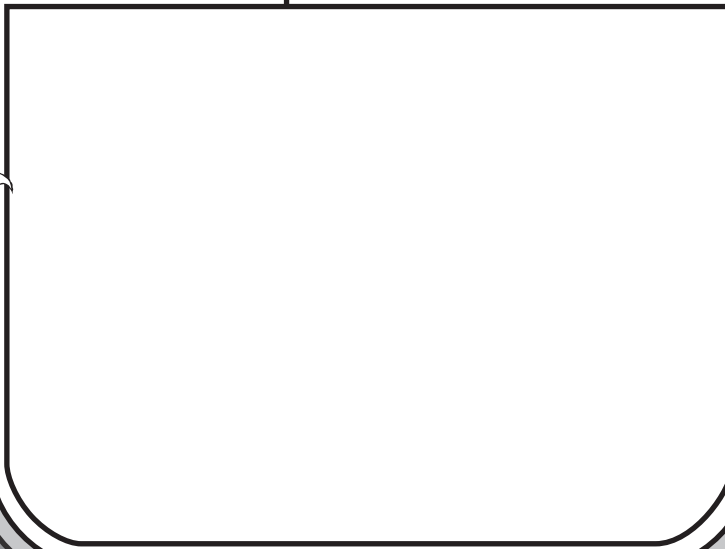

*y*

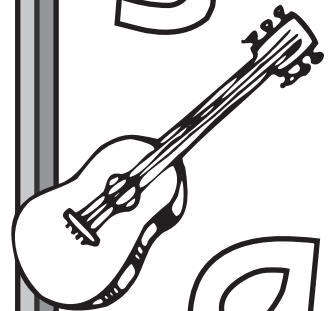
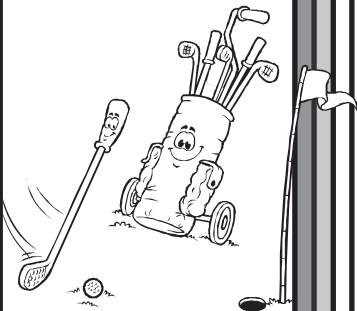

*g*

*g*

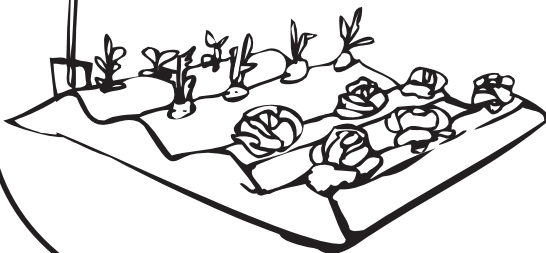

*g*



Draw a line to match the picture and word. Write the sound.

g G



irl

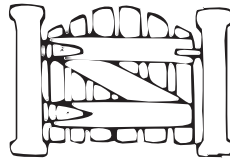

ears

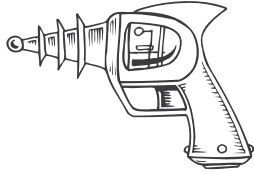

ift



ate

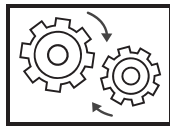

un

Circle the words that start with g.

gone yap gun goat go  
 joy gong got game  
 home gate gale gas

There are  g words.

Colour the pictures that start with g.

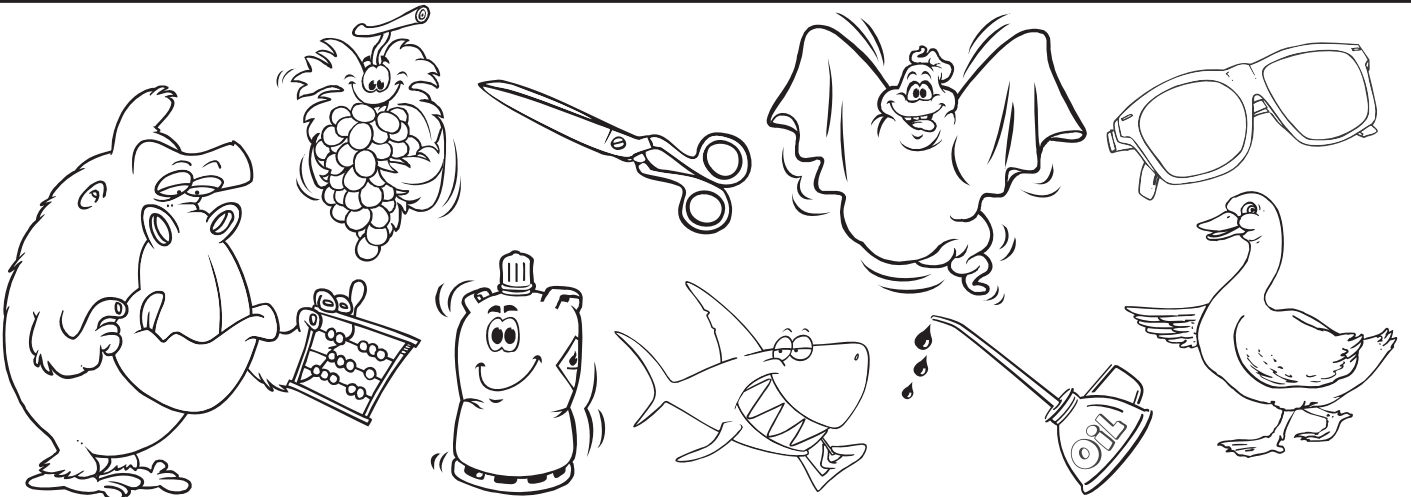

gG



- 1** Colour the ghost with thick white crayon and then paint over the sheet with a wash of dark blue or black paint.
- 2** Draw a background of buildings using black crayon. Apply a thin black wash. Paint ghosts yellow, cut out and paste on background.
- 3** Each student receives two ghosts and writes a *g* word on each. Paste them back to back with string in the middle. Hang around the room.

Trace the *h* sounds.

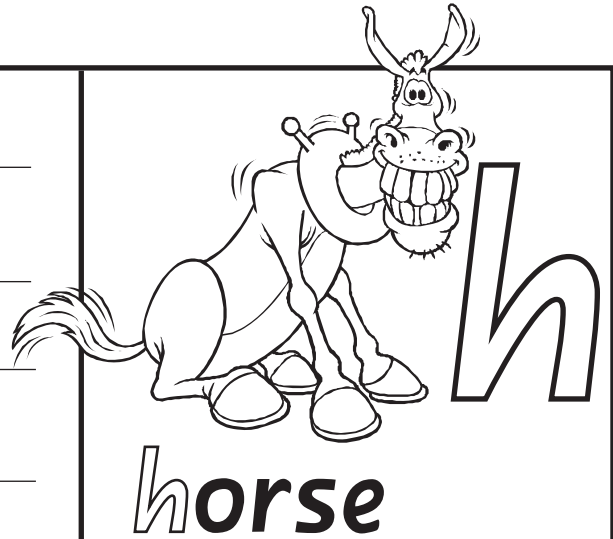
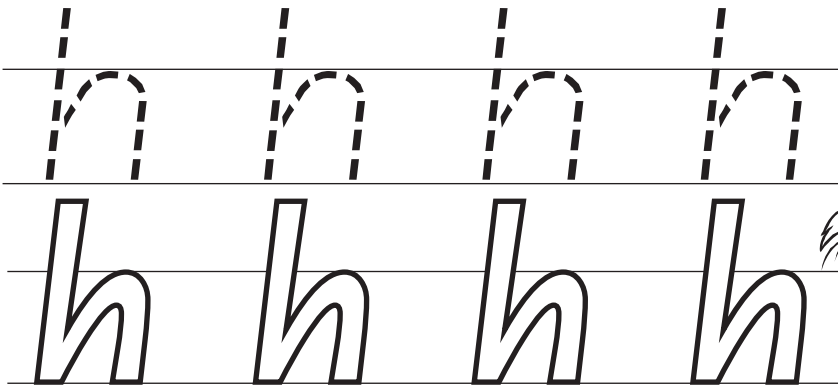

Colour the pictures that start with *h*.

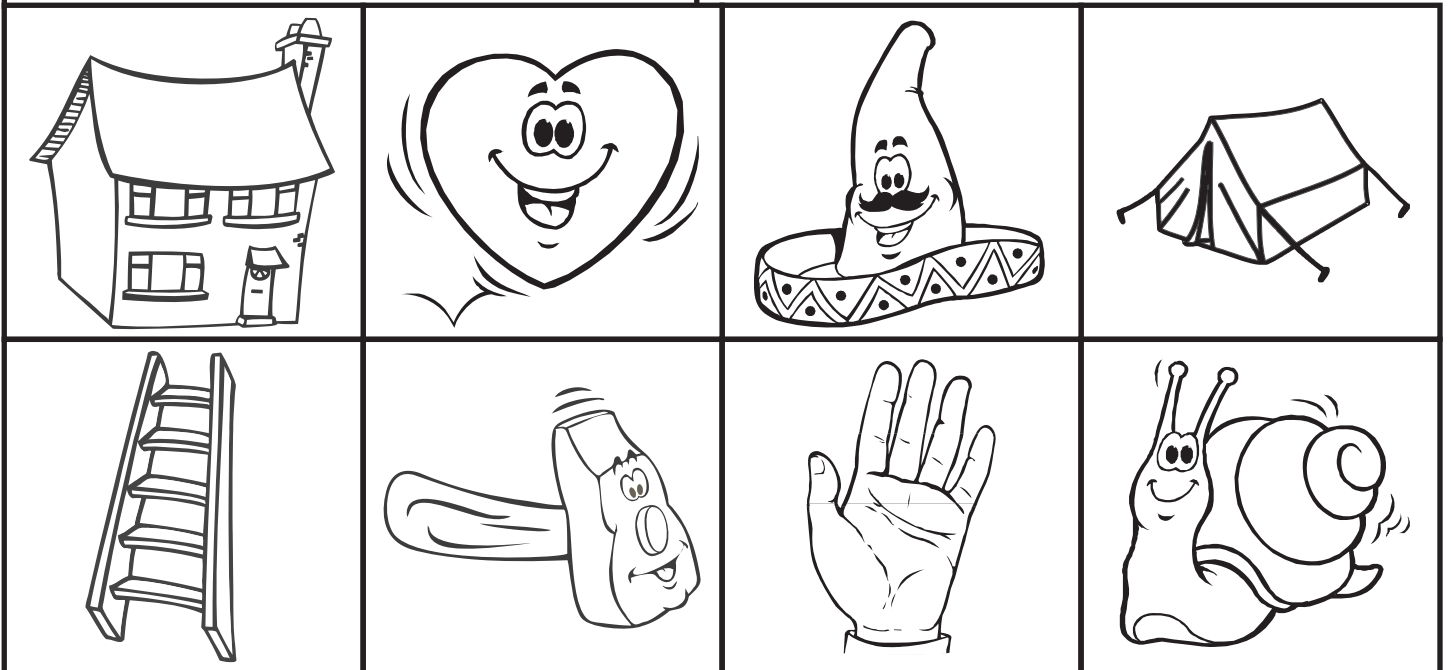

Trace the hearts and colour in the hats.  
Read the sentence and trace the *h* sounds.

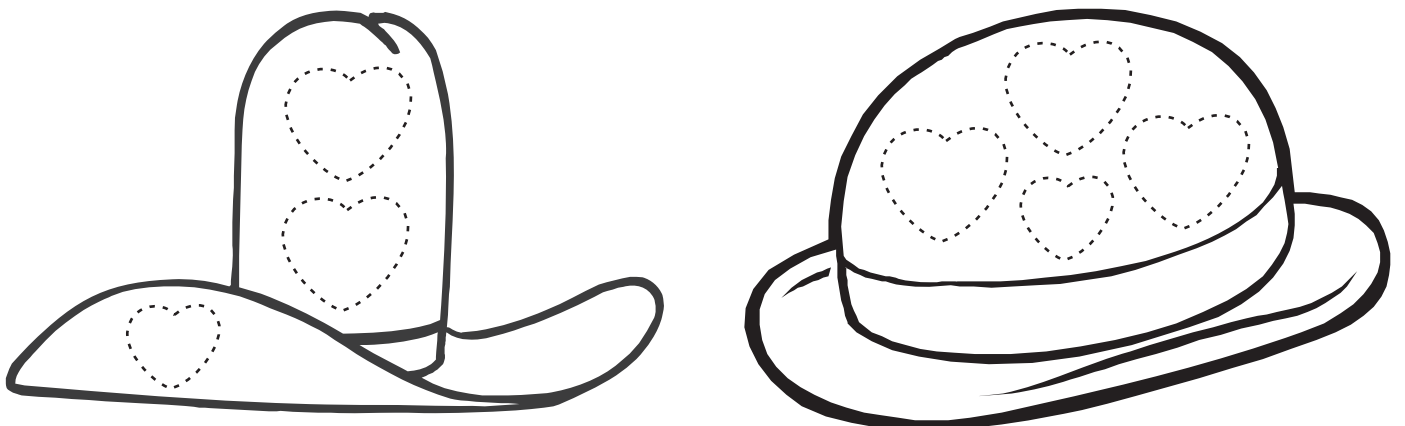



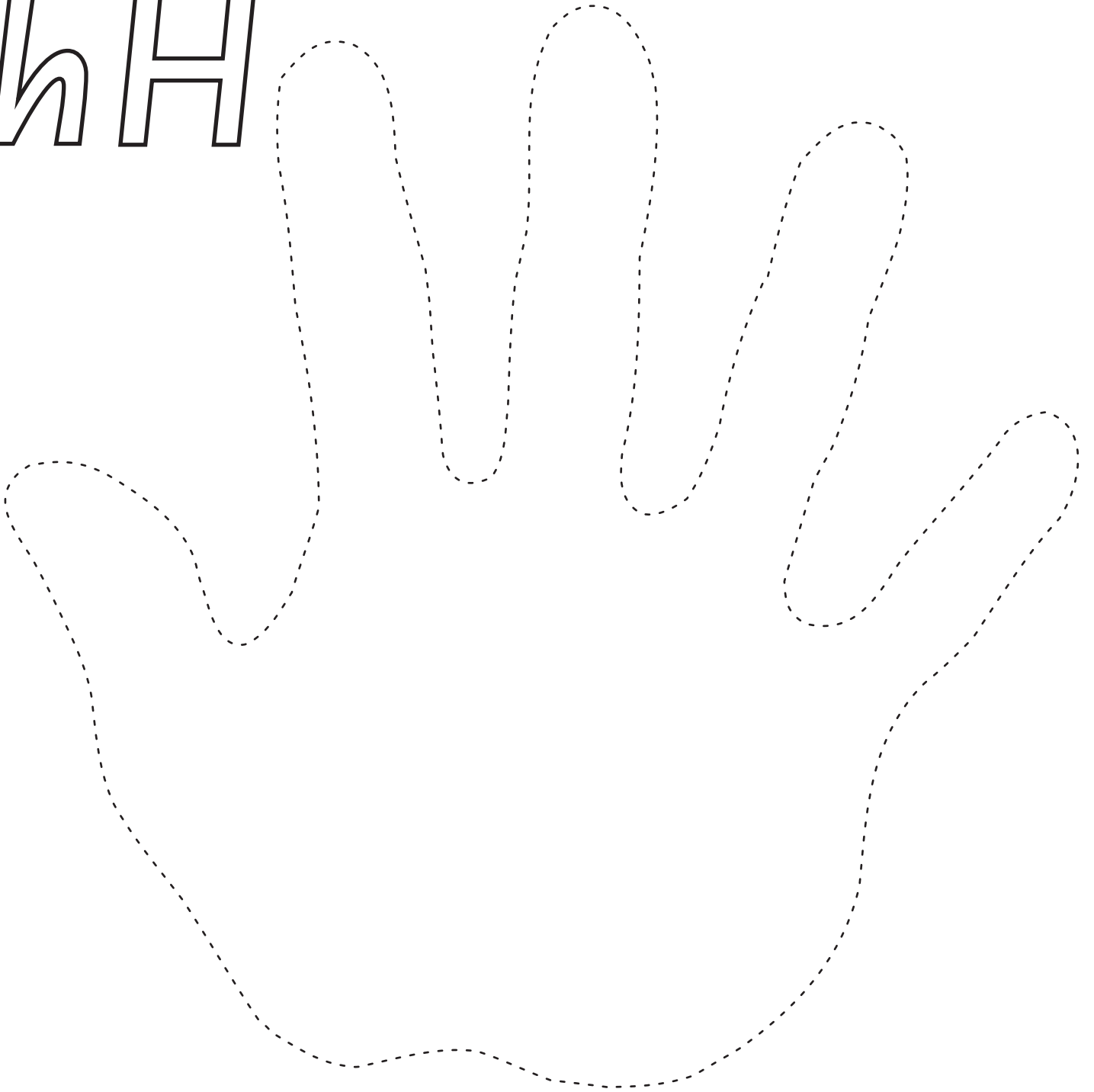

How many *h*earts are on the *h*ats?

h H



There are  hearts on the *h* hand.

-  Trace over the hand.
-  Draw heart shapes on the hand.
-  Write the number of hearts in the sentence.
-  Trace over the *h* sounds in the sentence.

# hH

1. Colour the pictures that start with h.
2. Trace the h words.

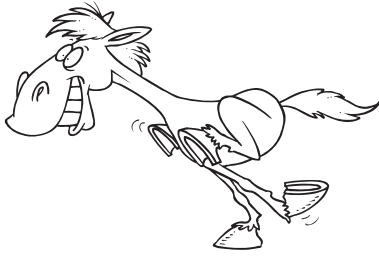

horse



hot dog

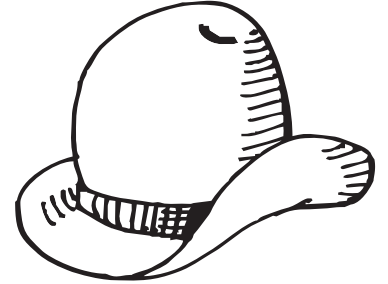

hat

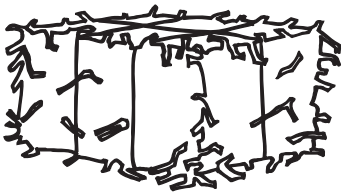

hay



frog

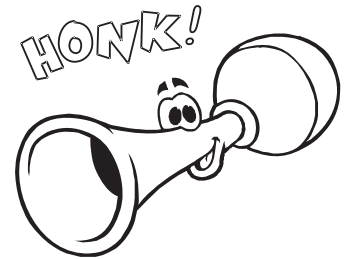

horn



hen

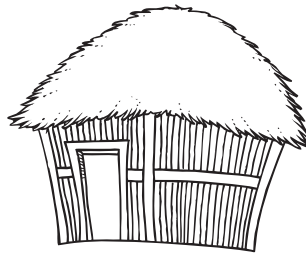

hut

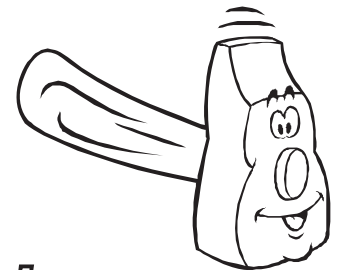

hammer

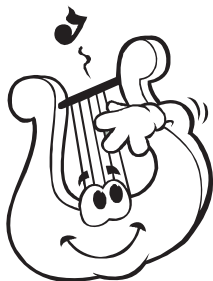

harp



hand



tap

Write some h words on another sheet  
or find some h pictures in magazines or newspapers.



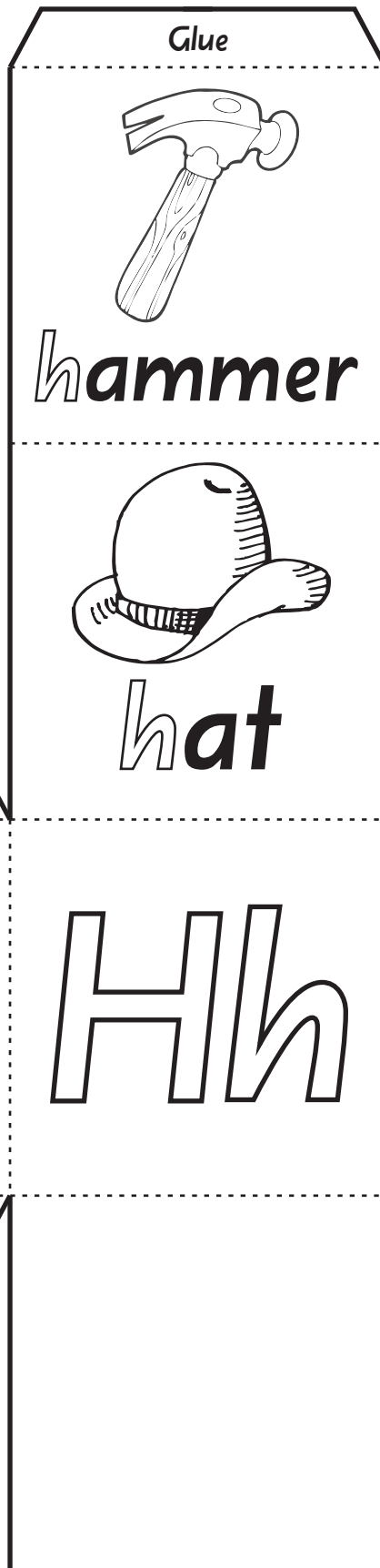
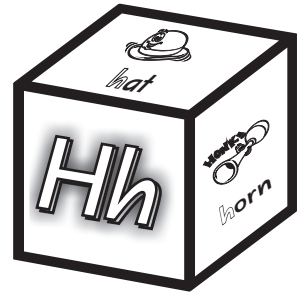

Colour in the big **Hh** sounds.



Colour the **h** pictures.



Trace over the **h** sounds in the words.



Draw your own **h** picture in the blank square.

Cut along the straight lines and fold along the dotted lines. Glue it together to make a cube.



Trace any h sounds. Colour any picture that starts with h.

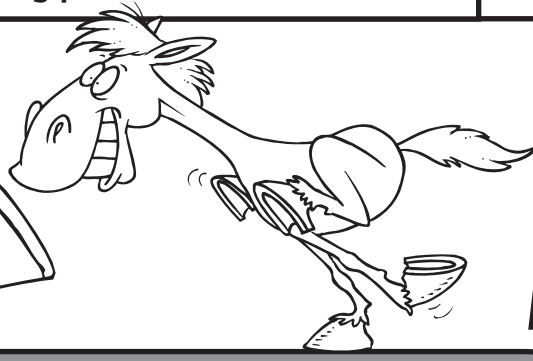
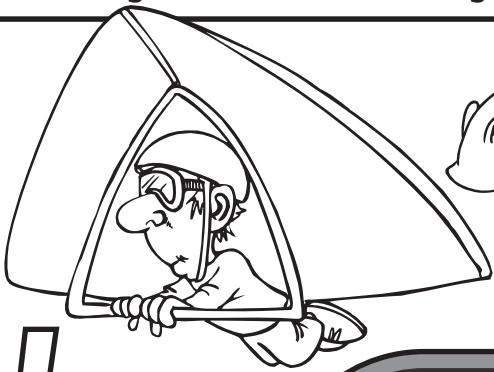

h

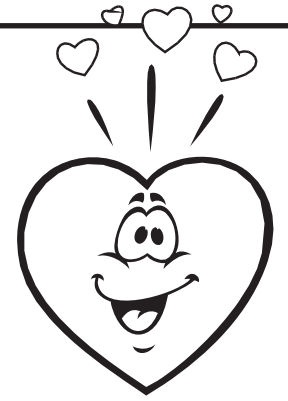

h

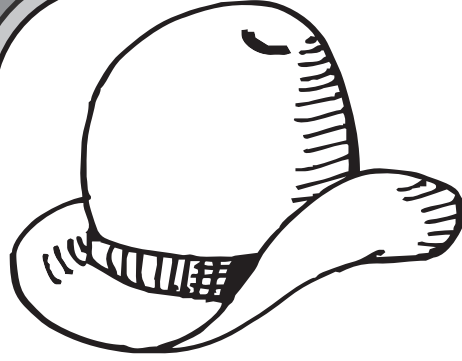

hat

h

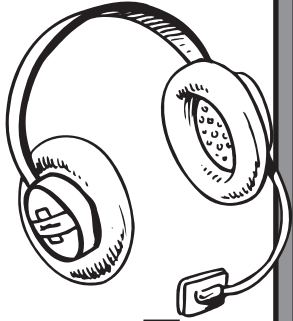

h

Draw your own h picture.

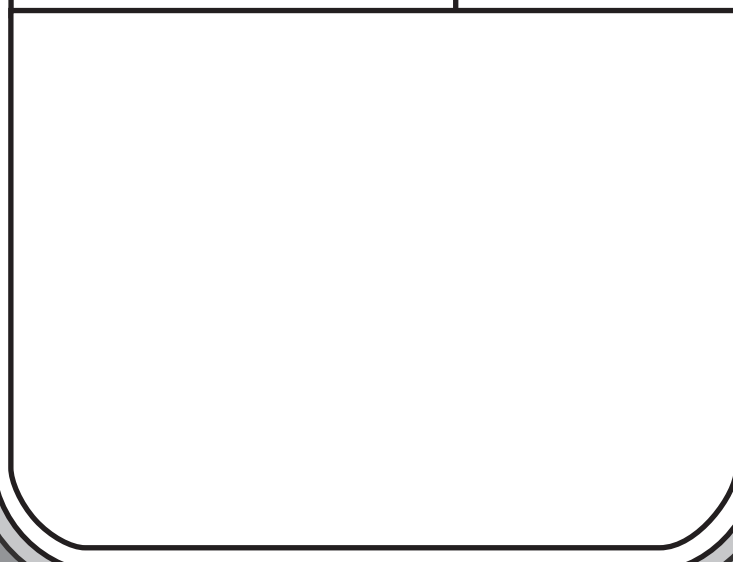

h

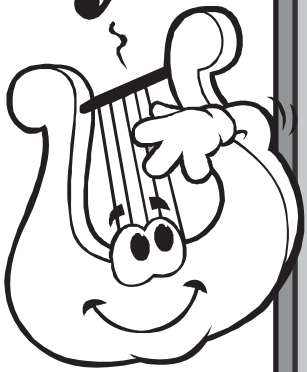

h

h



h



h



h H

Draw a line to match the picture and word. Write the sound.

atch

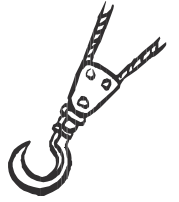
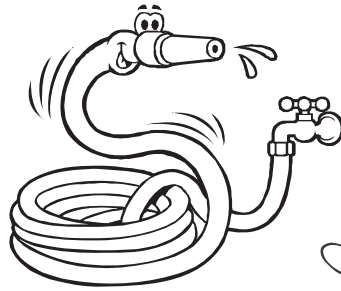

oney

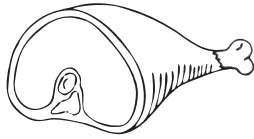

ook

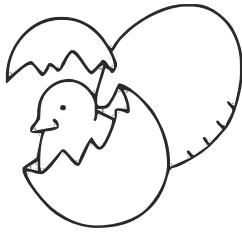

am

ose

Circle the words that start with h.

hide hare nut heart

him hat her he his

but hive how bus hoop

There are  h words.

Colour the pictures that start with h.

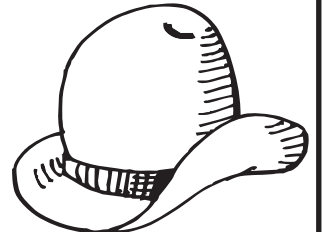
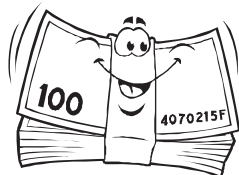
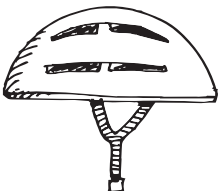

# h

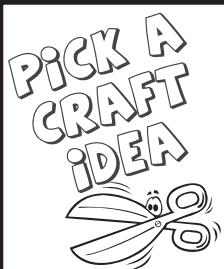
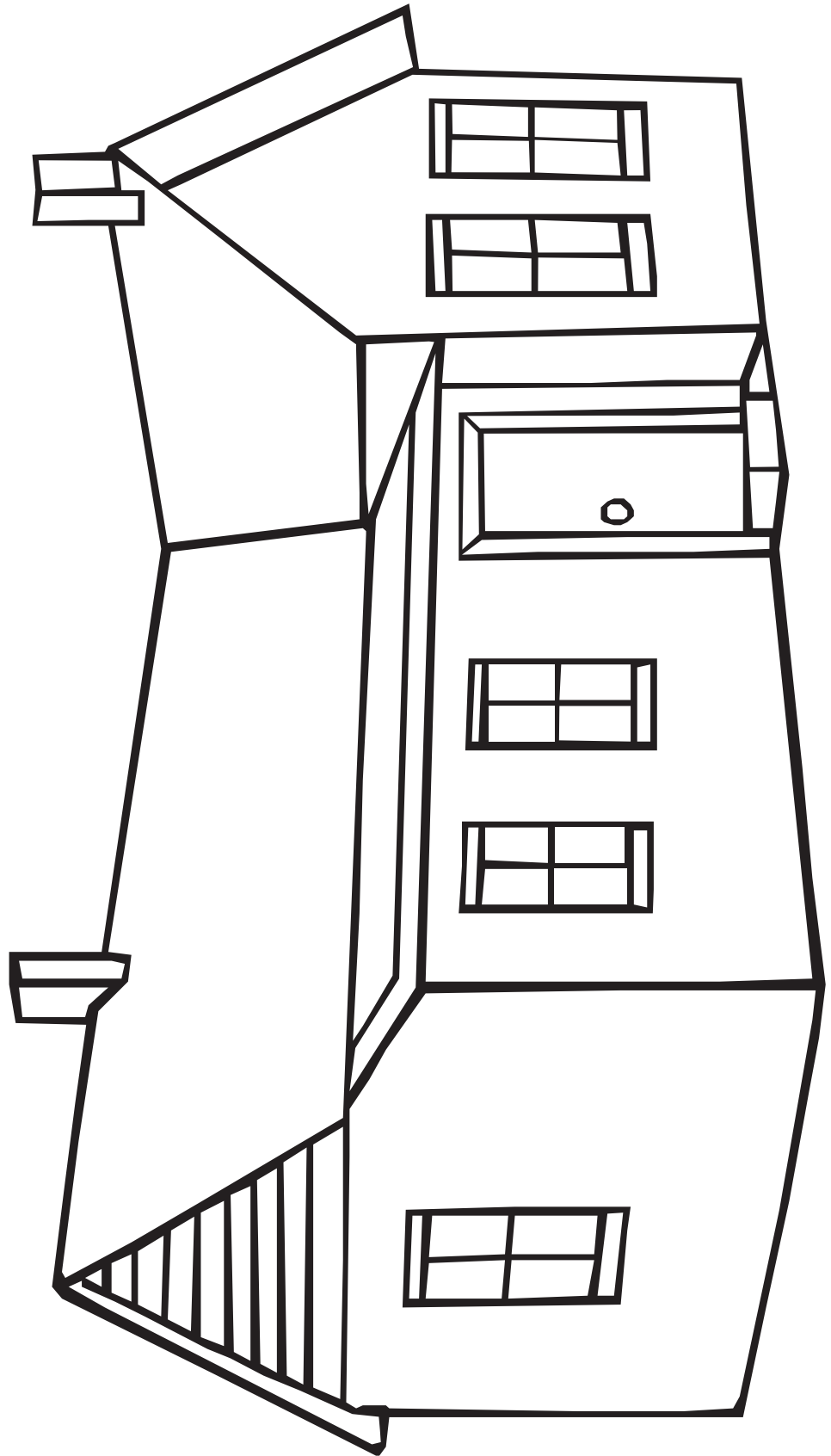

- 1** Write *h* words on the walls and roof of the house.  
Colour the house with pencils, felt pens etc. Colour the background with chalk.
- 2** Colour the house without enlarging it and paste it onto a large piece of paper.  
Draw a long winding path leading to the door filled with *h* words.
- 3** Paint a large background with streets, parks etc.  
Colour the houses and cut them out and paste onto the background.

Trace the i sounds.

i

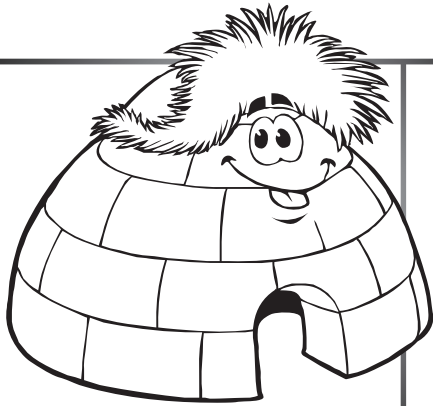

igloo

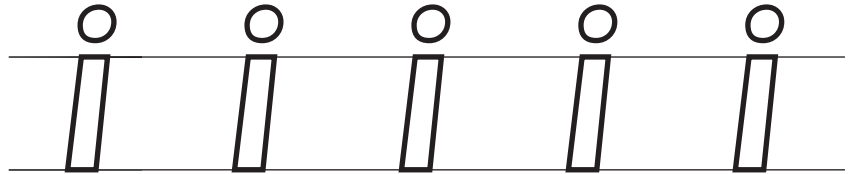
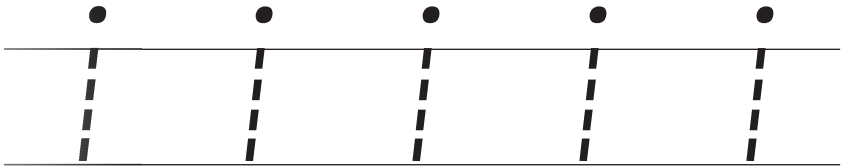

Colour the pictures that start with i.

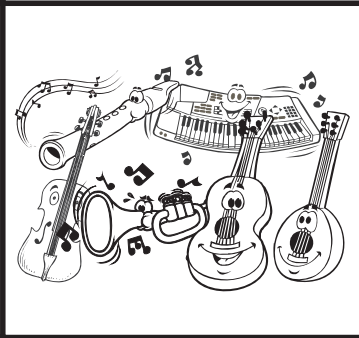
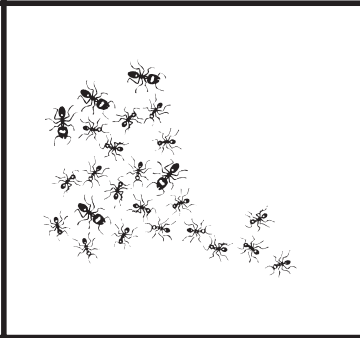
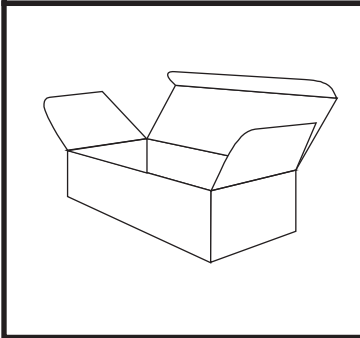
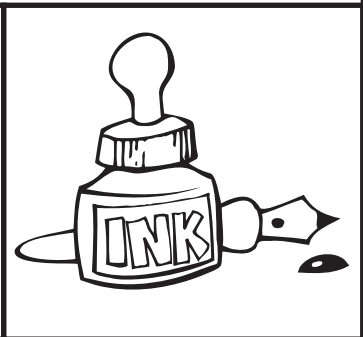
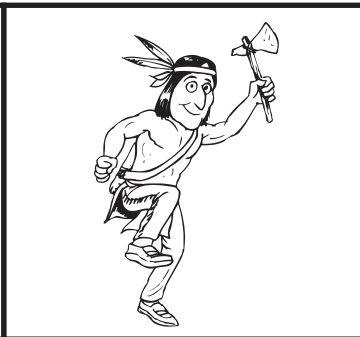
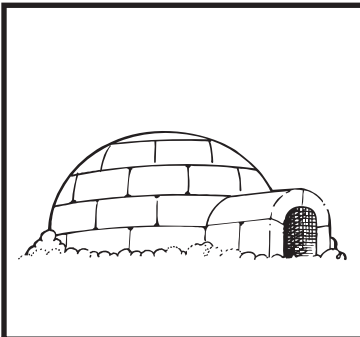

Colour and count the insects.  
Read the sentence and trace the i sounds.

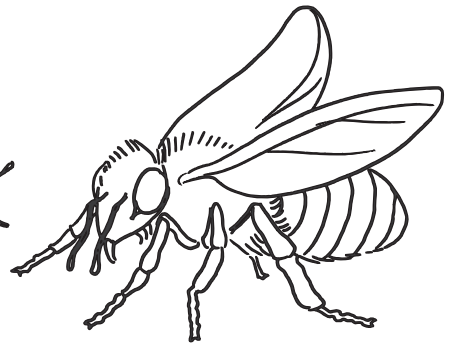
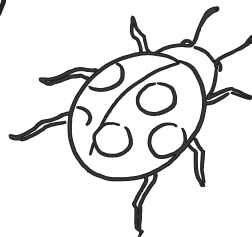
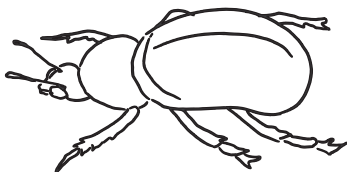
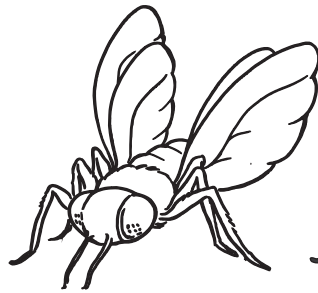
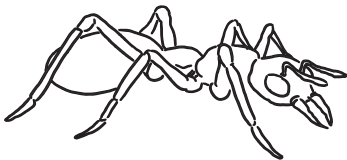

There are ..... i insects.

i |

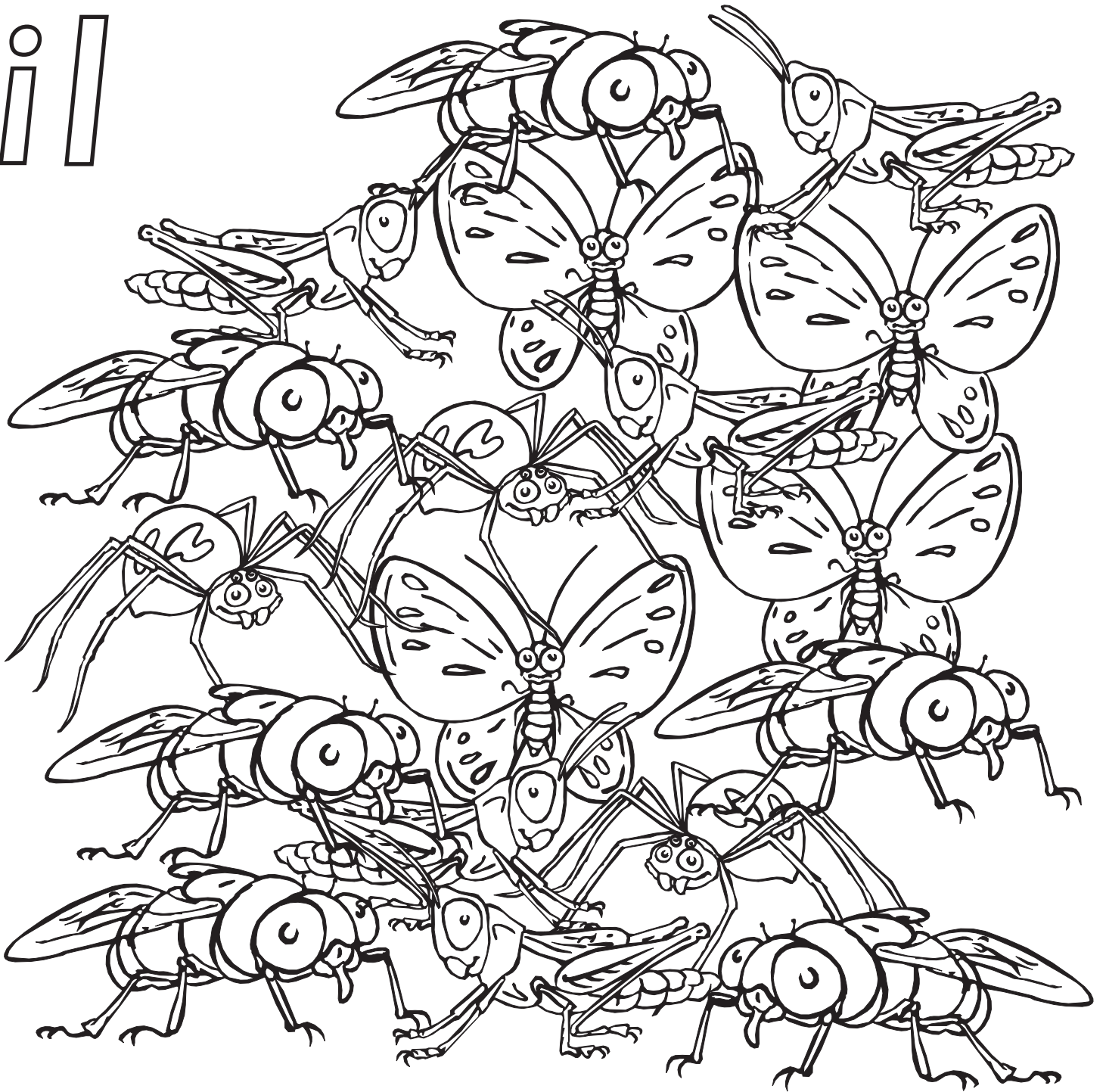



There are ..... 

There are ..... 

There are ..... 

There are ..... 

-  Colour each group of insects a different colour.
-  Count the number of each type of insect and write it in the correct space.



i l

1. Colour the pictures that start with i.
2. Trace the i words.



wave

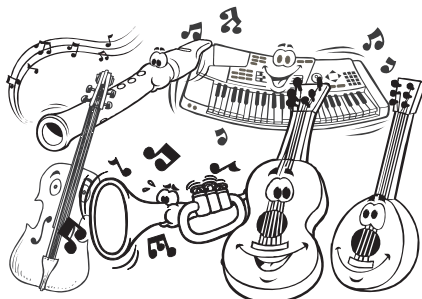

instruments

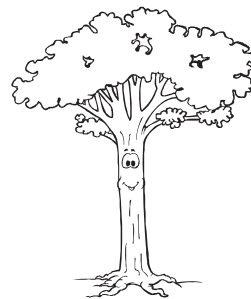

tree

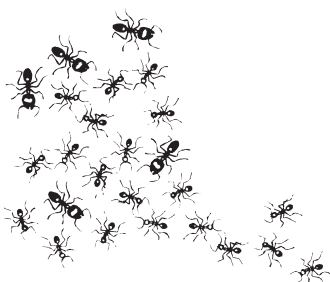

insects



igloo

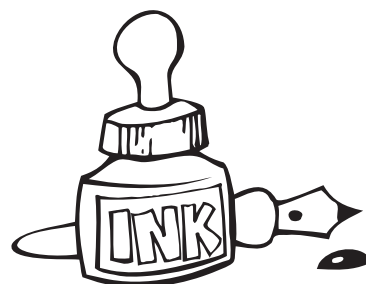

ink



injection



invitation



house

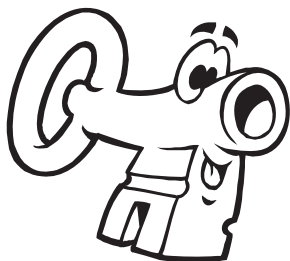

key



chicken



Indian

Write some i words on another sheet  
or find some i pictures in magazines or newspapers.

EXTRA  
STUFF



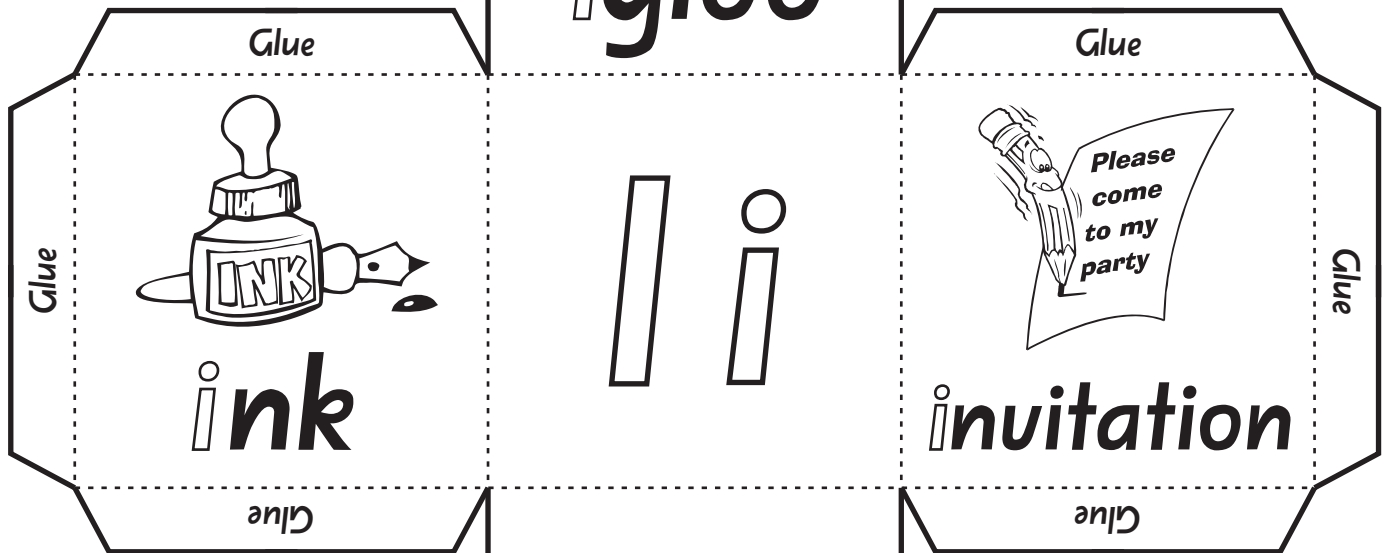
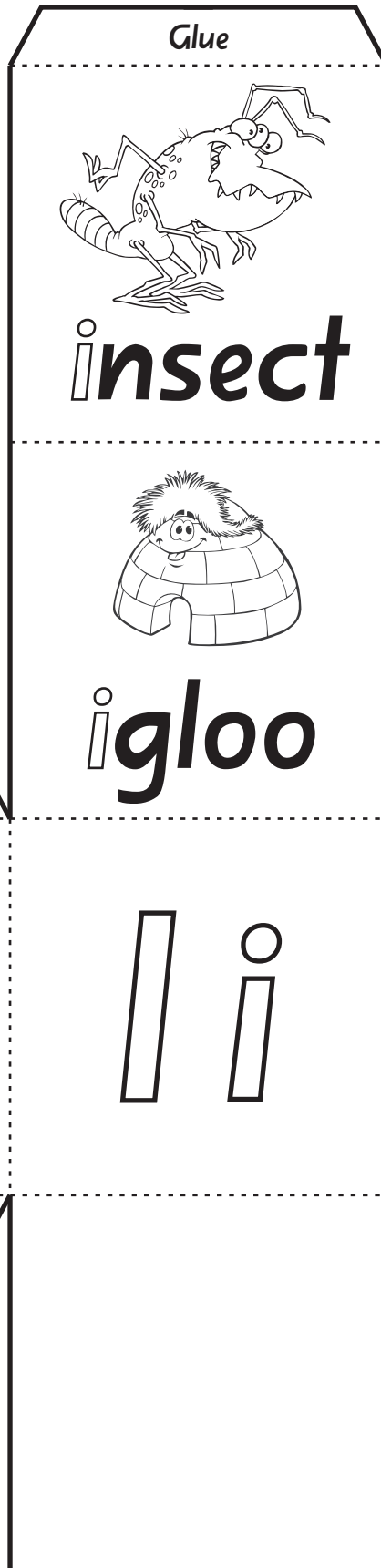
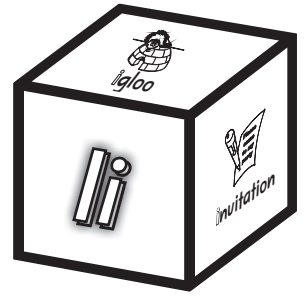

Colour in the big *i* sounds.



Colour the *i* pictures.



Trace over the *i* sounds in the words.



Draw your own *i* picture in the blank square.

Cut along the straight lines and fold along the dotted lines. Glue it together to make a cube.



Trace any i sounds. Colour any picture that starts with i.

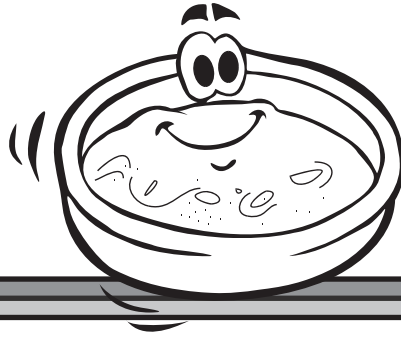
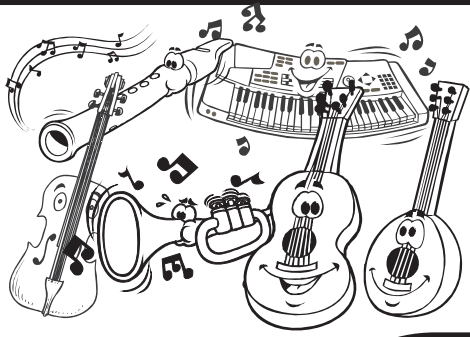

f



i



i



i

ink

i

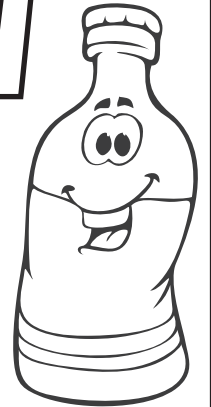

Draw your own i picture.

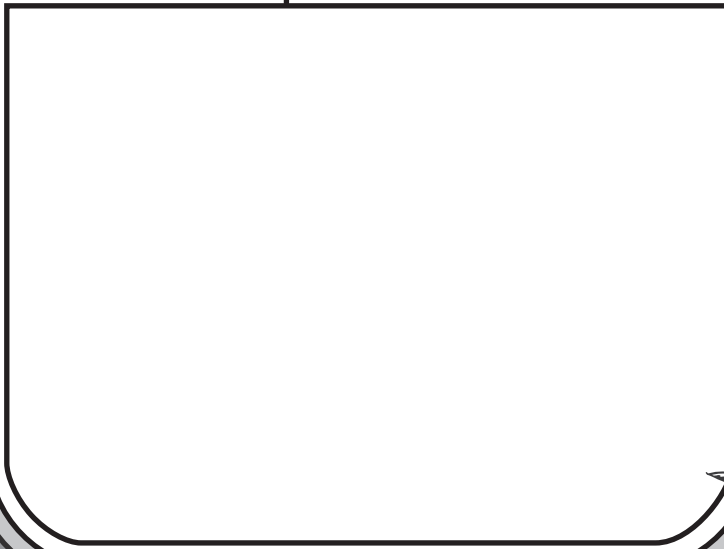

i



i

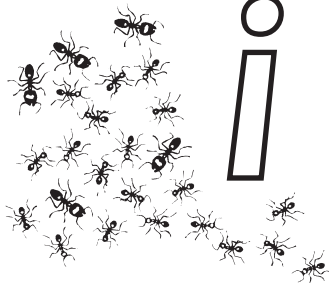

i



i

Draw a line to match the picture and word. Write the sound.



nsects



il

tch



gloo

nk



ndian



Circle the words that start with i.

injection    wheel    invite    in  
on    into    ignore    ink    aim  
it    ill    far    hut    indian

There are  i words.

Colour the pictures that start with i.

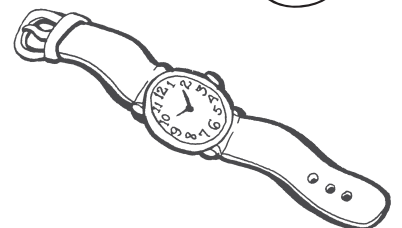
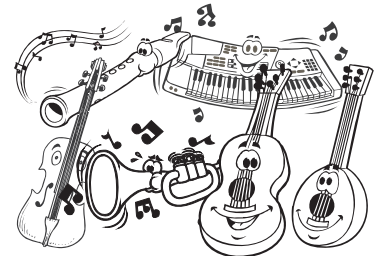

i i



- 1** Write *i* words on the ice bricks of the igloo. Colour the background with chalk.
- 2** Colour the igloo with white crayon and paint over with a light grey wash. When dry use white paint to fingerprint snow in the sky.
- 3** Make a rainbow coloured igloo with brightly coloured bricks. Use cotton wool for snow and clouds.

Trace the j sounds.

	<p>jug</p>

Colour the pictures that start with j.

Trace the jellybeans, colour them and count them.  
Read the sentence and trace the j sounds.

--	--	--

There are ..... jellybeans in the jars.

j J

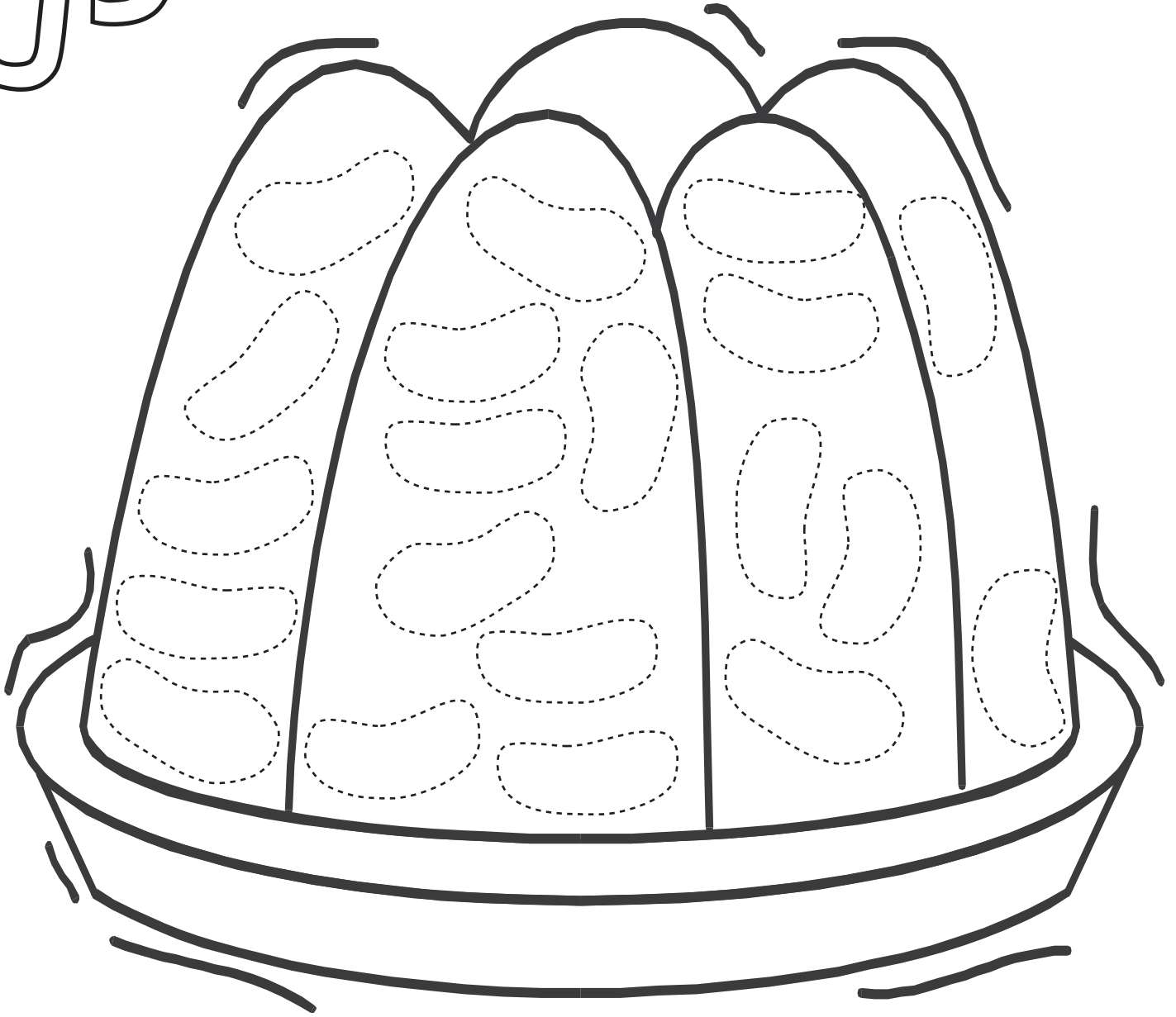

**There are .....jellybeans in the jelly.**

- ☺ Trace over the jellybeans in the jelly and colour them different colours.
- ☺ Count the jellybeans and write the answer in the sentence.
- ☺ Trace over the j sounds.

j J

1. Colour the pictures that start with j.
2. Trace the j words.



jacket



girl

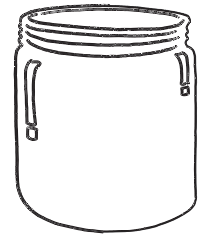

jar



jug

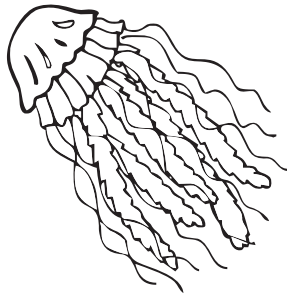

jellyfish

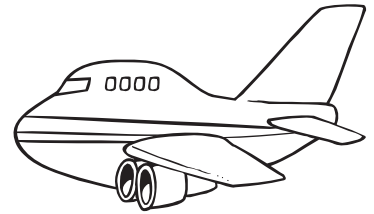

jet



six



jaw

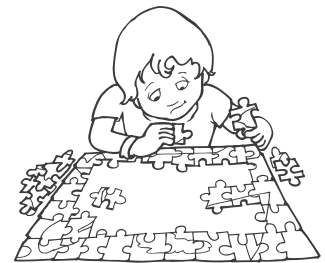

jigsaw

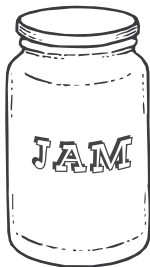

jam



jog



sack

Write some j words on another sheet  
or find some j pictures in magazines or newspapers.

EXTRA  
STUFF



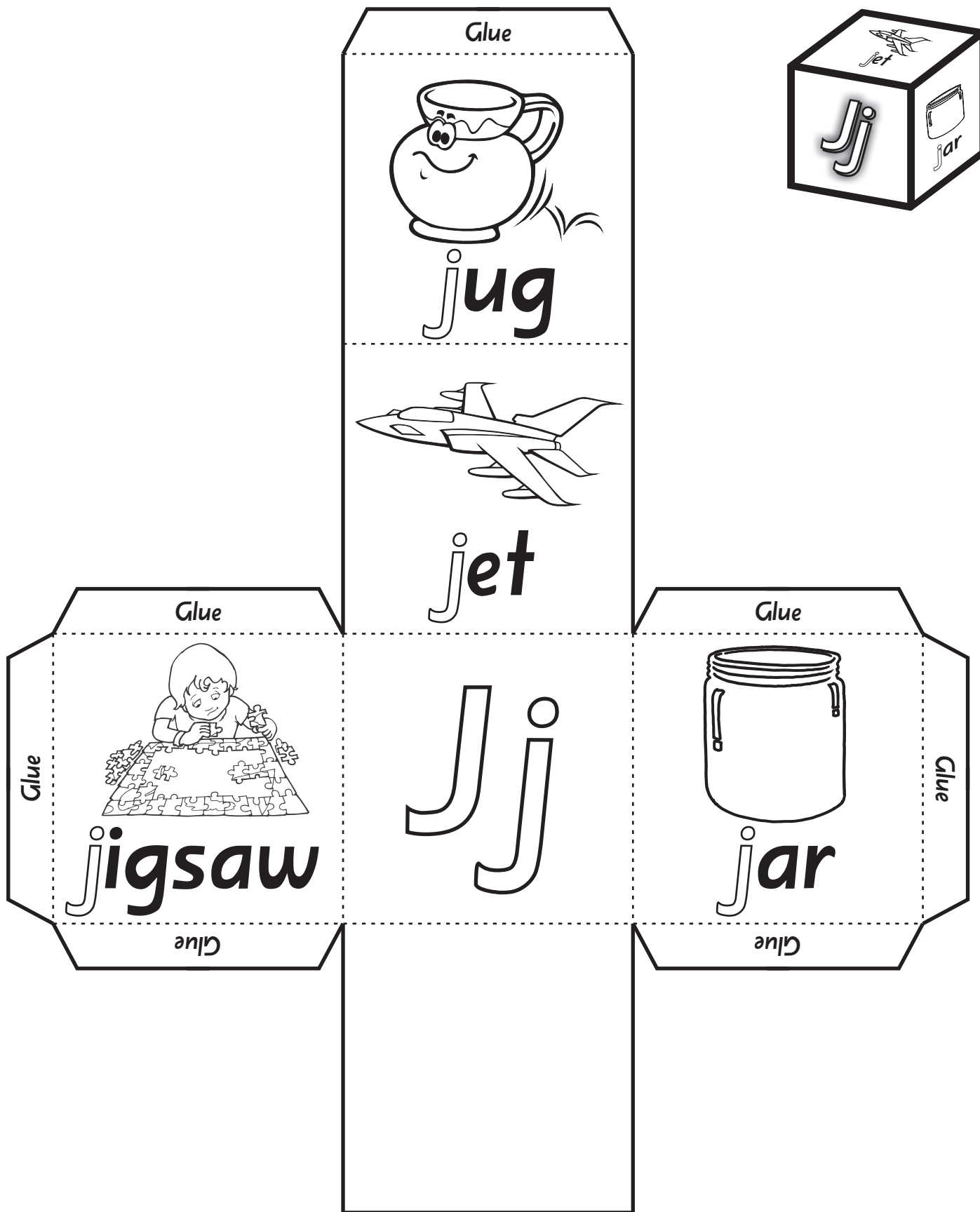

Colour in the big Jj sounds.



Colour the j pictures.



Trace over the j sounds in the words.



Draw your own j picture in the blank square.

Cut along the straight lines and fold along the dotted lines. Glue it together to make a cube.



Trace any j sounds. Colour any picture that starts with j.

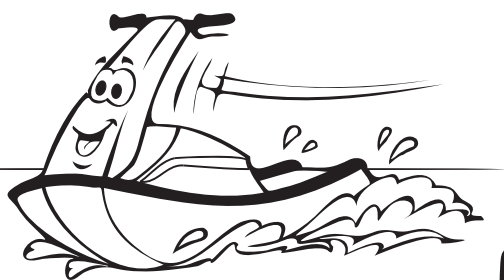

j



p



j

J



jug

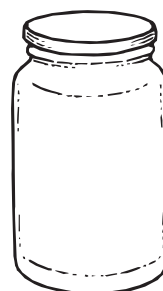

J

J

Draw your own j picture.

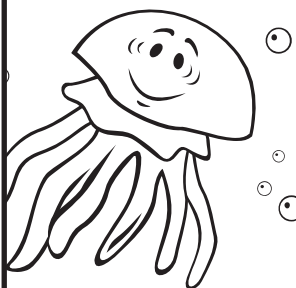
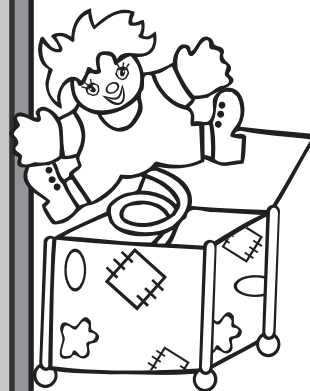
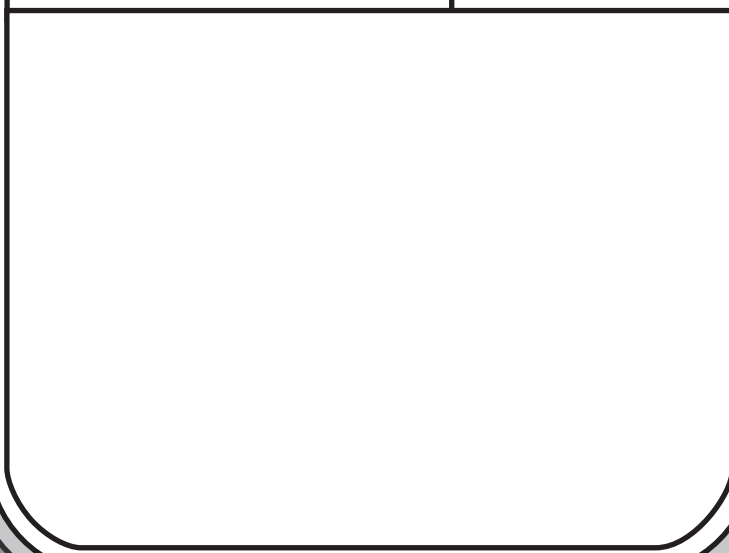

J

i

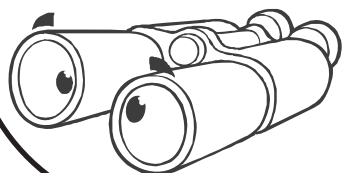

y

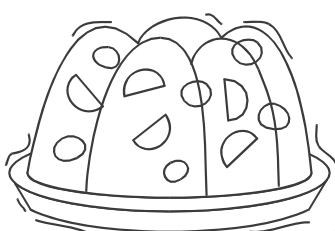

J



j J

Draw a line to match the picture and word. Write the sound.

am

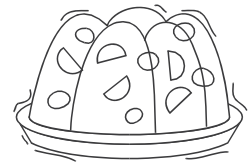

ug

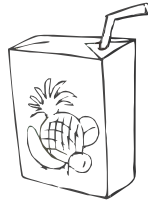

et

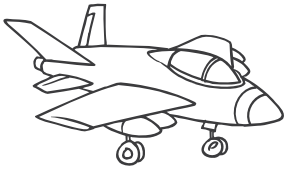
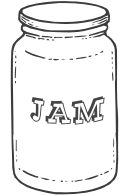

elly

uice

Circle the words that start with j.

job

yoghurt

jump

jog

jug

got

jaw

jab

jam

pod

jig

roar

jockey

There are  j words.

Colour the pictures that start with j.

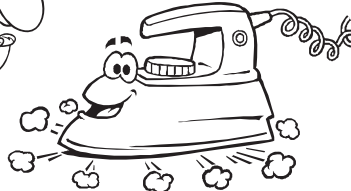
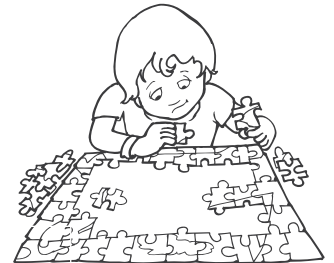
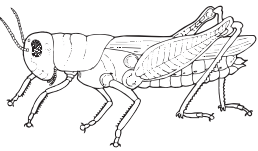

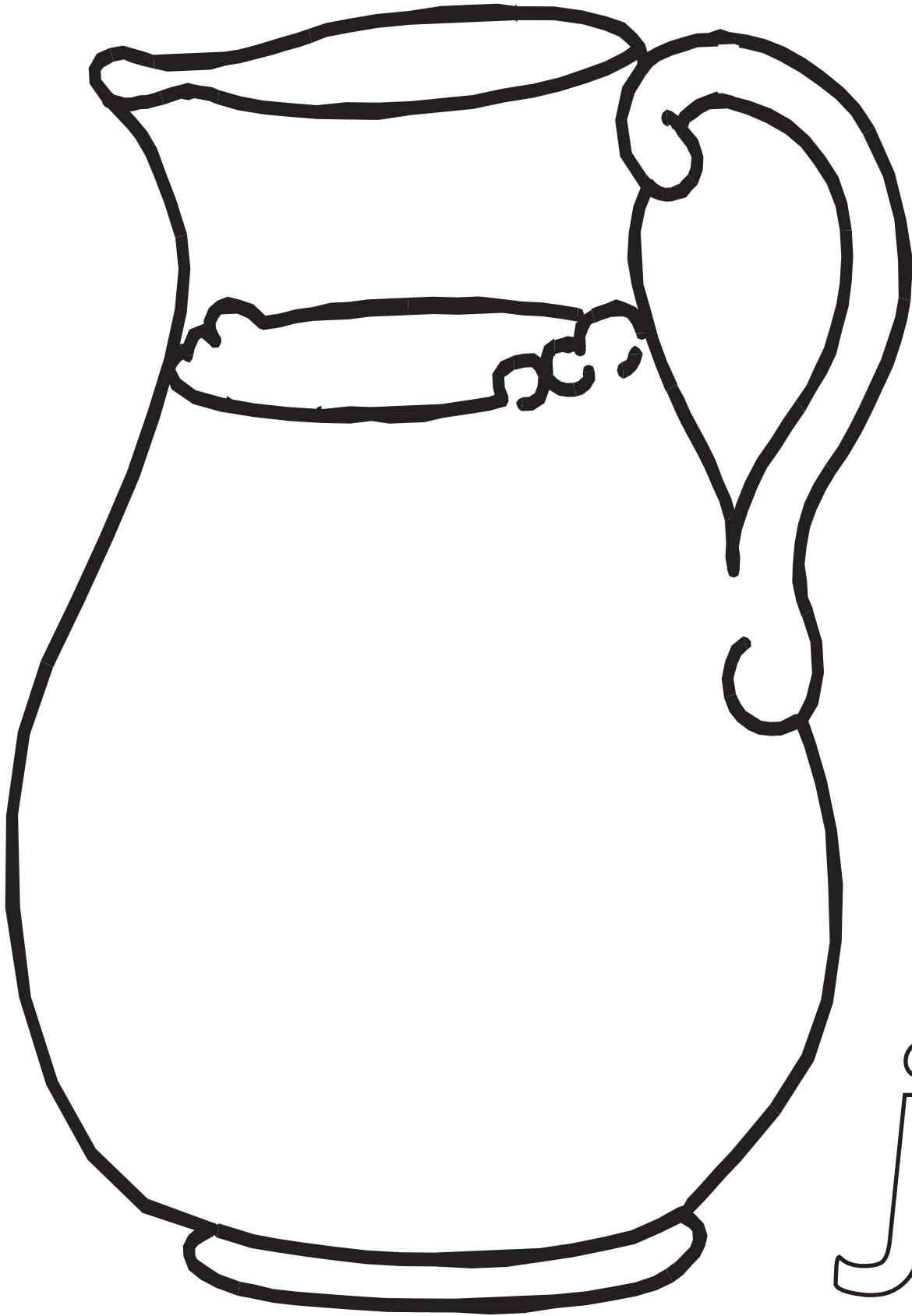

**PICK A  
CRAFT  
IDEA**



- 1** Colour the jug with coloured pencil. Make ice cubes from white paper and write *j* words on each. Paste these inside the jug.
- 2** Fill the jug with thick crayon patterns (no white spaces) using either straight or curved lines. Paint over this with a wash.
- 3** Fill the jug with *j* patterns. Make some cut out glasses and write *j* words in them. Paste the lot together in a large display.

Trace the **k** sounds.

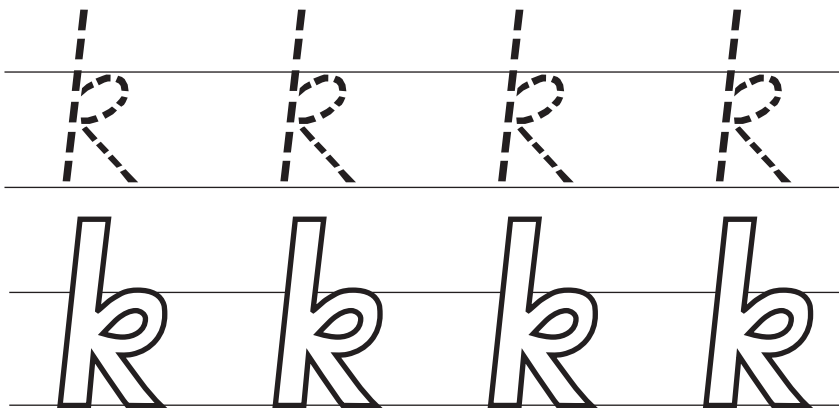

Colour the pictures that start with **k**.

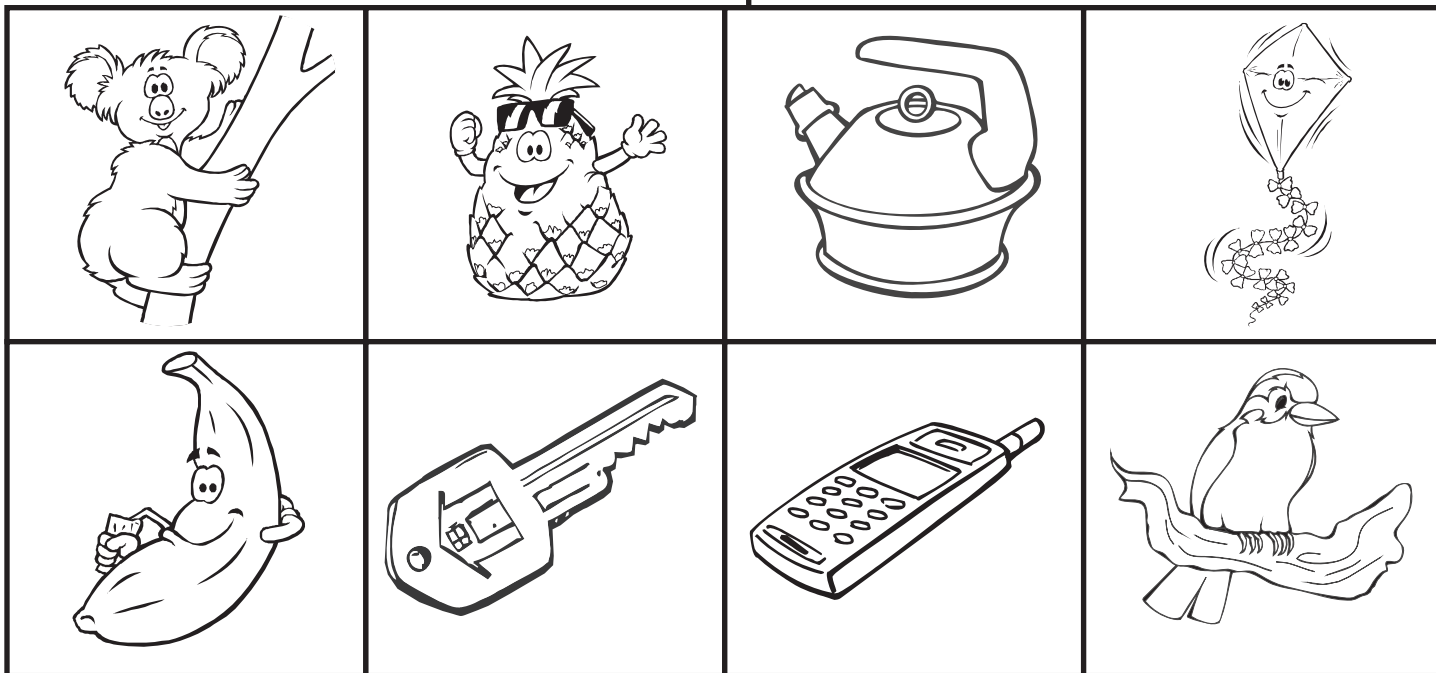

Trace the kites and join them to the kangaroos.  
Read the sentence, write in the numbers and trace the **k** sounds.

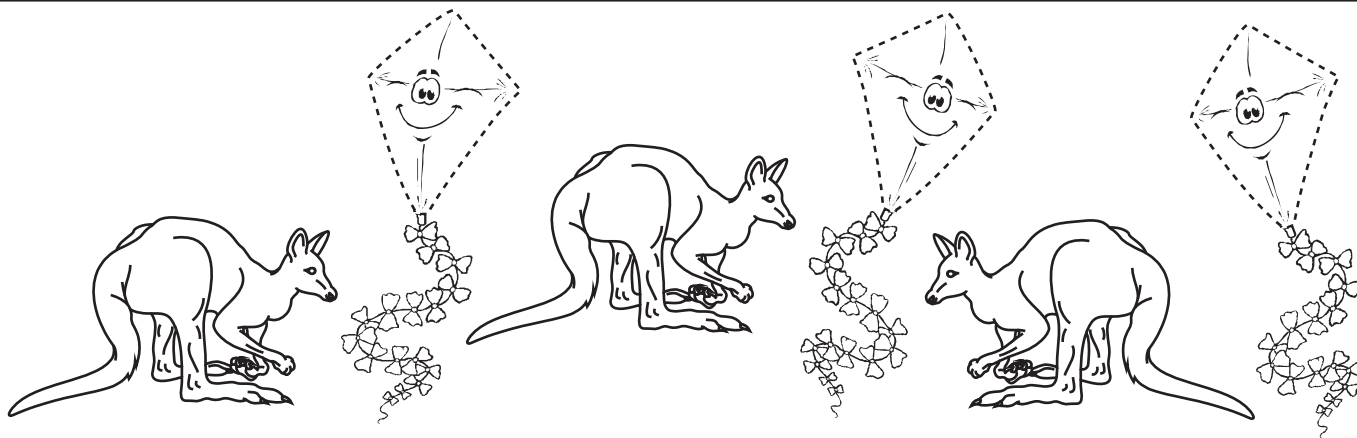

There are .... **k**ites and .... **k**angaroos.

k K

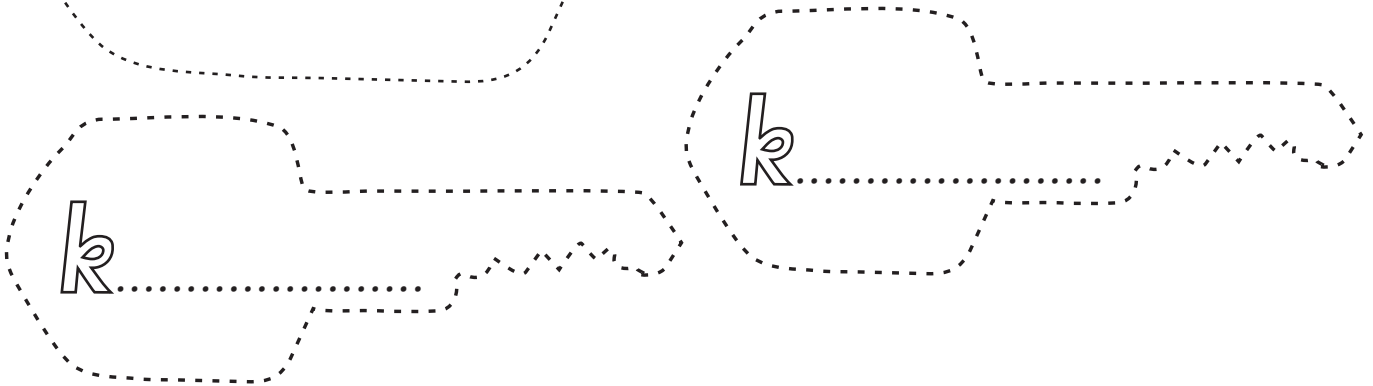
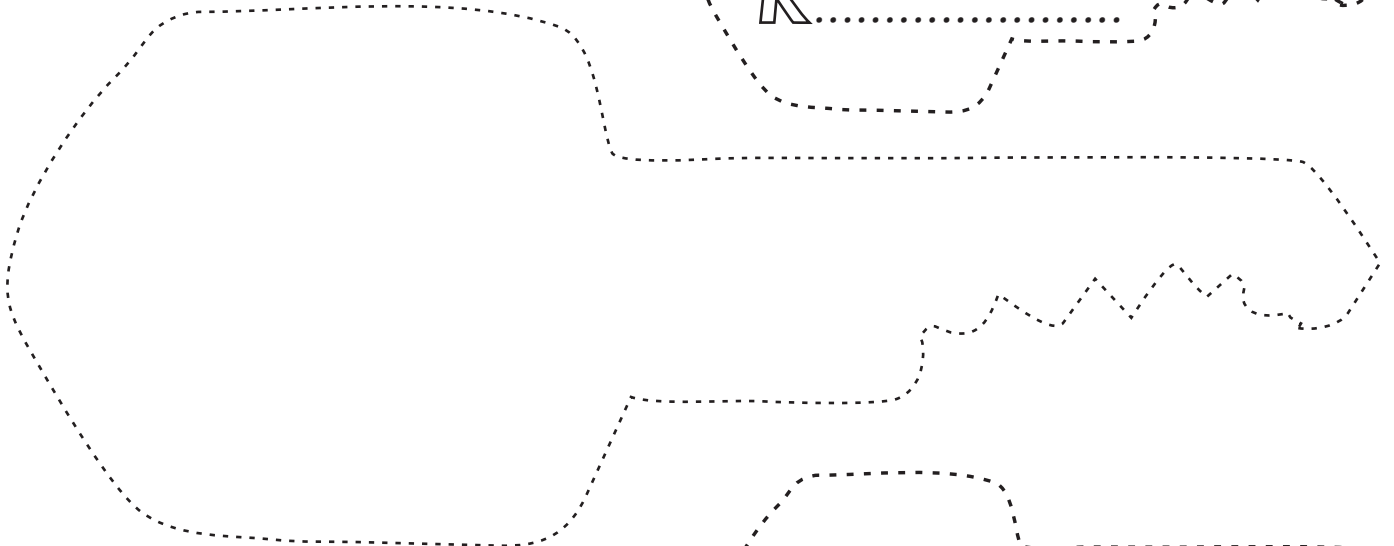
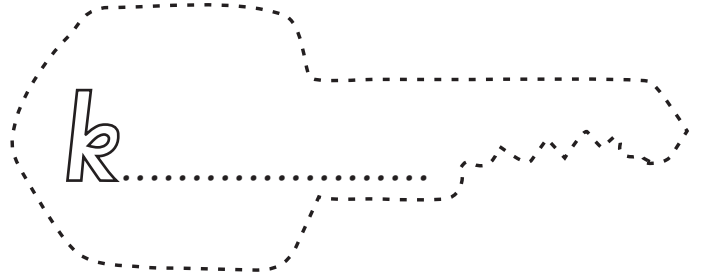
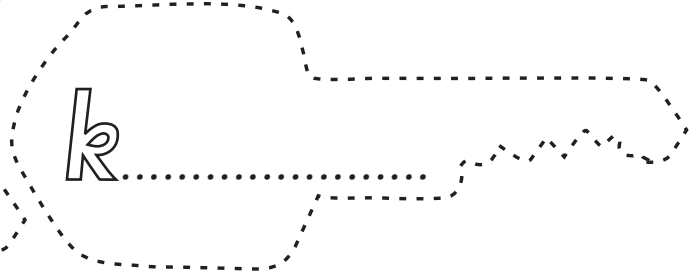
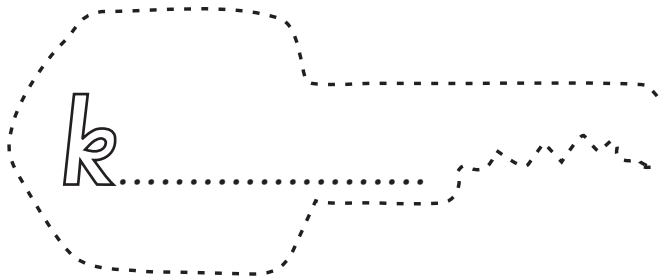
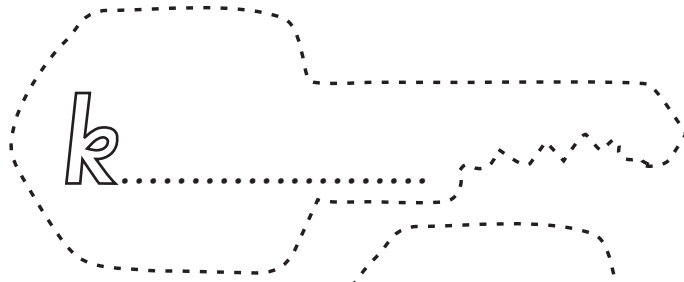

**The big key has a k..... in it.**



Trace around all the keys.



Draw a k thing inside the big key.



Write k words in the small keys.



Colour all the keys and trace over the k sounds.

# kK

1. Colour the pictures that start with **k**.
2. Trace the **k** words.



kangaroo

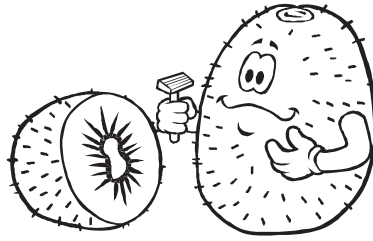

kiwi fruit

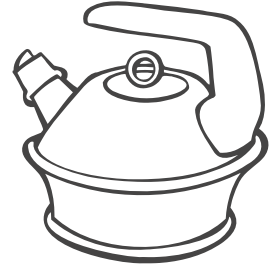

kettle

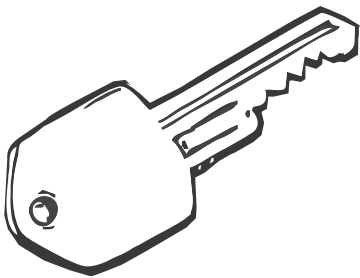

key



mirror

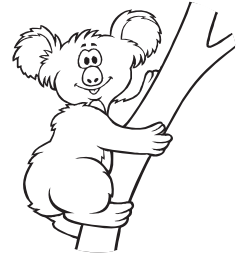

koala

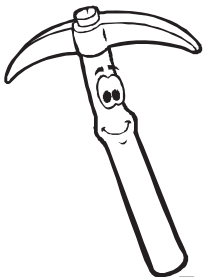

pick



kitten



king

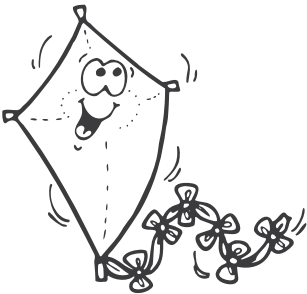

kite



kennel





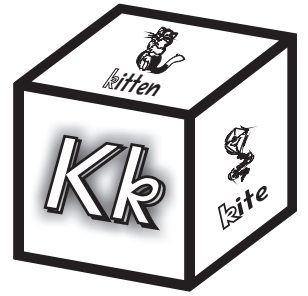

kayak

Write some **k** words on another sheet  
or find some **k** pictures in magazines or newspapers.





-  Colour in the big **Kk** sounds.
-  Colour the **k** pictures.
-  Trace over the **k** sounds in the words.
-  Draw your own **k** picture in the blank square.

Cut along the straight lines and fold along the dotted lines. Glue it together to make a cube.



Trace any **k** sounds. Colour any picture that starts with **k**.

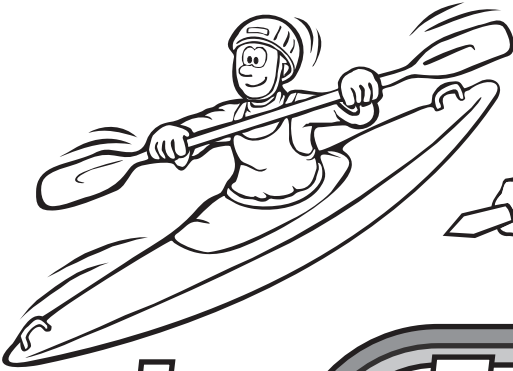

k



k

k

k

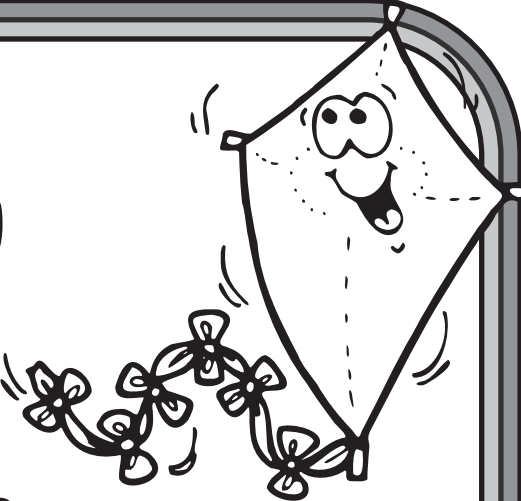
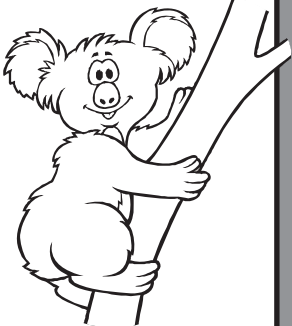

kite

Draw your own **k** picture.

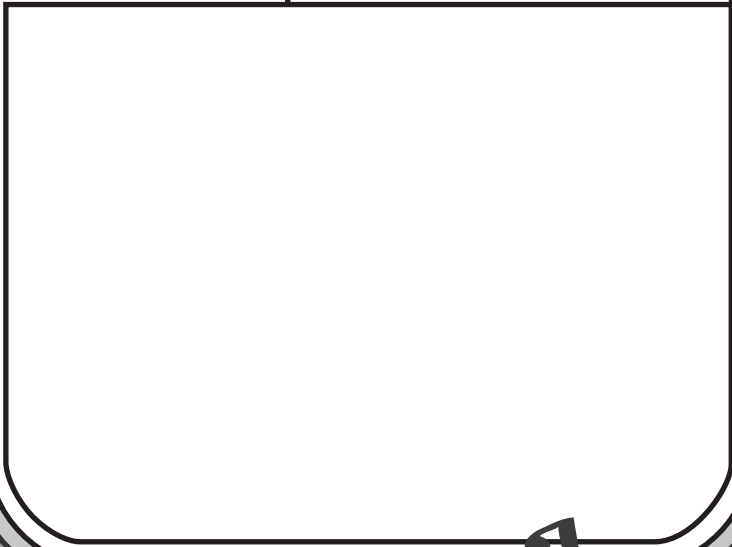

b

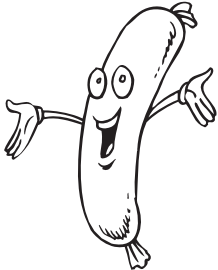
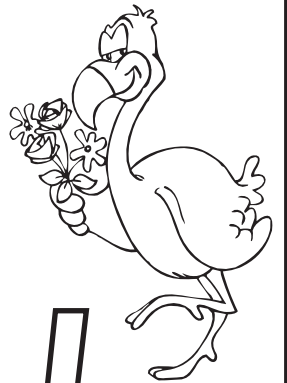

h

k



k



Draw a line to match the picture and word. Write the sound.

k K



ettle

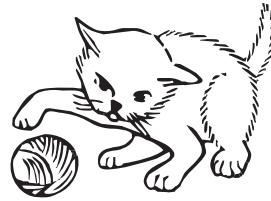

itten

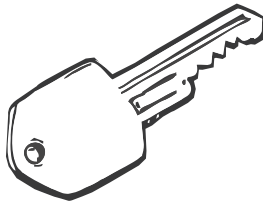

ing

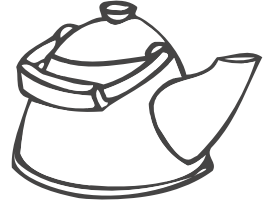

angaroo

ey

Circle the words that start with k.

truck

keep

came

kilt

kept

kill

hill

kid

kick

kelpie

ball

key

kind

kip

There are  k words.

Colour the pictures that start with k.

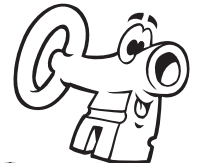
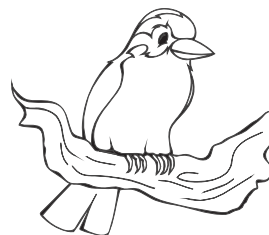
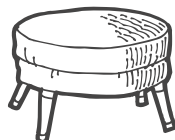
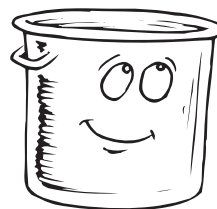
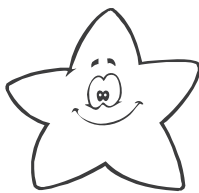

kK

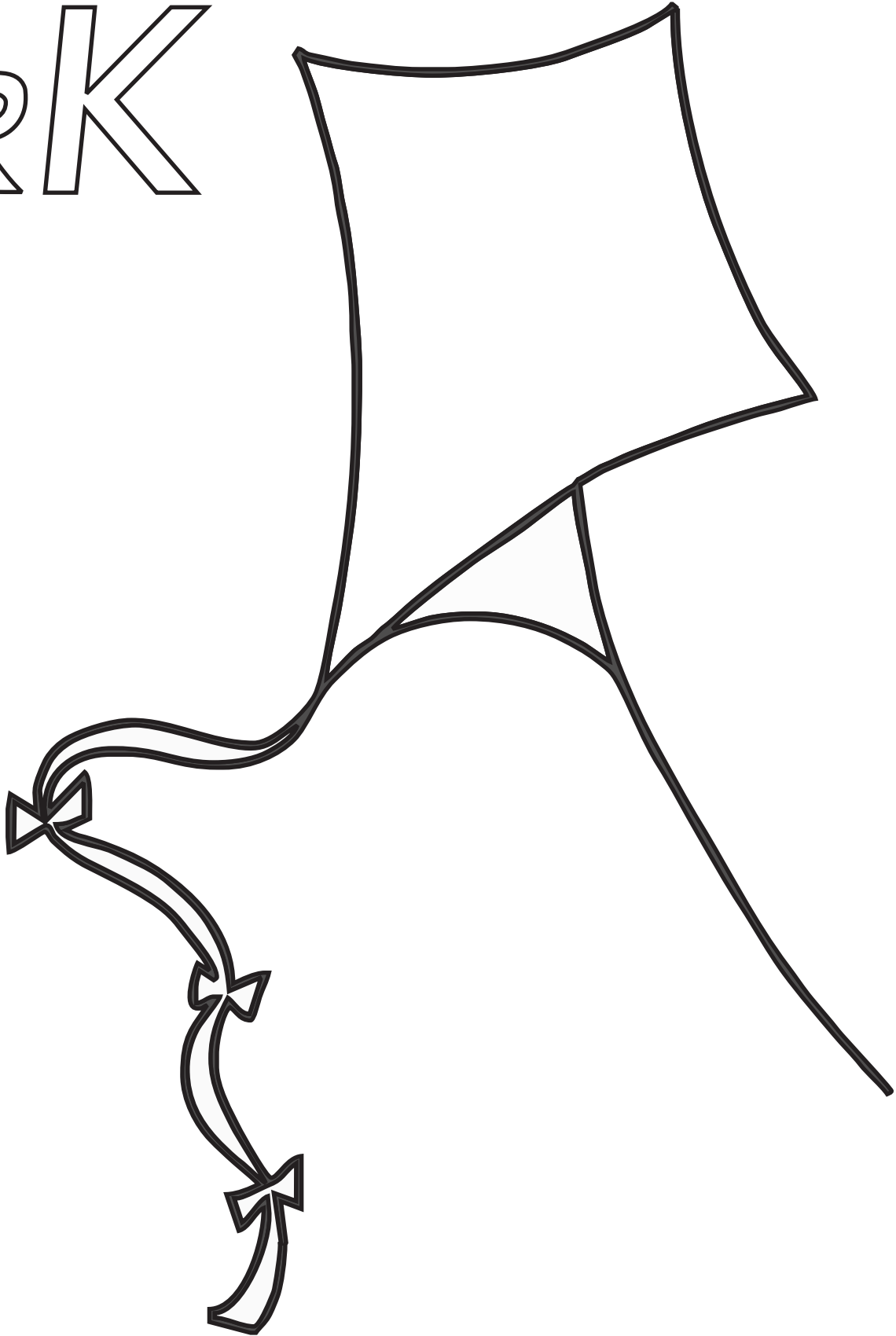

PICK A  
CRAFT  
IDEA



- 1** Colour the kite and use crepe paper for the bows. Draw and colour a person on another sheet of paper. Join both together with string.
- 2** Colour and cut out kites. Write **k** words on each. Mount on a large piece of blue paper with cotton wool clouds for a beautiful **k** display.
- 3** Draw a face on the kite to decorate it then surround each kite with as many **k** words as the student can think of.

Trace the | sounds.

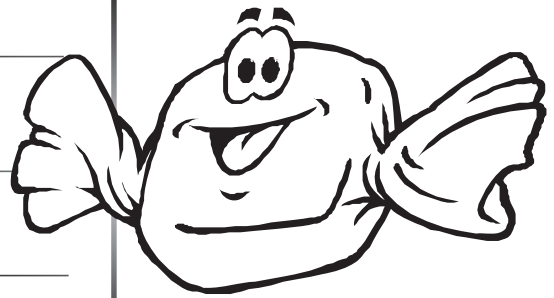
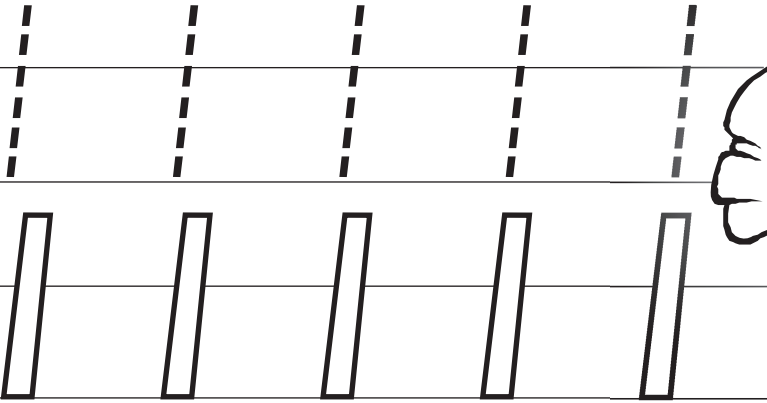

|olly

Colour the pictures that start with |.

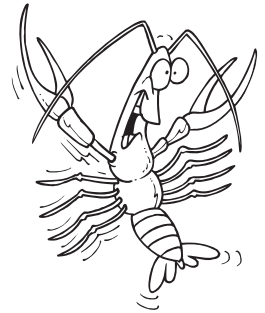
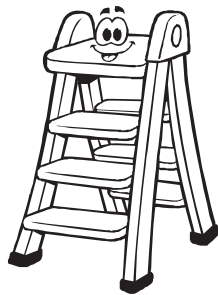
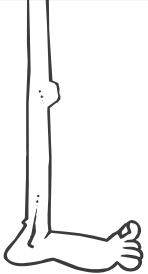
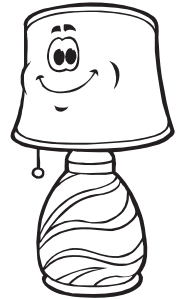
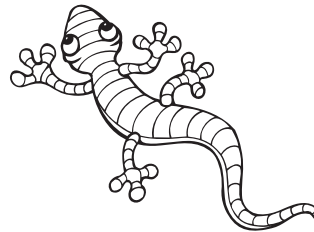
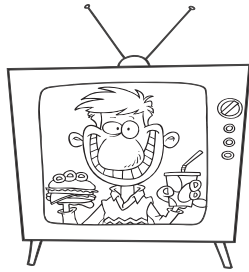

Trace the leaves and colour in the ladybeetles.  
Read the sentence and trace the | sounds.

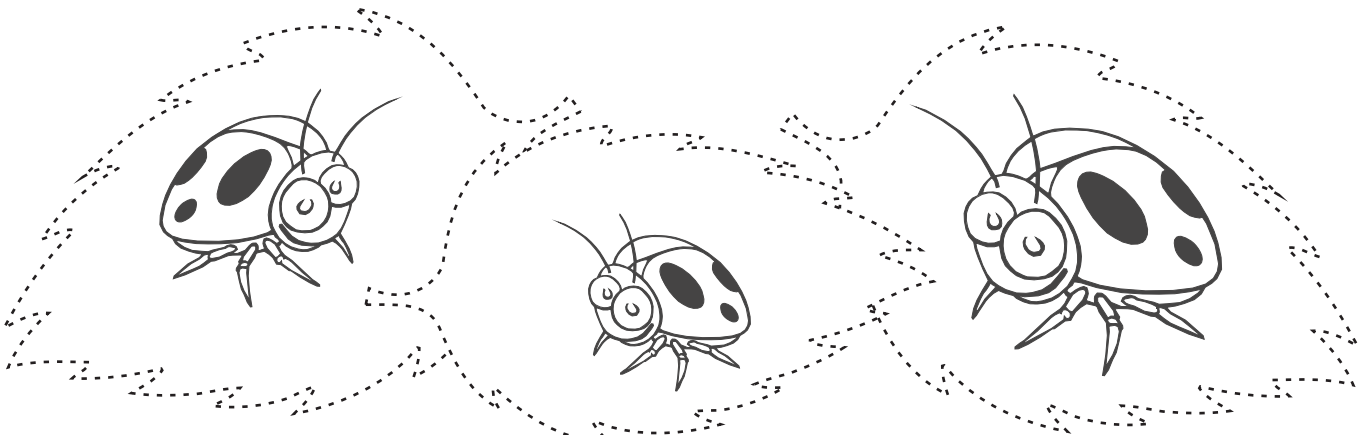

Ladybeetles |ike |eaves.

l l

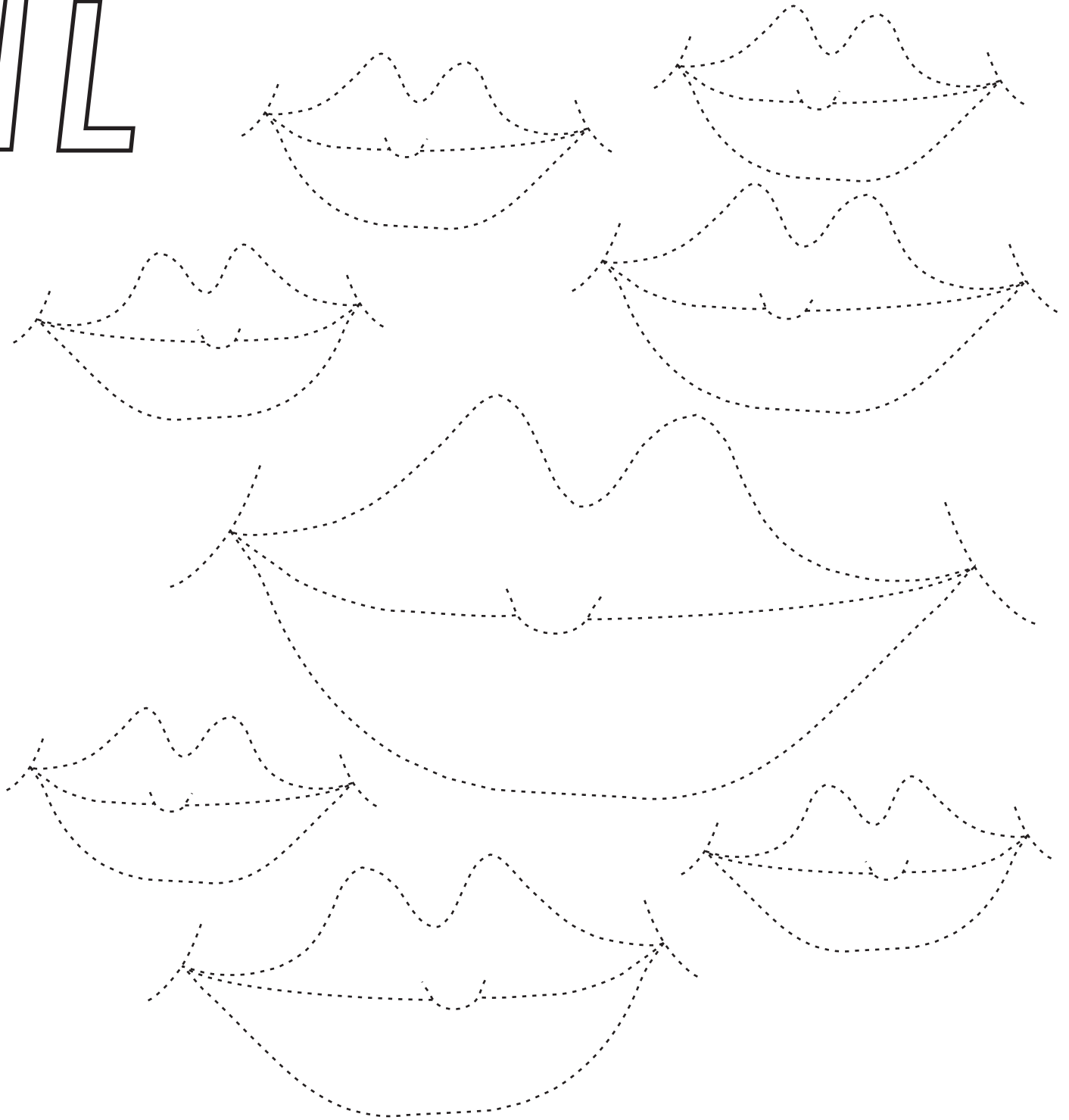

**There are l lots of l lips.**

- ☺ Trace over the lip shapes and colour them in.
- ☺ Inside each one draw a picture of something starting with l or cut out pictures from magazines e.g. lolly, ladder, lemon, legs, lion etc.
- ☺ Trace over the l sounds in the sentence.

# l

1. Colour the pictures that start with l.
2. Trace the l words.



lion



carrot

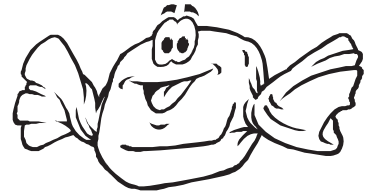

lolly



lamp



leaf

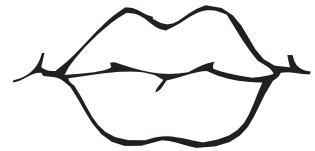

lips

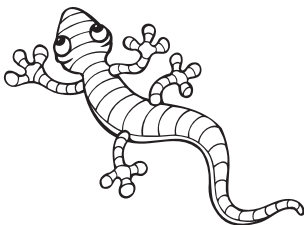

lizard



letter

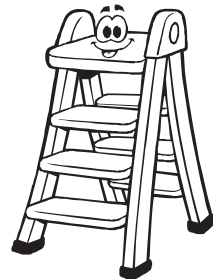

ladder

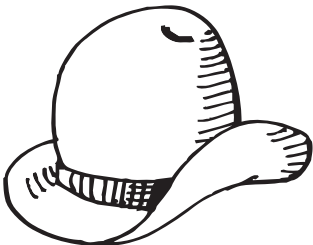

hat

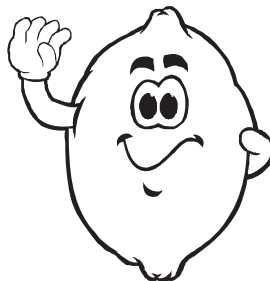

lemon

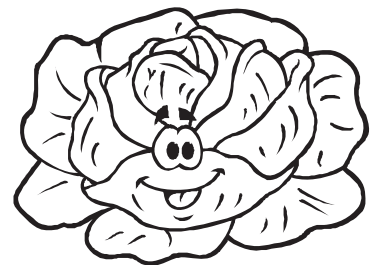

lettuce

Write some l words on another sheet  
or find some l pictures in magazines or newspapers.



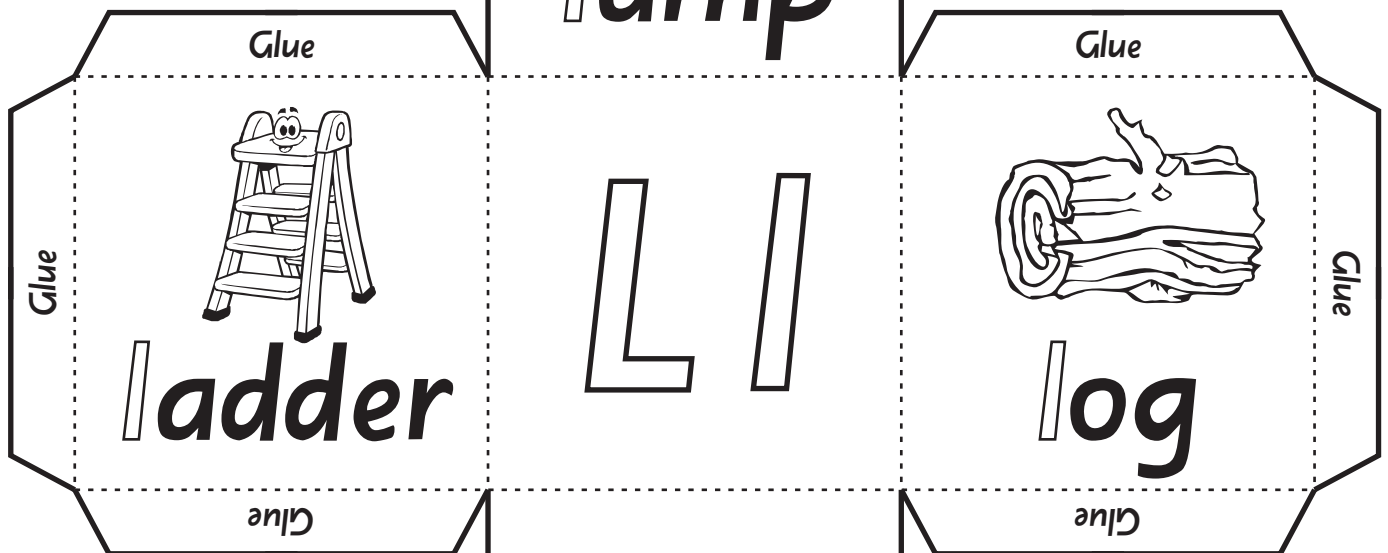
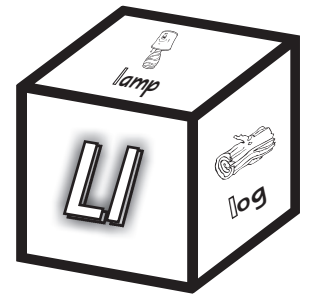
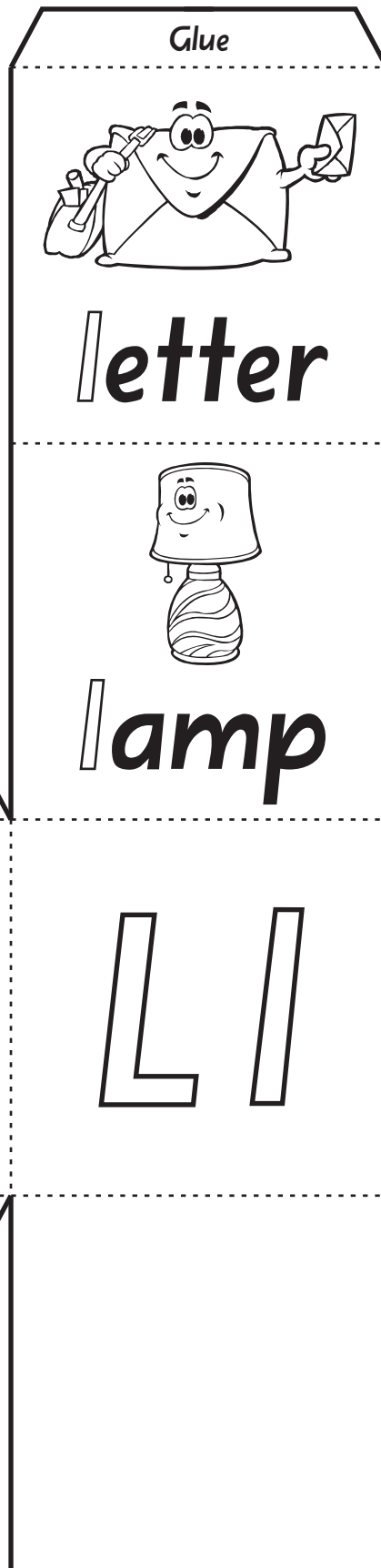

- ☺ Colour in the big L| sounds.
- ☺ Colour the | pictures.
- ☺ Trace over the | sounds in the words.
- ☺ Draw your own | picture in the blank square.

Cut along the straight lines and fold along the dotted lines. Glue it together to make a cube.



Trace any l sounds. Colour any picture that starts with l.

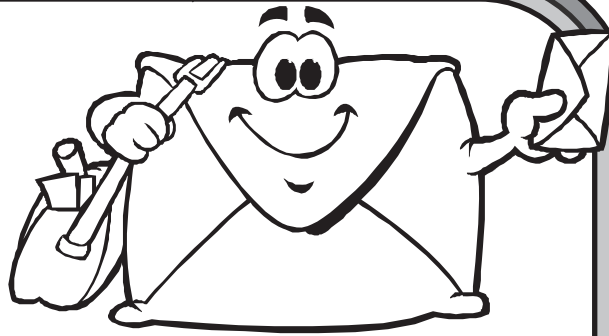
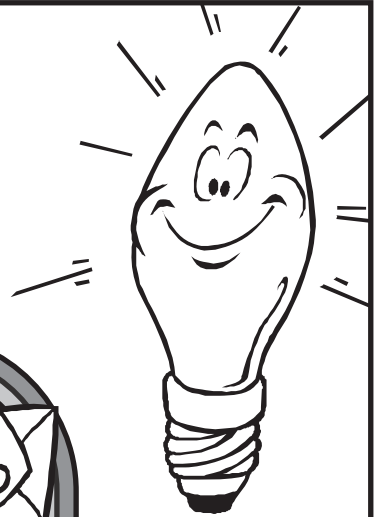
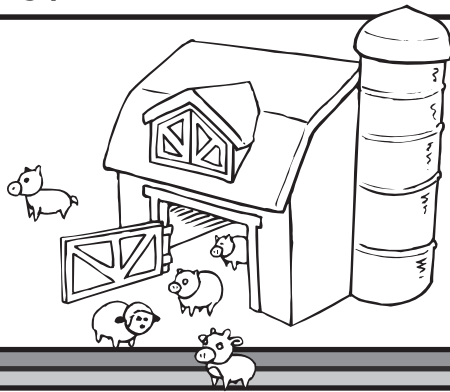
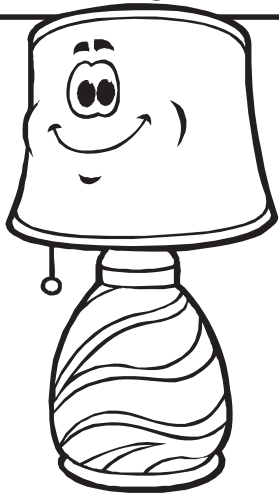

letter

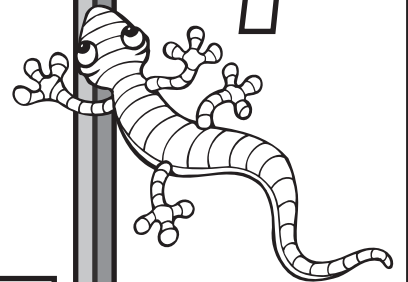

Draw your own l picture.

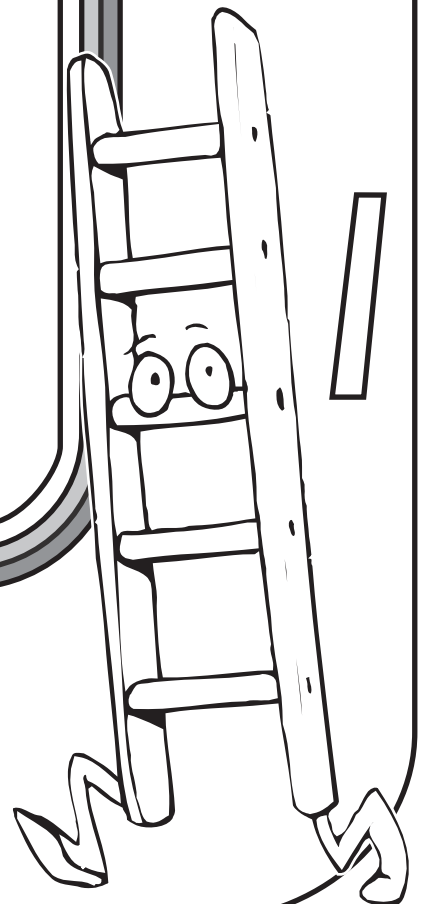
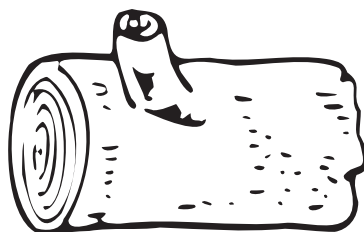
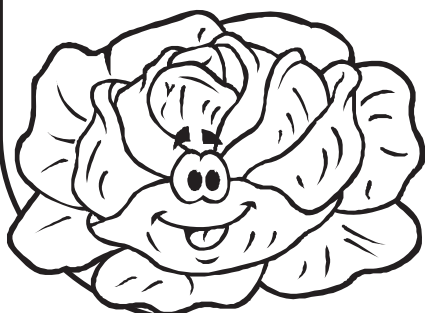
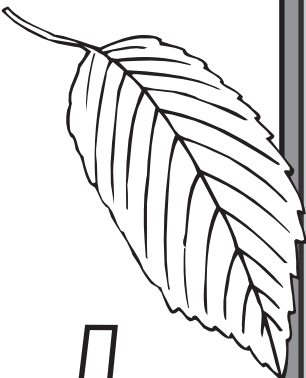
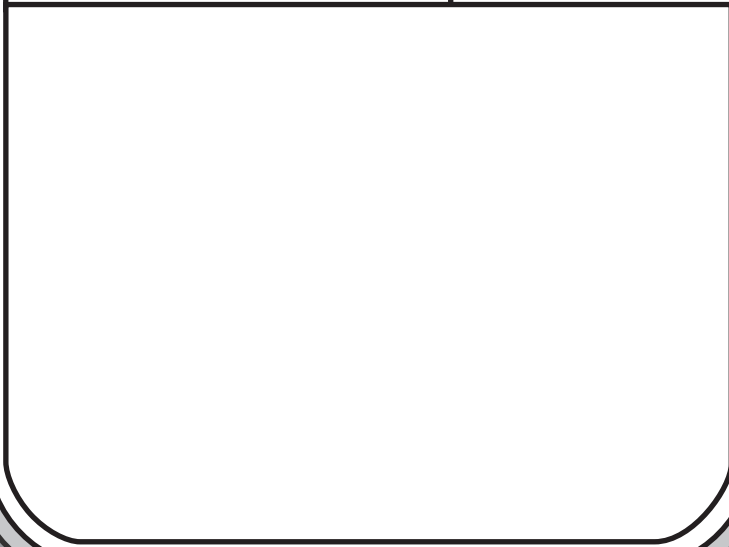

ll

Draw a line to match the picture and word. Write the sound.

lid



lamp

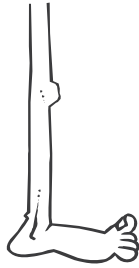

lips

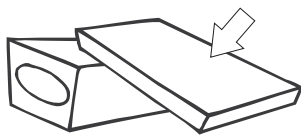
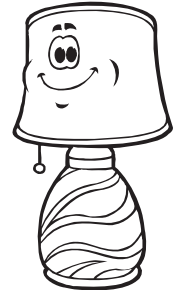

log

leg

Circle the words that start with l.

lip top long lady like  
happy look lap lunch  
melon lemon lift lead

There are  l words.

Colour the pictures that start with l.

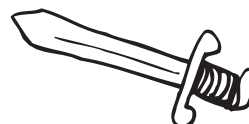
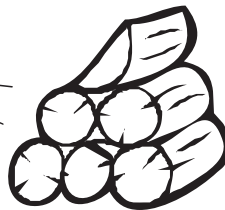
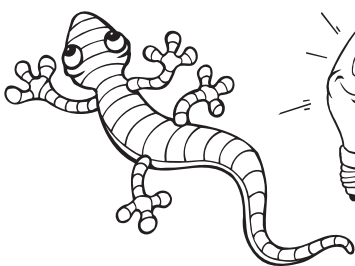

IL

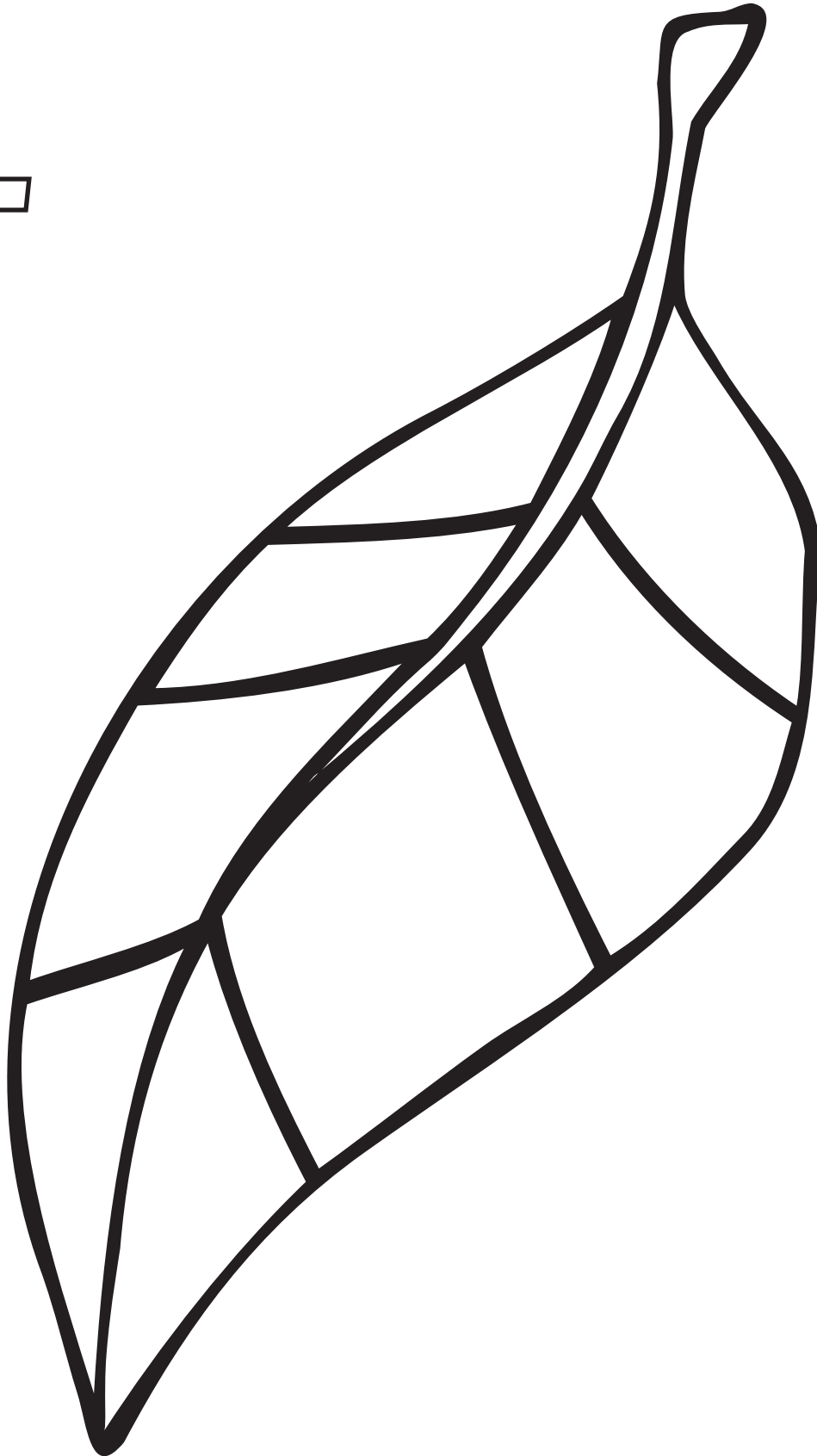

PICK A  
CRAFT  
IDEA



- 1** Paint a large tree trunk and branches. Paint the leaves and when dry add markings with crayons. Cut out and paste onto the large tree.
- 2** Write **l** words on the leaf segments. Shade the leaves in autumn colours and paste them onto a large class tree or an actual tree branch in a pot.
- 3** Paint leaves and when dry cut out and paste around the edges of coloured paper. Inside this frame paste pictures of objects that begin with **l**.

Trace the *m* sounds.

m

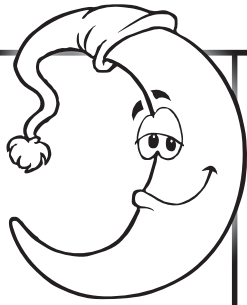

moon

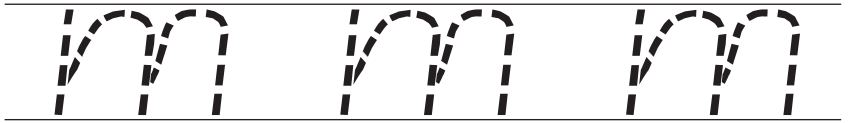

Colour the pictures that start with *m*.

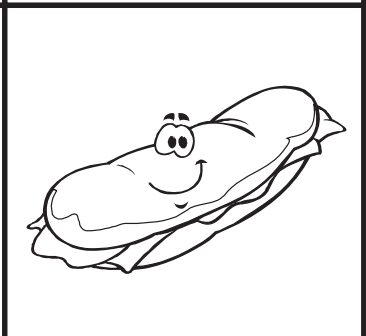
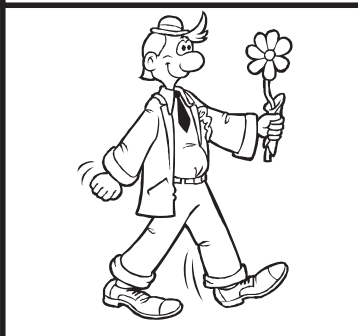
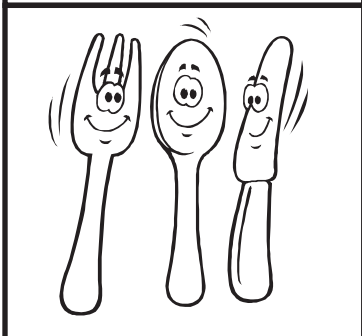
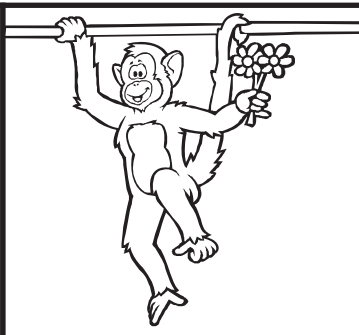
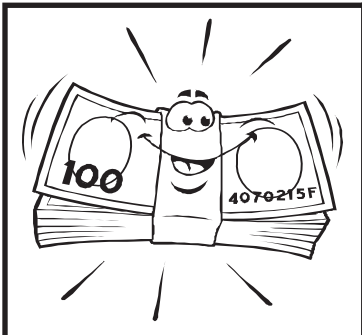

Trace a path from the mouse to the cheese.  
Read the sentence and trace the *m* sounds.

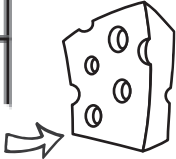
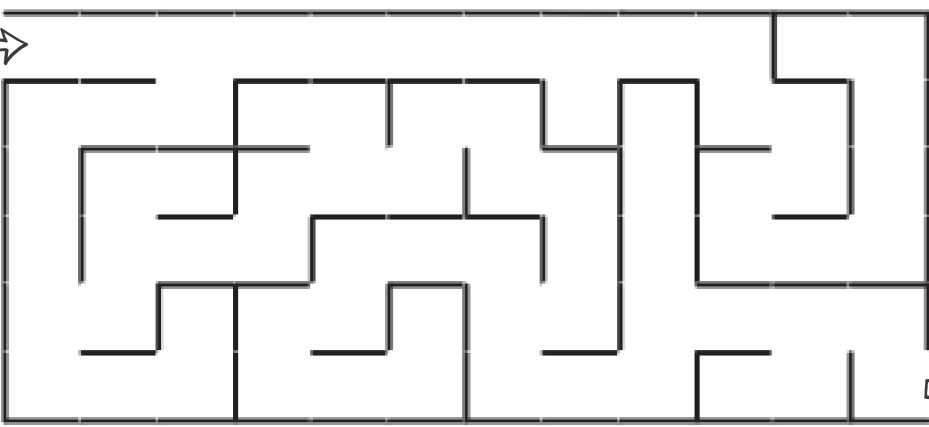



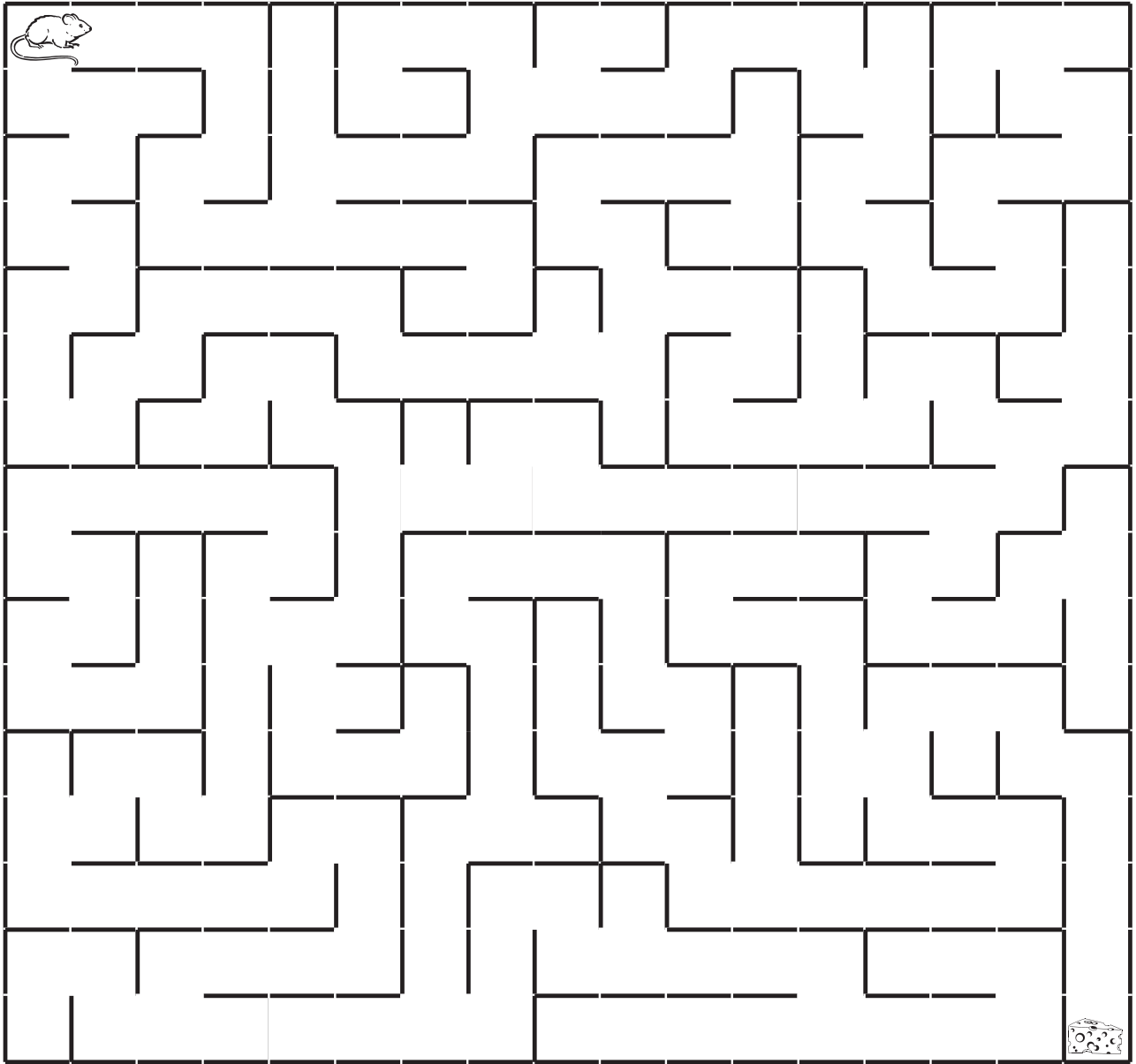

The *m*ouse goes through the *m*aze.

m M



**The *m*ouse went through  
the *m*aze to the cheese.**

-  Trace a path from the mouse to the cheese.
-  Colour the mouse and the cheese.
-  Trace over the *m* words in the sentence.
-  Can you draw a maze of your own?

# mM

1. Colour the pictures that start with *m*.
2. Trace the *m* words.

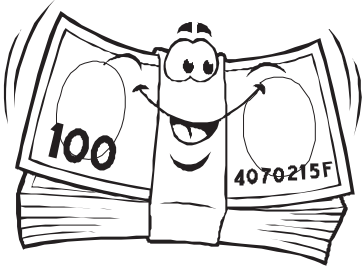

money



monkey

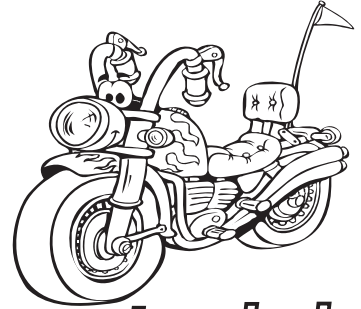

motorbike

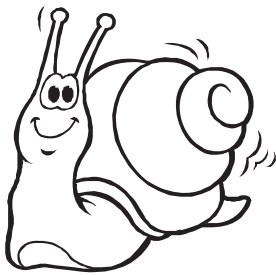

snail

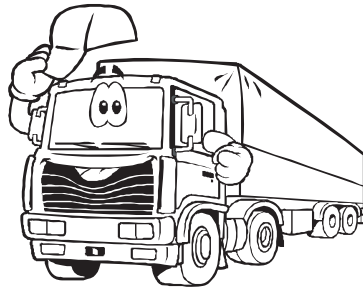

truck

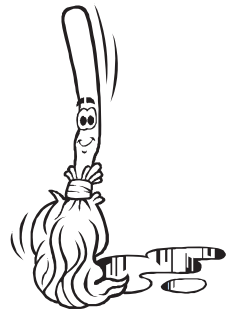

mop

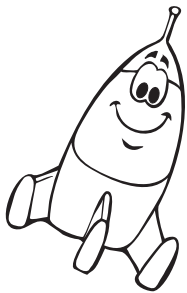

rocket

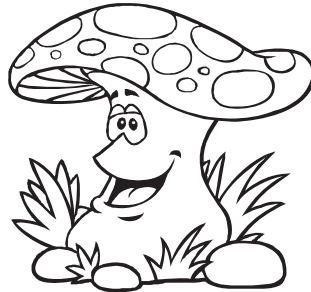

mushroom



mow



mouse



moon



mug

Write some *m* words on another sheet  
or find some *m* pictures in magazines or newspapers.



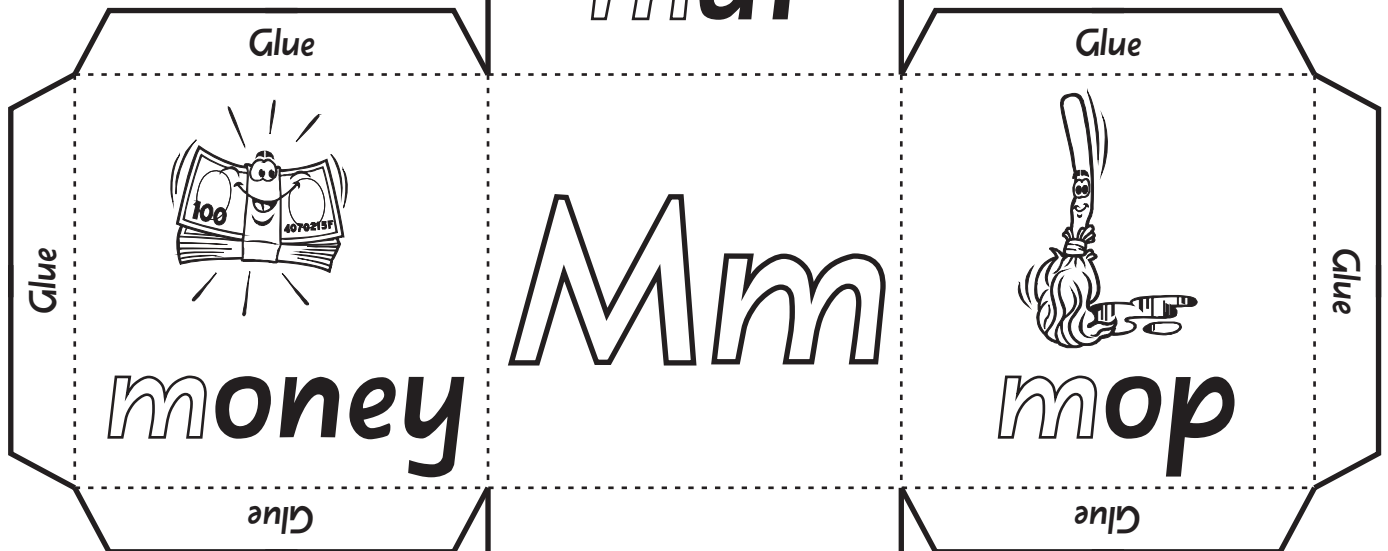
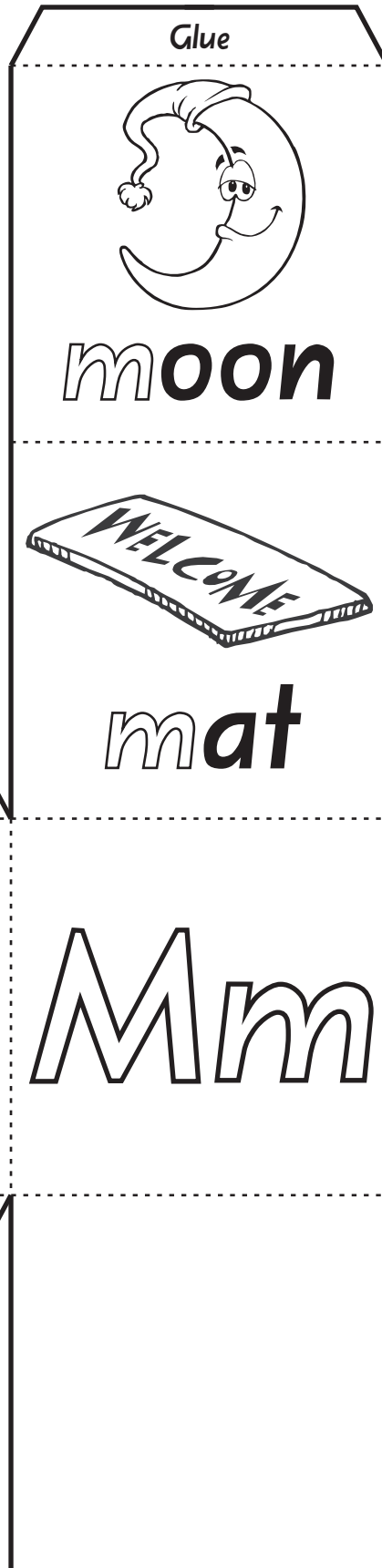
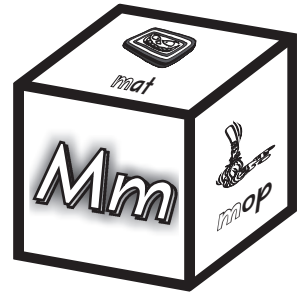

Colour in the big *Mm* sounds.



Colour the *m* pictures.



Trace over the *m* sounds in the words.



Draw your own *m* picture in the blank square.

Cut along the straight lines and fold along the dotted lines. Glue it together to make a cube.



Trace any m sounds. Colour any picture that starts with m.

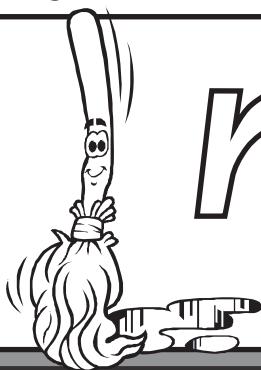
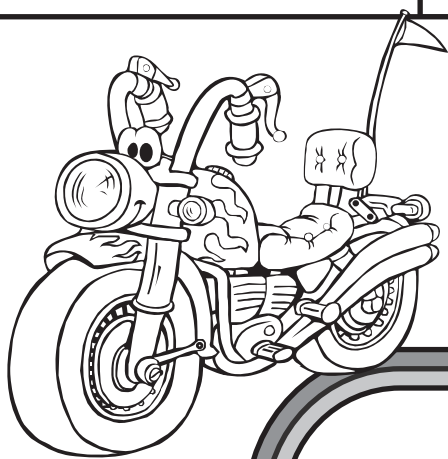

m



m

m

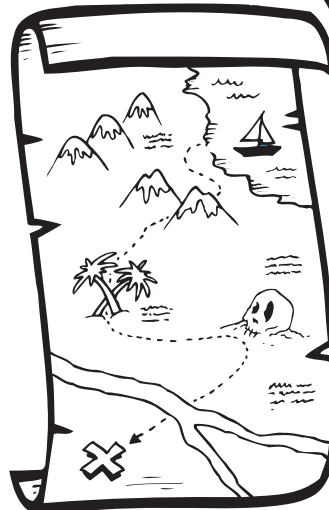

m

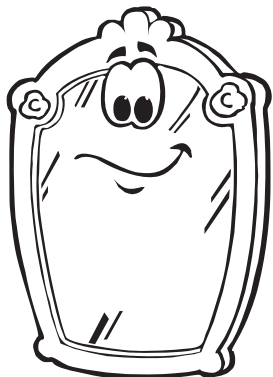

map

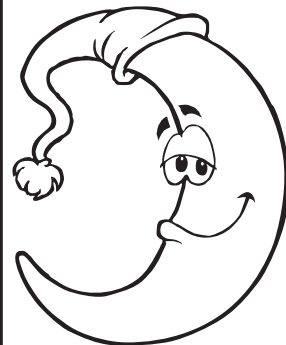

Draw your own m picture.

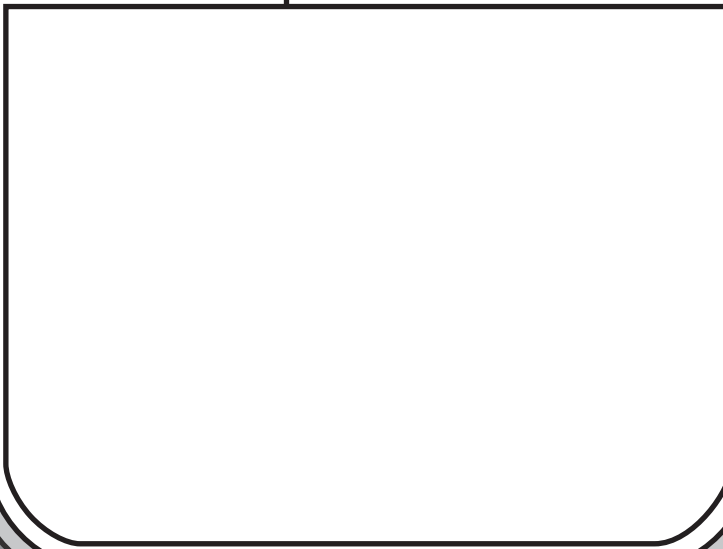

m

n

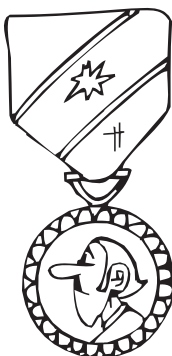

m

m

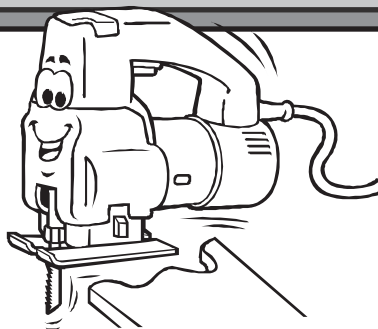
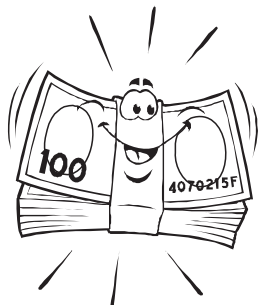

h

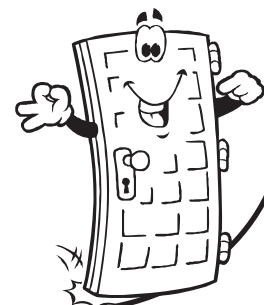

Draw a line to match the picture and word. Write the sound.

m M



□ op

□ um

□ ouse

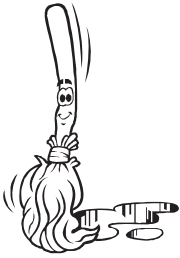

□ an



□ at

Circle the words that start with m.

mug    nut    milk    top    me  
 not    my    mother    mud  
 monster    men    hen    mow

There are  m words.

Colour the pictures that start with m.

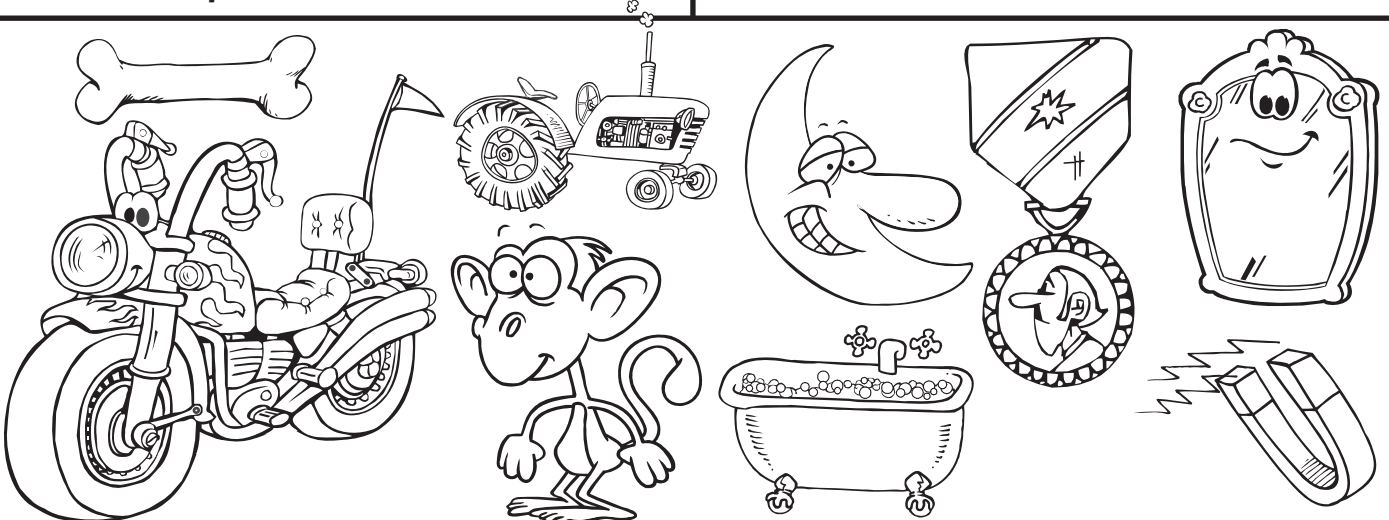

mM

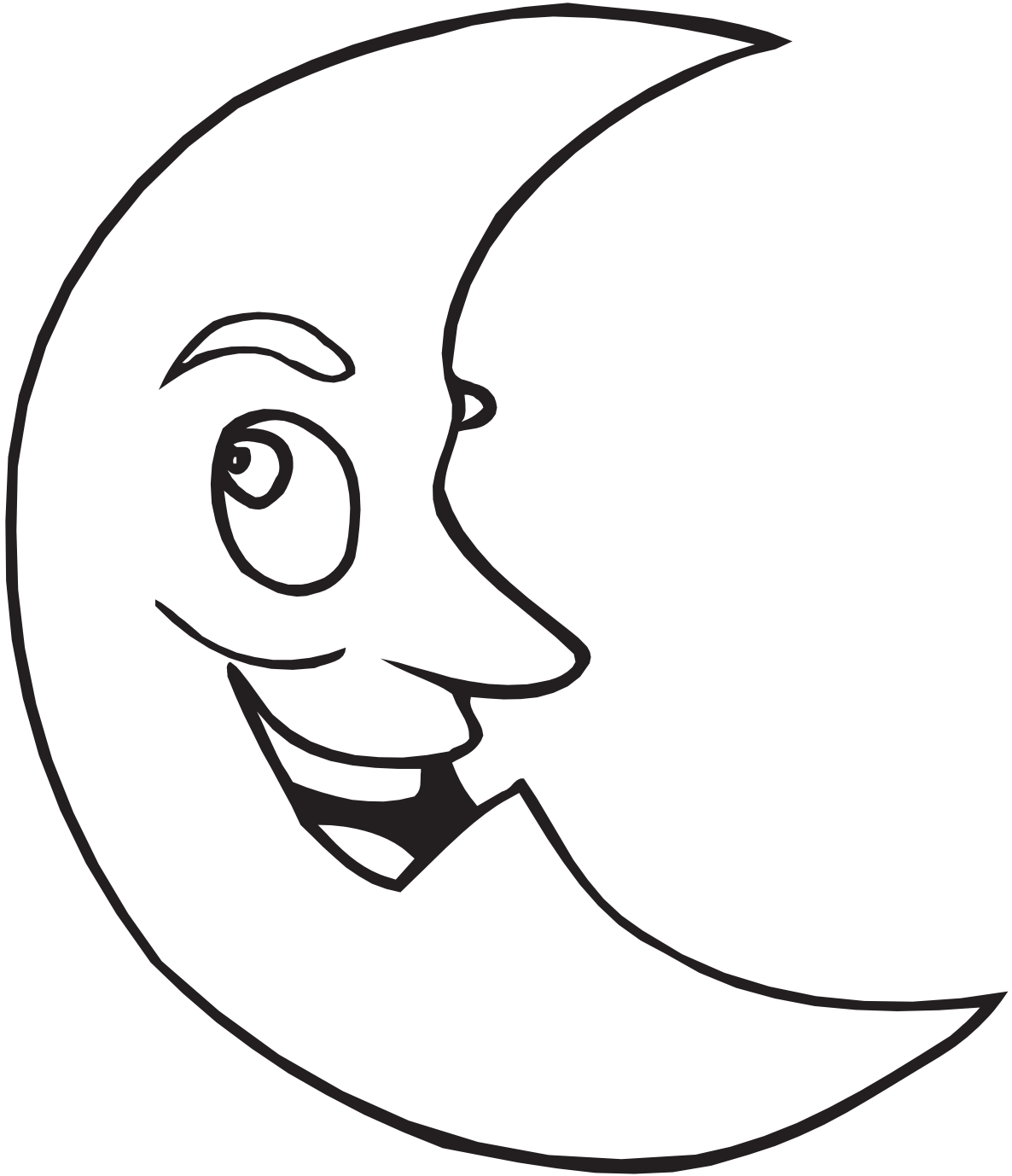

PICK A  
CRAFT  
IDEA



- 1** Make a night time picture. Draw buildings etc with crayon and apply a black wash. Colour the moon yellow and paste into the night sky.
- 2** Cut out two moons and paste back to back with string in between to make a mobile. Write *m* words on the moons and colour them yellow.
- 3** Colour the moon and paste it onto a large display sheet. Surround this with stars and planets that have *m* words written on them.

Trace over the n sounds.

n n n n

n n n n



n

nail

Colour the pictures that start with n.

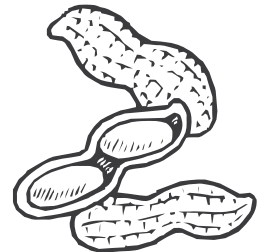
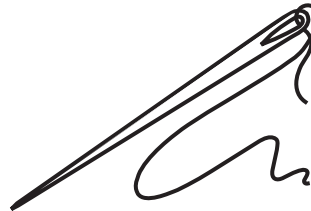
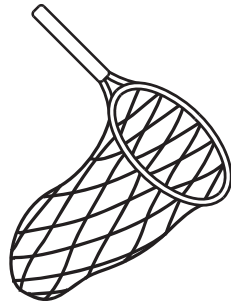

Draw nine birds in the nest and colour the picture.  
Read the sentence and trace the n sounds.



Nine birds in a nest.

n N

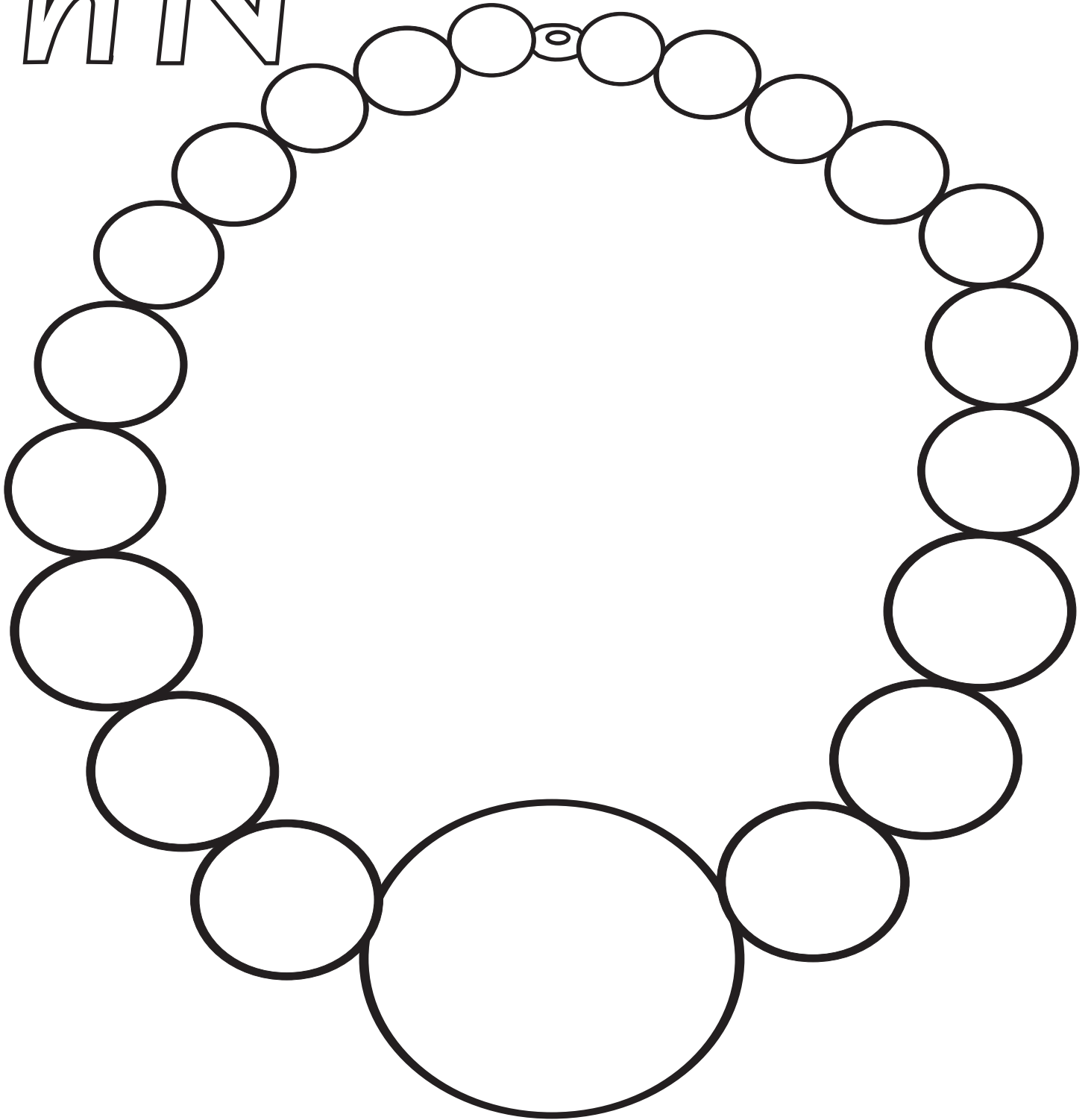

*Nan has a nice necklace.*



*Colour the necklace or put glue on the necklace beads and sprinkle different coloured glitter on them.*



*Trace over the n sounds in the sentence.*

# n N

1. Colour the pictures that start with n.
2. Trace the n words.



bell



nun



nest



nose



rain

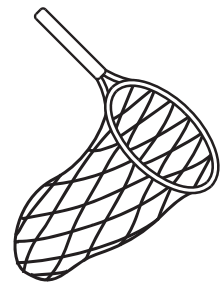

net



nurse



nail



newspaper

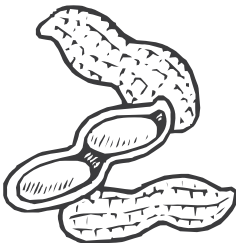

nuts

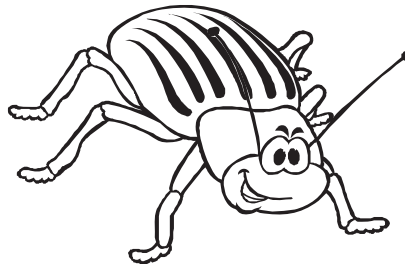

beetle

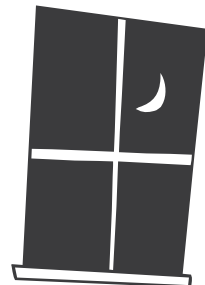

night

Write some n words on another sheet  
or find some n pictures in magazines or newspapers.



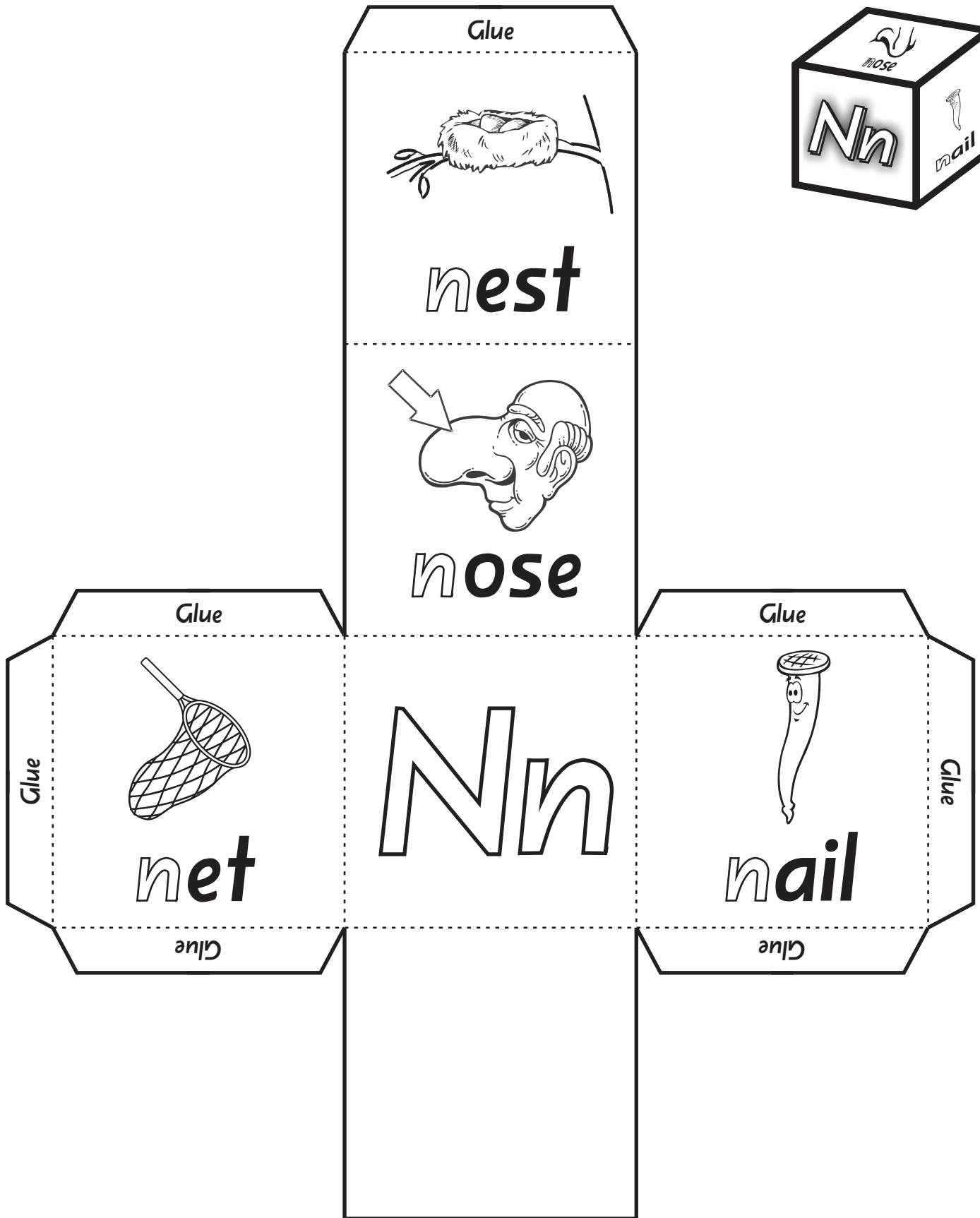
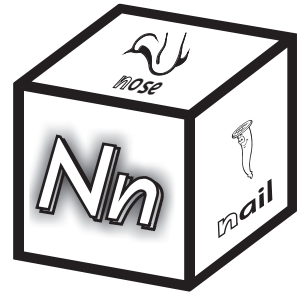

Colour in the big **Nn** sounds.



Colour the **n** pictures.



Trace over the **n** sounds in the words.



Draw your own **n** picture in the blank square.

Cut along the straight lines and fold along the dotted lines. Glue it together to make a cube.



Trace any n sounds. Colour any picture that starts with n.



n

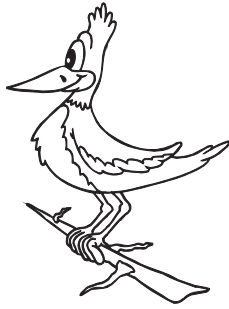

n

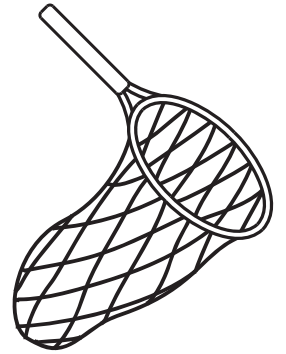

n

n

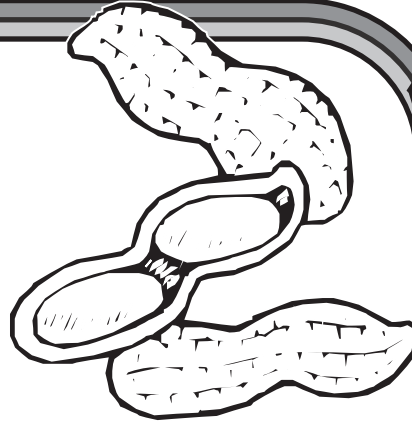

nuts

n

Draw your own n picture.

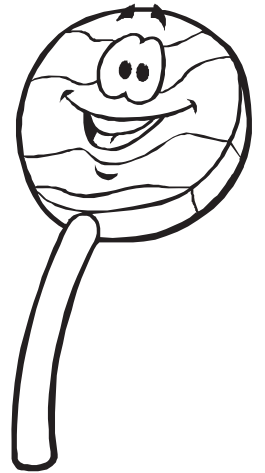
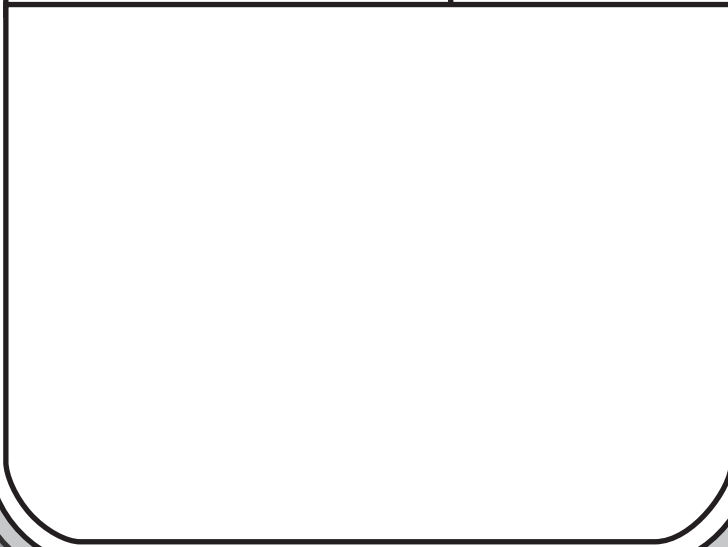

n

n



r

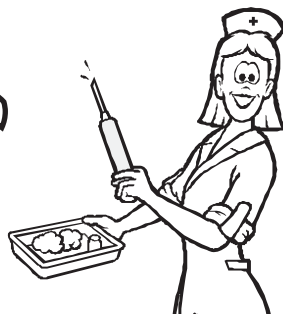

n

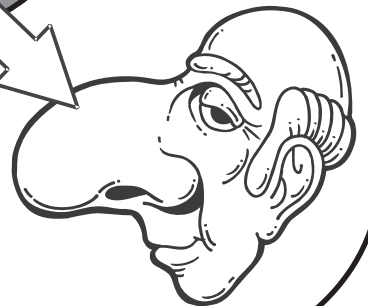

n N

Draw a line to match the picture and word. Write the sound.



est



od



uts



et

un

Circle the words that start with n.

mat    nod    not    met    no  
nip    map    nap    numbers  
nail    sale    next    navy

There are  n words.

Colour the pictures that start with n.

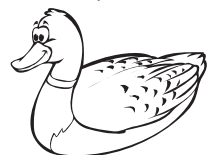
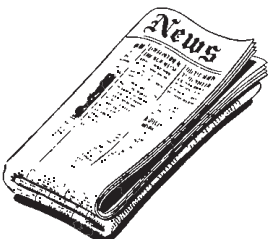
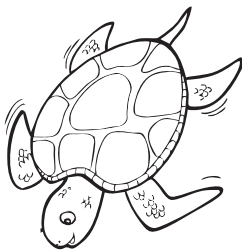
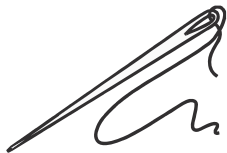

nn



- 1** Paint the nest and branch. Colour and cut out eggs that have *n* words written on them. Paste these in the nest and shade the background blue.
- 2** Use paper chipping and/or rolling to decorate the nest. Colour and cut out a bird or baby birds to place in the nest.
- 3** Write *n* words onto pieces of paper. Cut a slit on the inside of the nest. Poke the words through so that they are half sticking out.

Trace the **o** sounds.

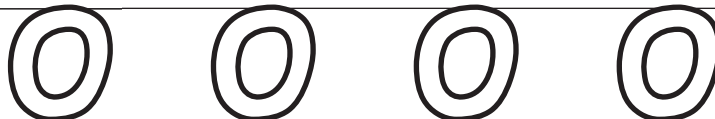
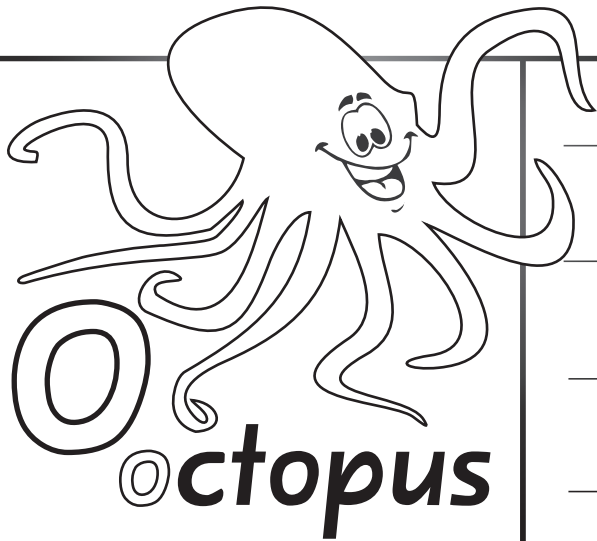

Colour the pictures that start with **o**.

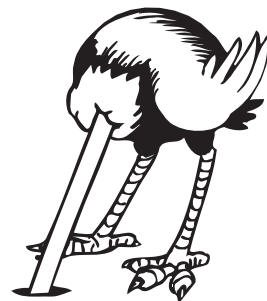
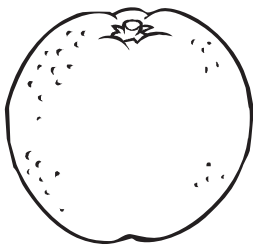
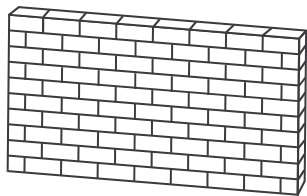

Trace the octopus and colour the picture.  
Read the sentence and trace the **o** sounds.

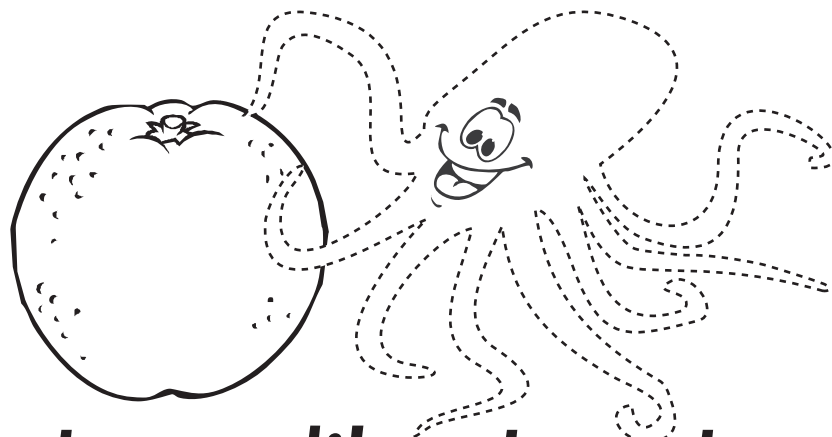

**The **o**ctopus likes to eat **o**ranges.**

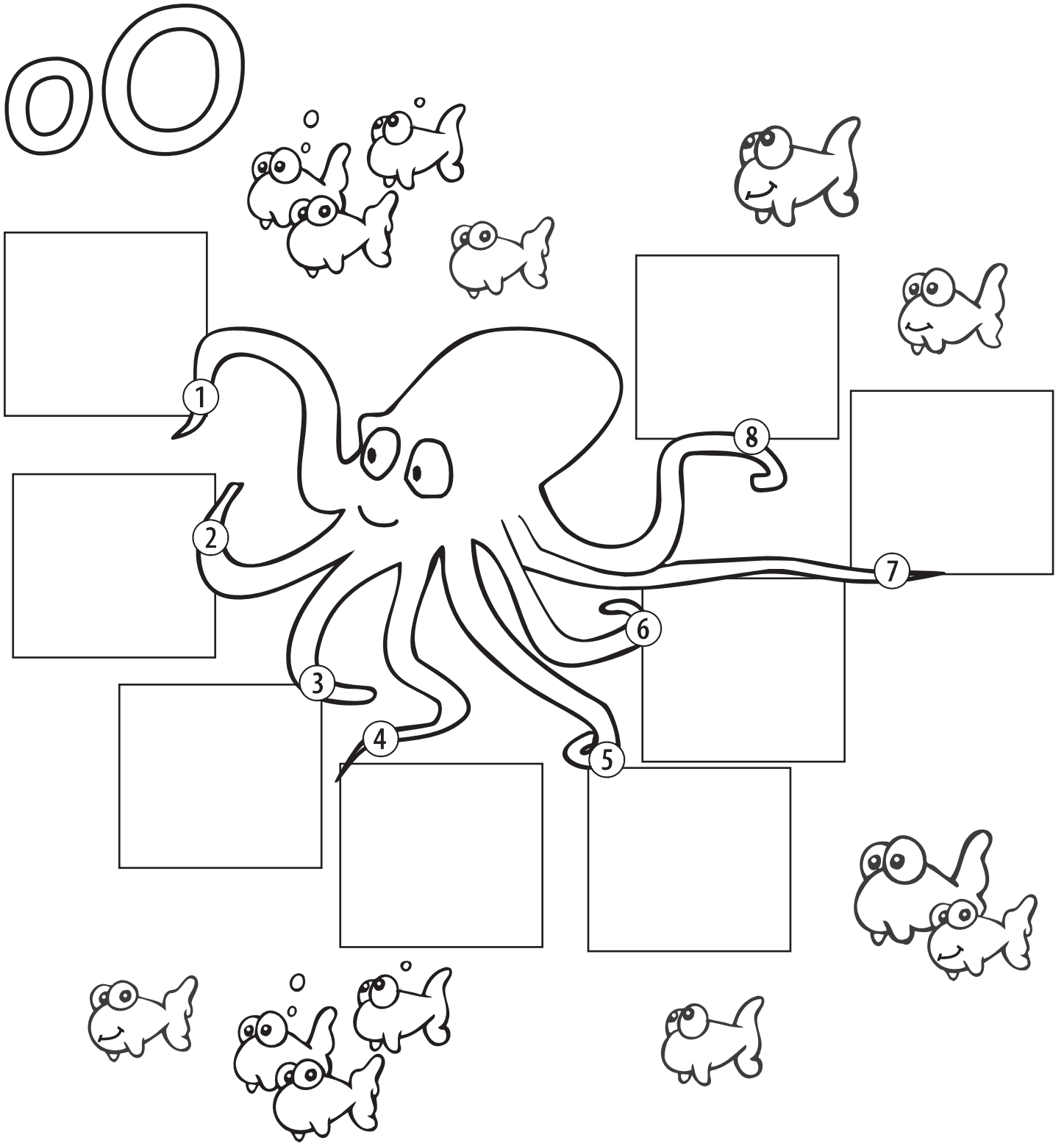

**Olly octopus has lots of o pictures.**

- ☺ Colour the octopus and draw (or cut out pictures from magazines) an o picture on the end of each tentacle e.g. orange, ostrich, oblong otter, ox etc.
- ☺ Trace over the o words in the sentence.

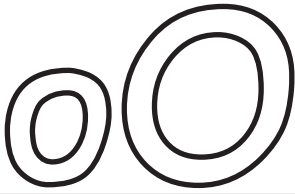

1. Colour the pictures that start with o.
2. Trace the o words.

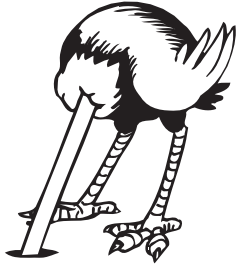

ostrich

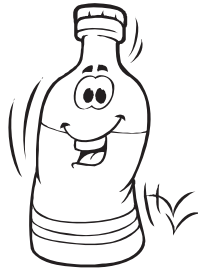

bottle

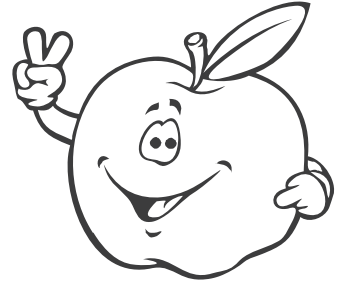

apple

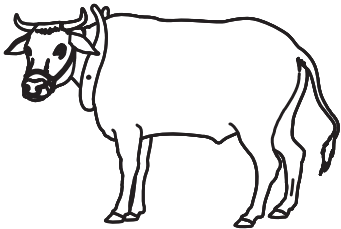

ox

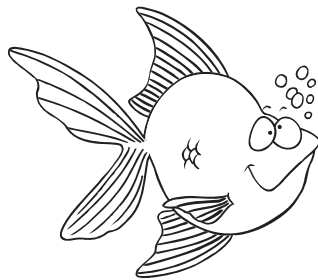

fish

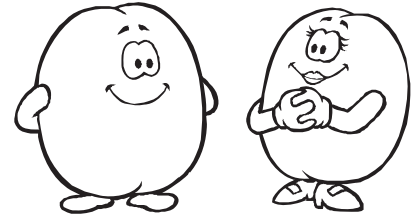

olives



off

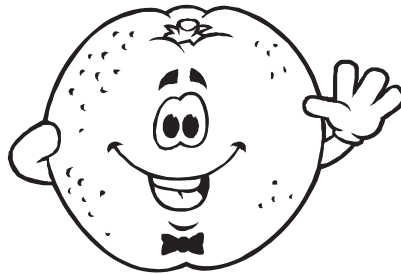

orange



October

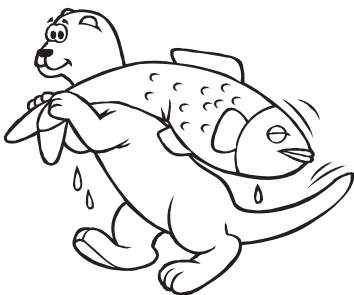

otter

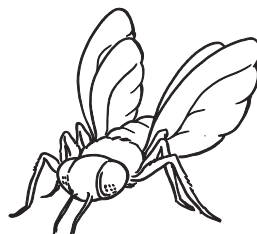

fly

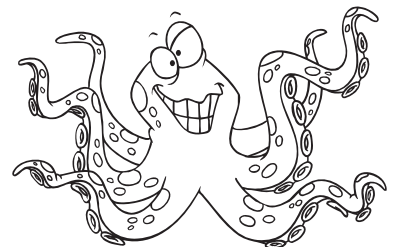

octopus

Write some o words on another sheet  
or find some o pictures in magazines or newspapers.



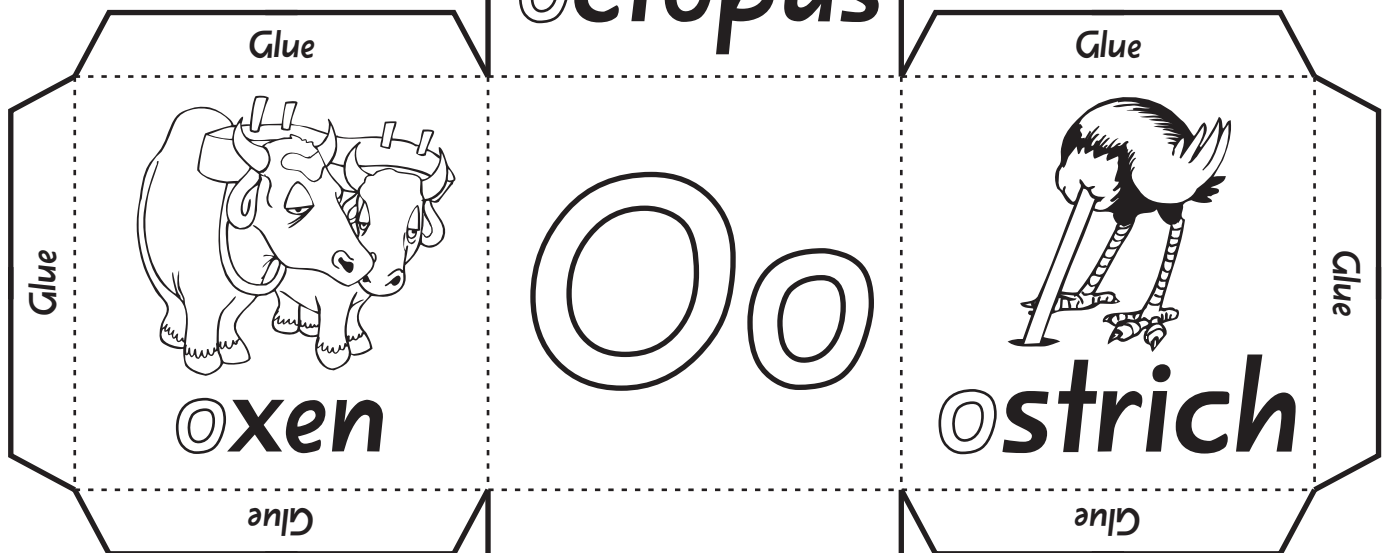
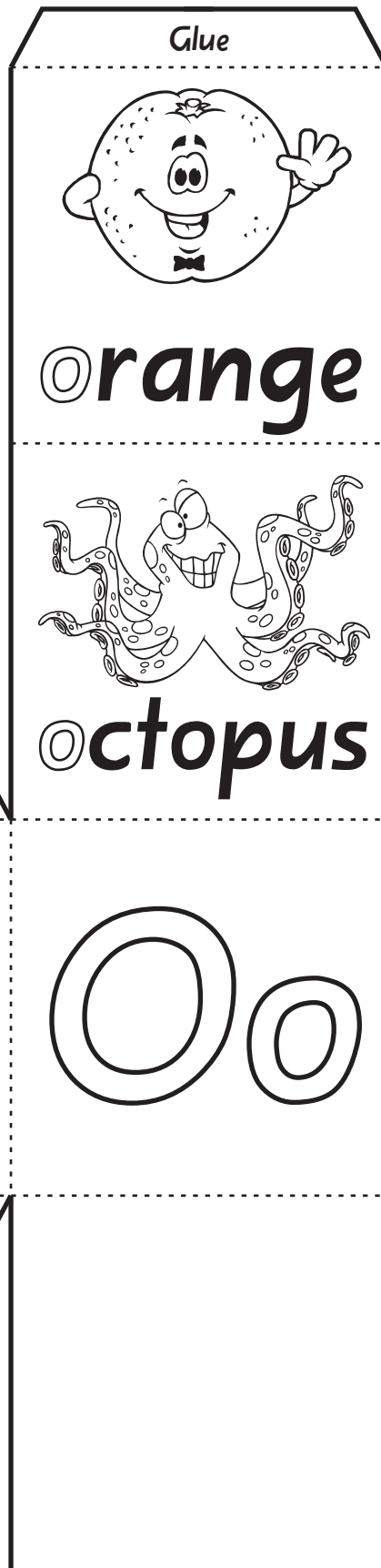
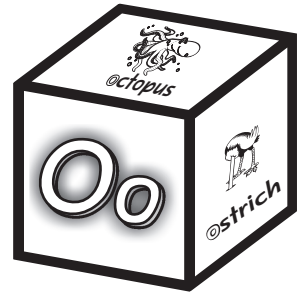

Colour in the big **O** sounds.



Colour the **O** pictures.



Trace over the **O** sounds in the words.



Draw your own **O** picture in the blank square.

Cut along the straight lines and fold along the dotted lines. Glue it together to make a cube.



Trace any **o** sounds. Colour any picture that starts with **o**.

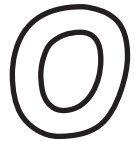
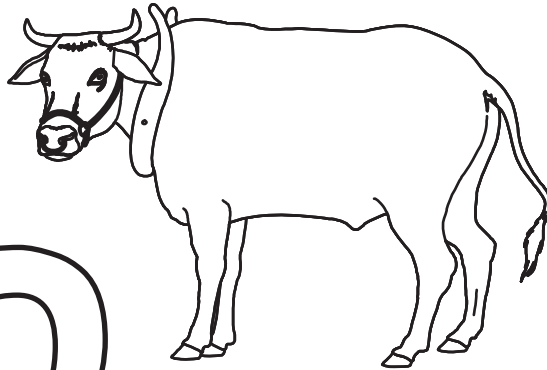
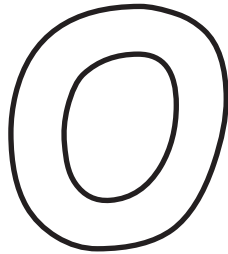
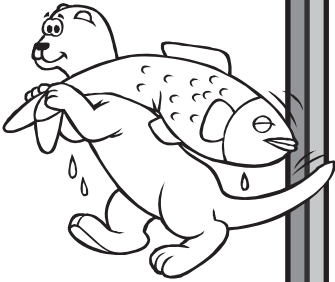
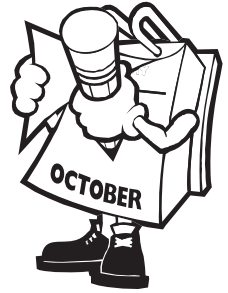
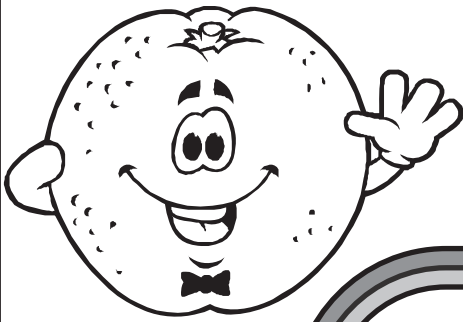

Draw your own **o** picture.

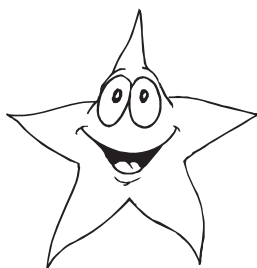
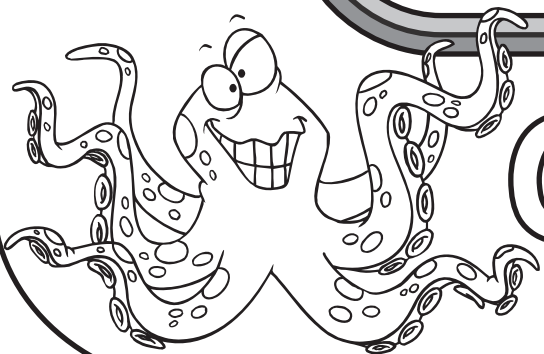
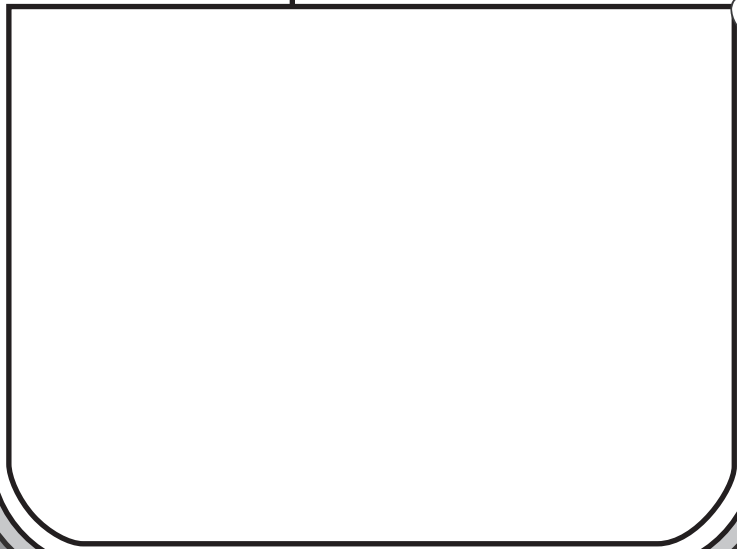

Draw a line to match the picture and word. Write the sound.

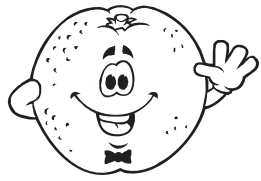

strich

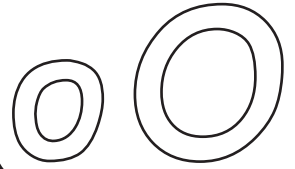

n

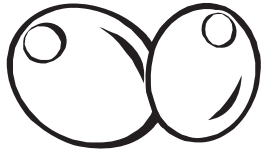

ff



lives



range

Circle the words that start with o.

ox    odd    orange    operation

all    octopus    olives    rusty

oblong    car    off    onto    on

There are  o words.

Colour the pictures that start with o.

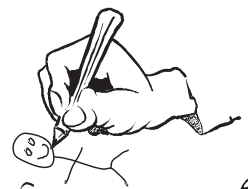

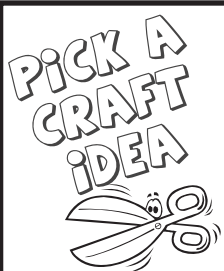
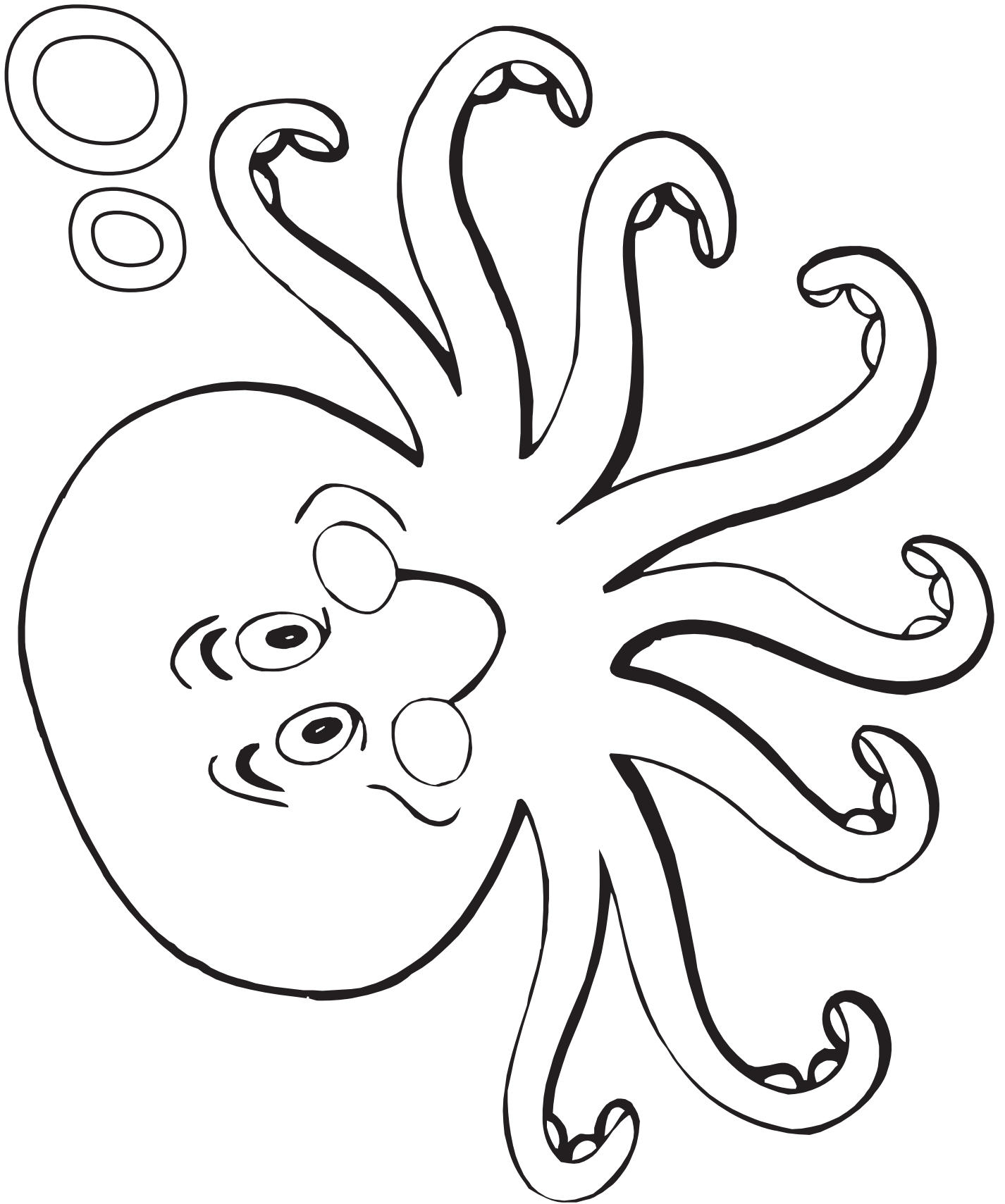

- 1** Colour in the octopus and write © words on the tentacles. Decorate the rest of the animal with © patterns.
- 2** Colour the octopus with crayon and draw seaweed, rocks, fish etc around it in crayons also. Cover the lot with a blue wash.
- 3** Colour the octopus and cut some slits between and around the tentacles. Write © words on paper and place into these slits, strangling the words.

Trace the **p** sounds.

**P**

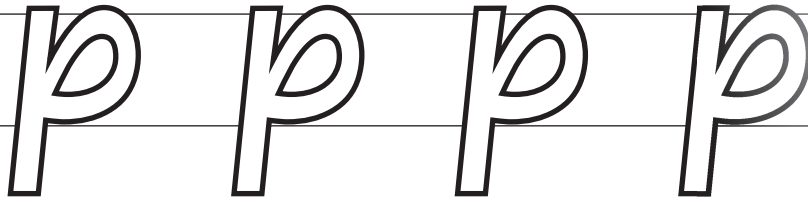
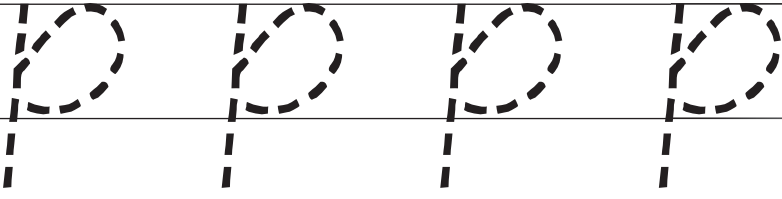

**p**ot

Colour the pictures that start with **p**.

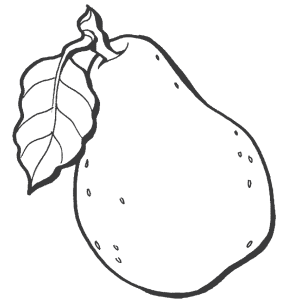
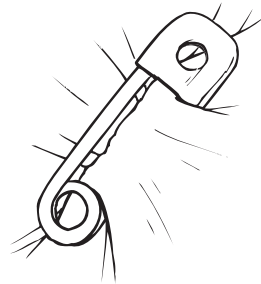
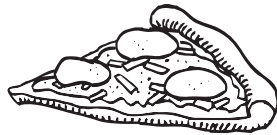
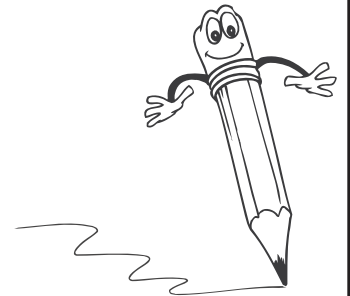
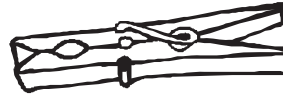
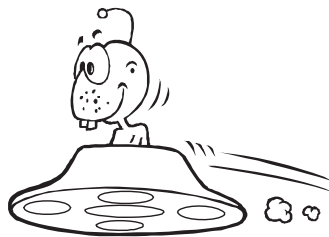

Trace the pigs and colour them pink and purple.  
Read the sentence and trace the **p** sounds.

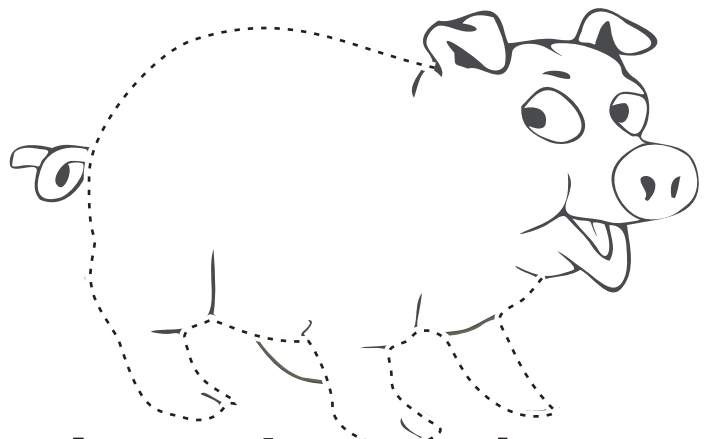
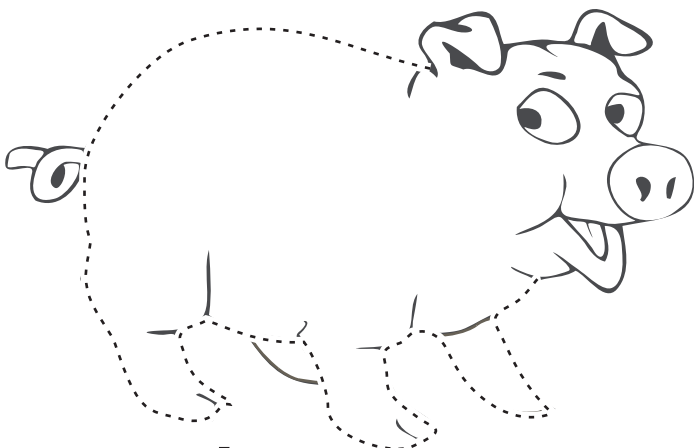

The **p**igs are **p**ink and **p**urple.

p P

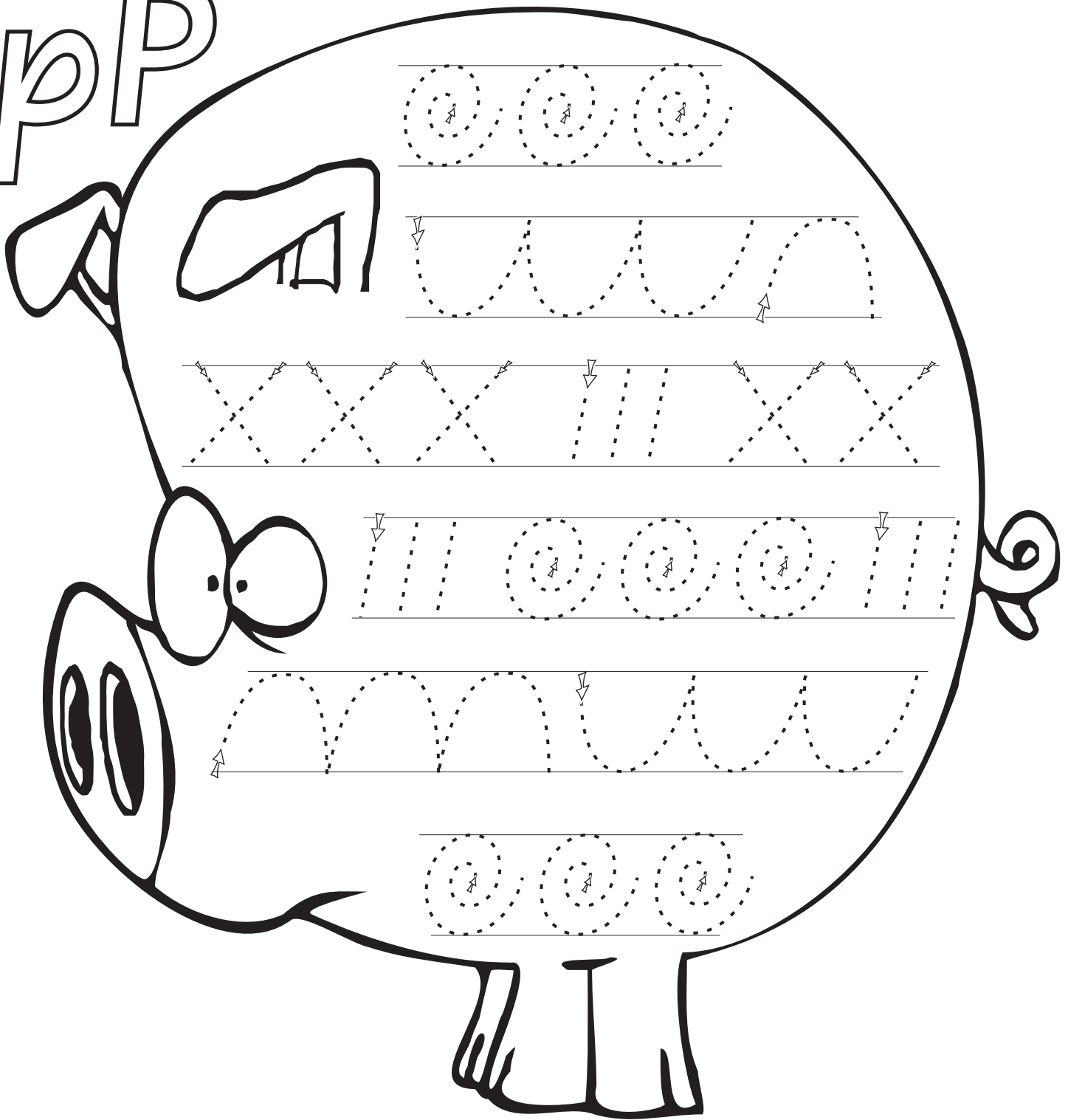

**My pink pig has lots of patterns.**

- ☺ Trace over the writing patterns in different colours.
- ☺ Colour the pig pink.
- ☺ Trace over the p sounds in the sentence.

pP

1. Colour the pictures that start with p.
2. Trace the p words.



pie

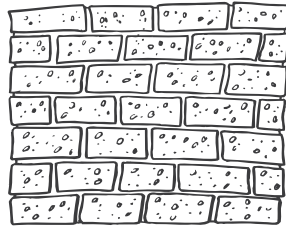

wall

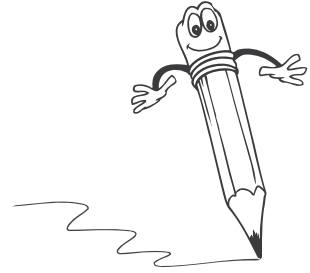

pencil

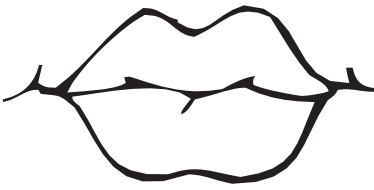

lips

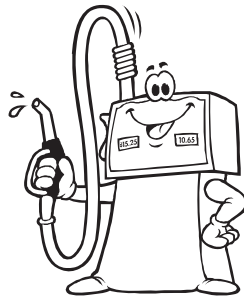

petrol



popcorn



pot

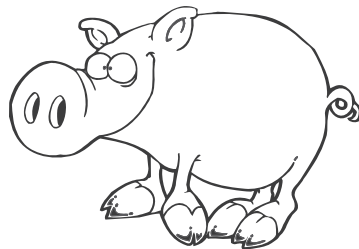

pig

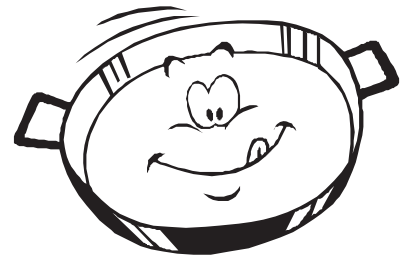

pan



peas

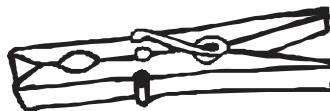

peg



paint

Write some p words on another sheet  
or find some p pictures in magazines or newspapers.

EXTRA  
STUFF



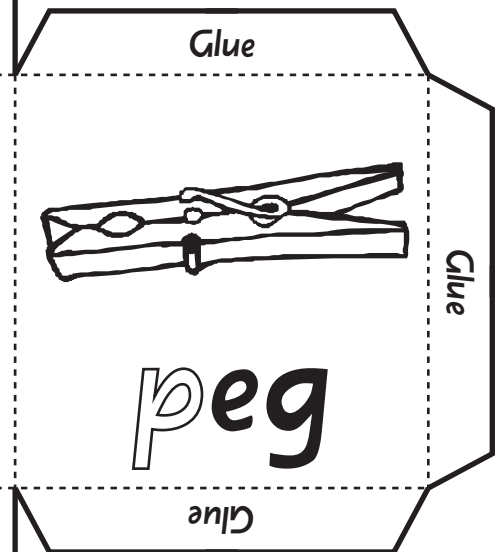
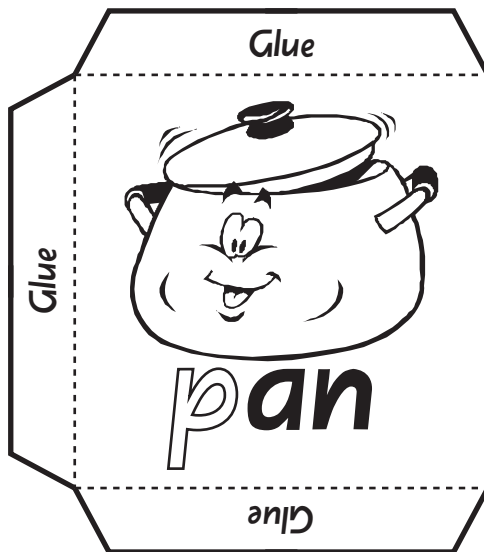
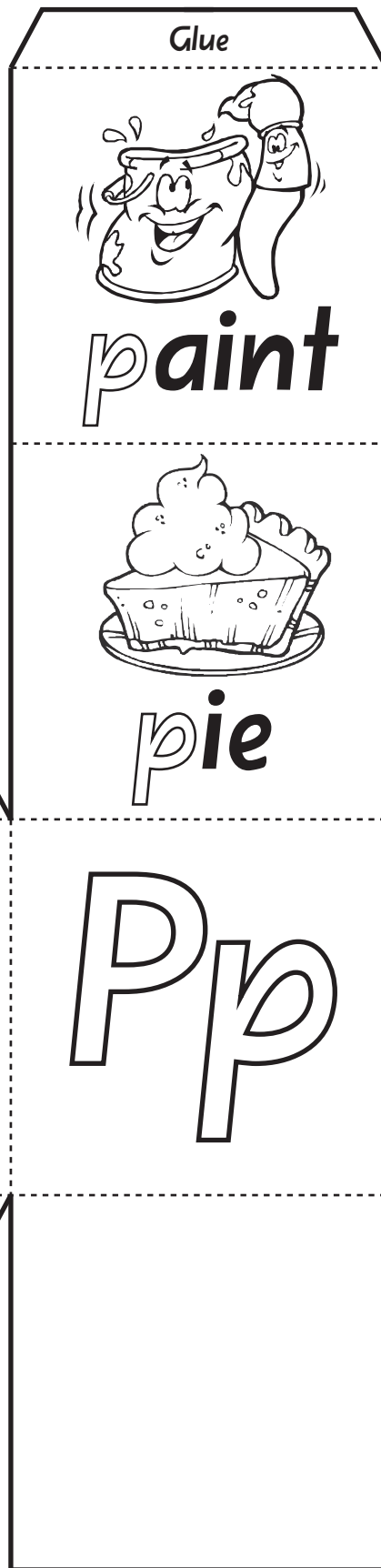
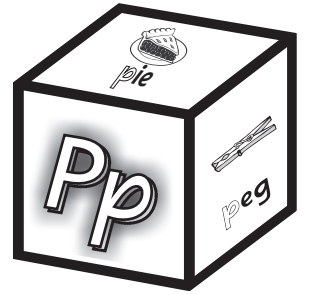

- 😊 Colour in the big Pp sounds.
- 😊 Colour the p pictures.
- 😊 Trace over the p sounds in the words.
- 😊 Draw your own p picture in the blank square.

Cut along the straight lines and fold along the dotted lines. Glue it together to make a cube.



Trace any p sounds. Colour any picture that starts with p.



p

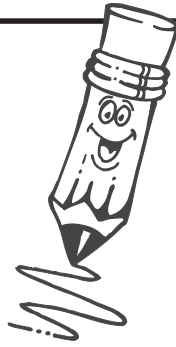

p

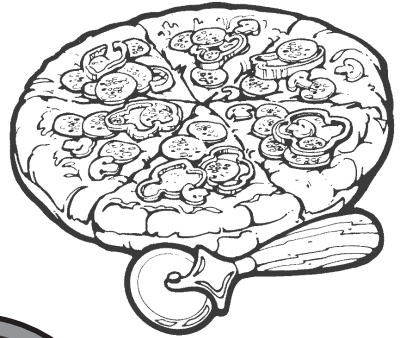

p

p

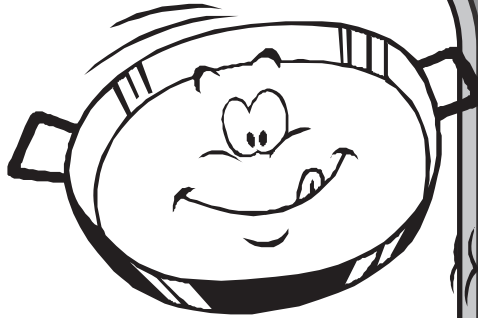

pan



p



p

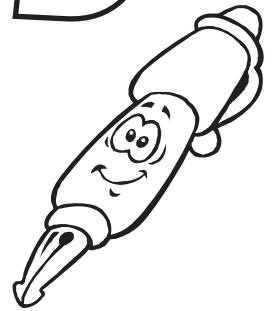

Draw your own p picture.

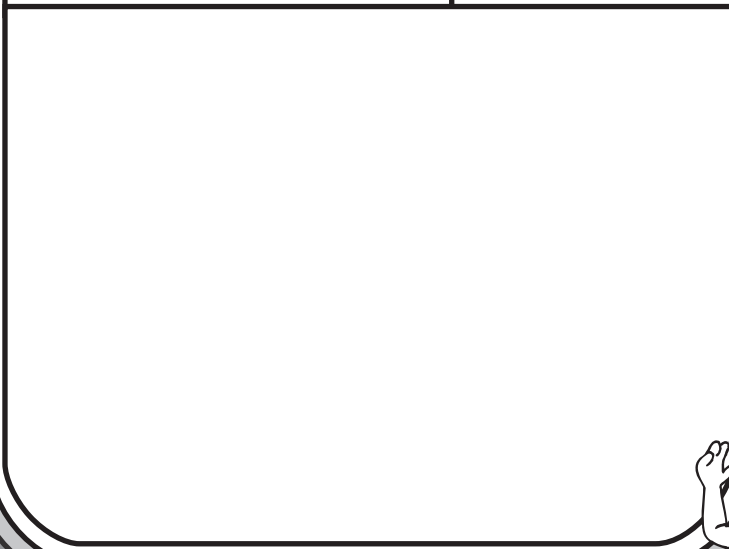

p

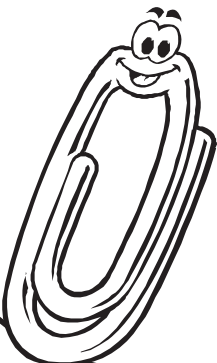

p

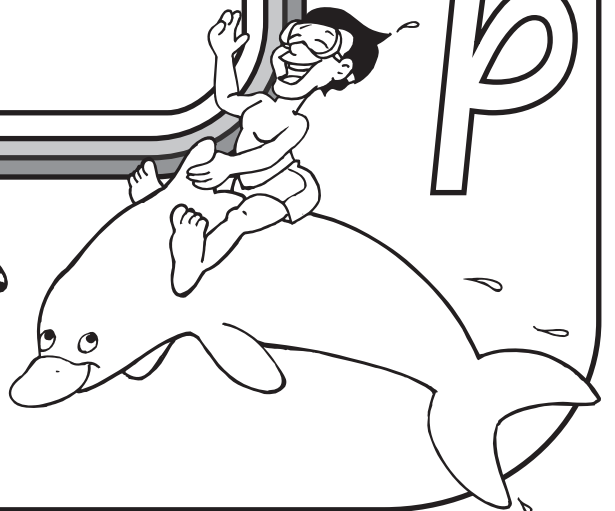
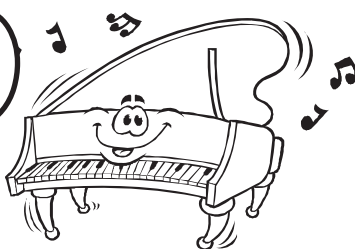

p P

Draw a line to match the picture and word. Write the sound.

in

eg

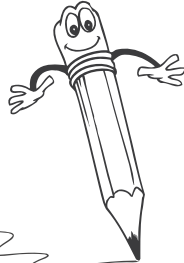
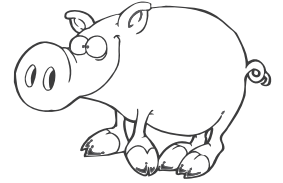

ig

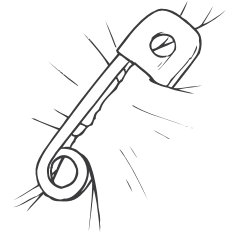

an

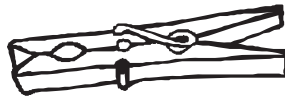

encil

Circle the words that start with p.

paint

pen

jog

pizza

got

put

purr

yet

pot

pig

pop

tow

paper

pit

There are  p words.

Colour the pictures that start with p.

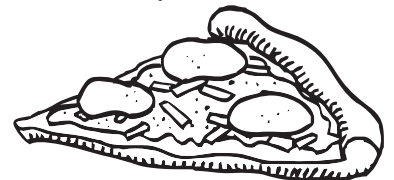
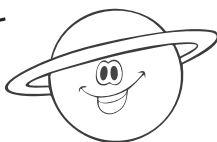
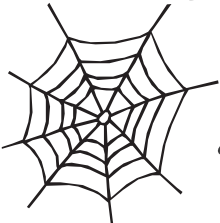
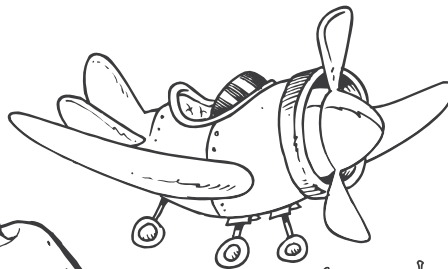
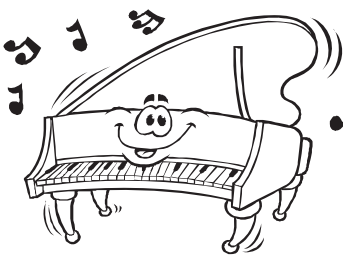

p P

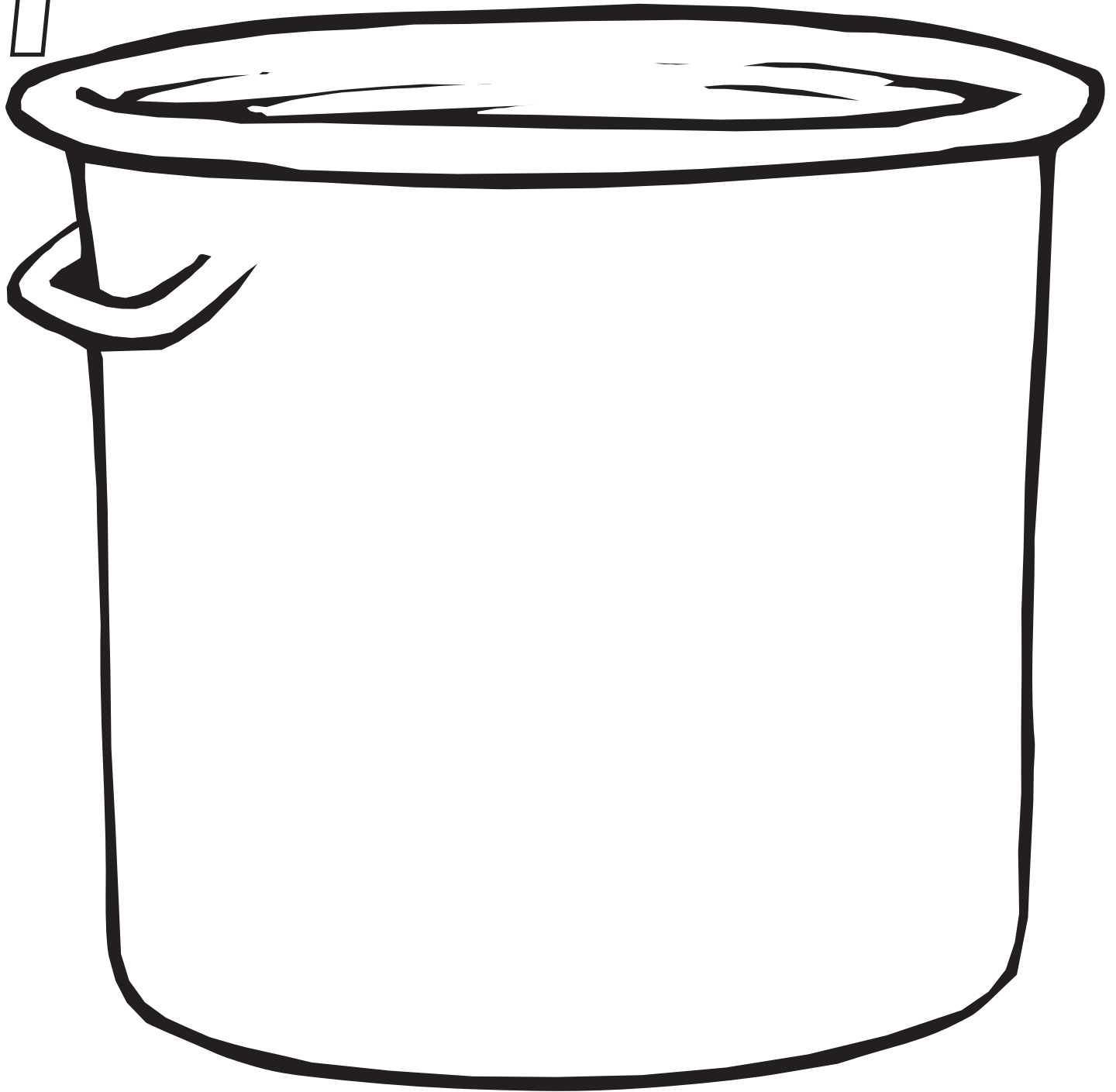

PICK A  
CRAFT  
IDEA



- 1** Colour or paint the pot. Draw pieces of popcorn around the pot. Write *p* words inside them.
- 2** Decorate the pot with the letter *p*. Draw or cut out from magazines things that start with *p* and paste them around the pot.
- 3** Draw one big *p* picture on the pot. Surround the pot with a pink and purple scribble pattern.

Trace the q sounds.



queen

q

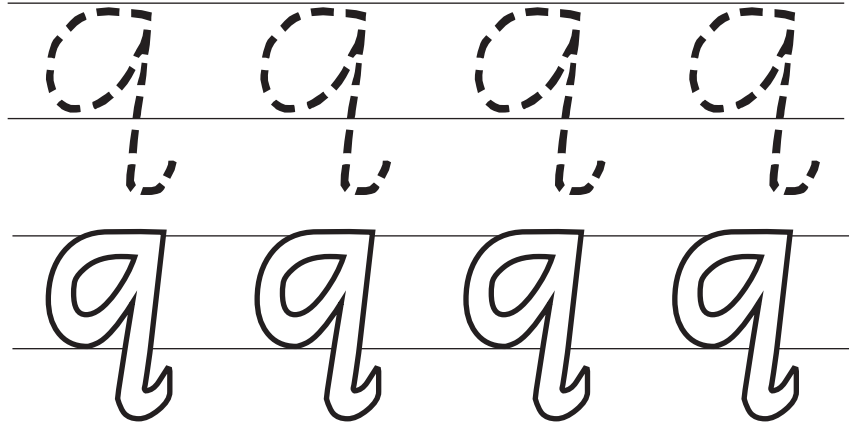

Colour the pictures that start with q.

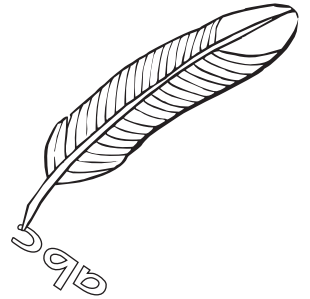
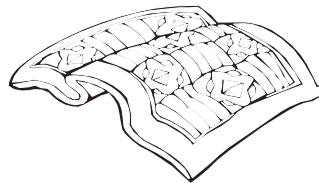
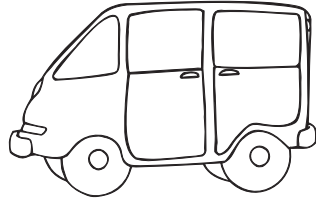

Colour the matching patterns in the quilt the same colours.  
Read the sentence and trace the q sounds.

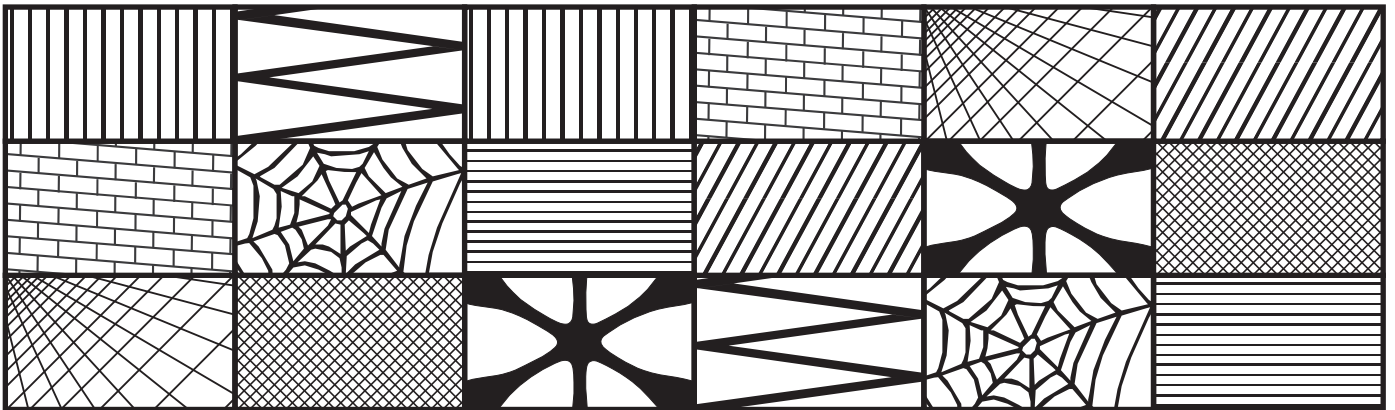

The queen has a colourful quilt.

q Q

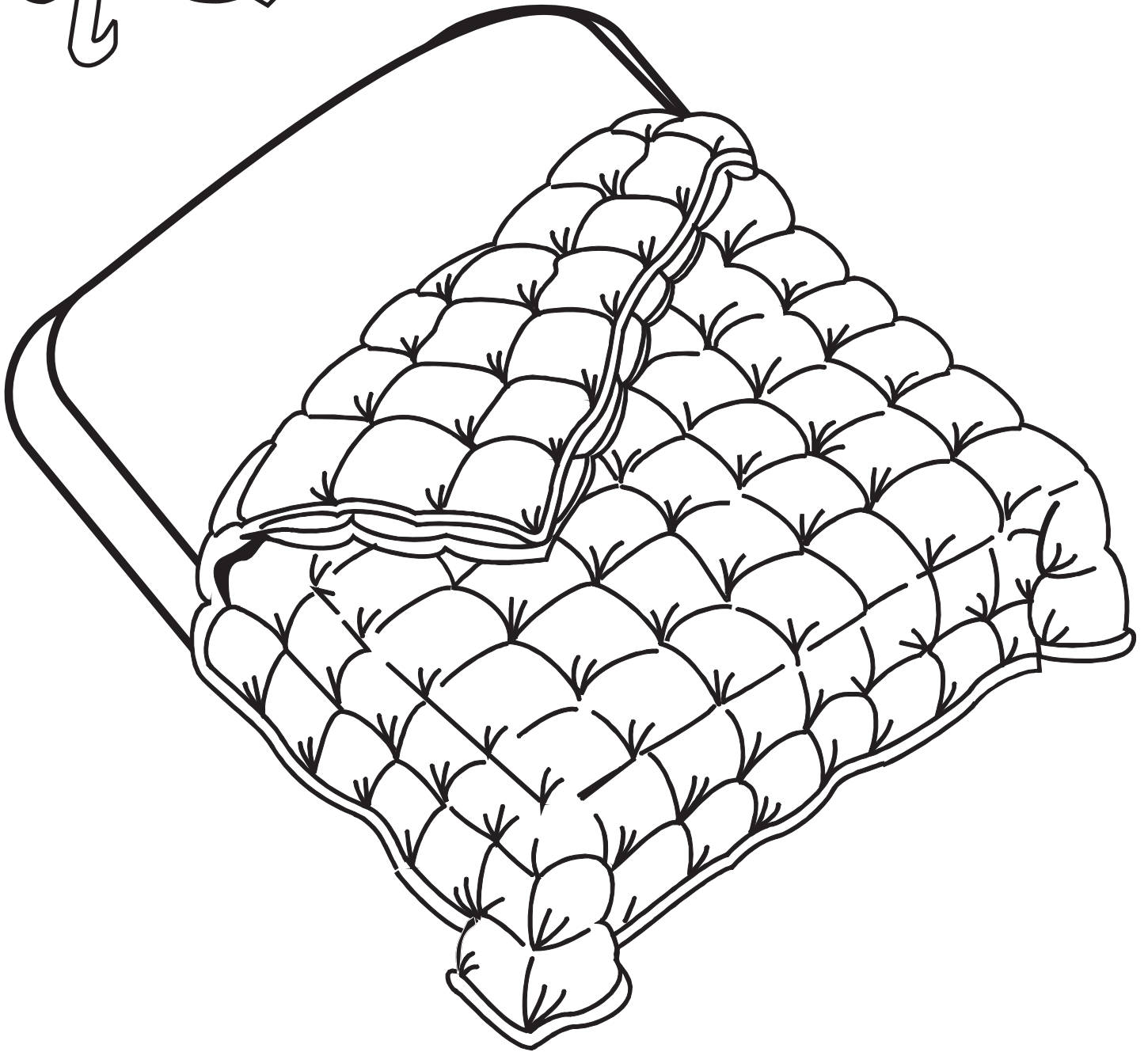

*The **q**uads are under the **q**uilt.*



*Draw 4 baby heads at the top of the quilt.*



*Colour the squares of the quilt or fill them with patterns.*



*Trace over the **q** words in the sentence.*

# q Q

1. Colour the pictures that start with q.
2. Trace the q words.

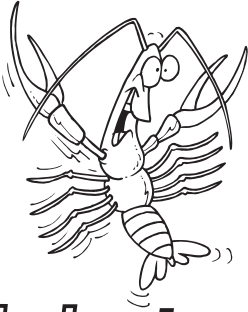

lobster

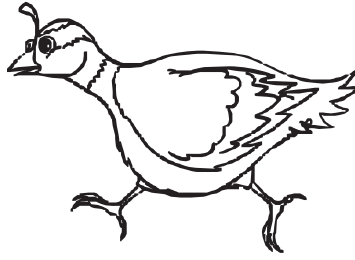

quail



queen

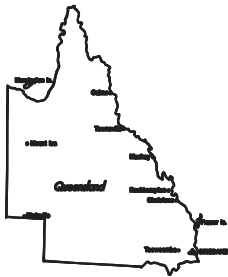

Queensland

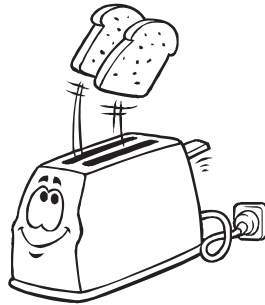

toaster



question



painting



quill



peas

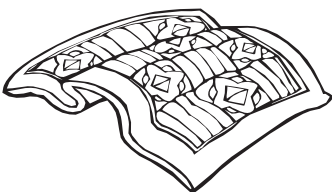

quilt

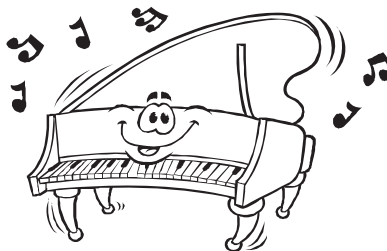

piano

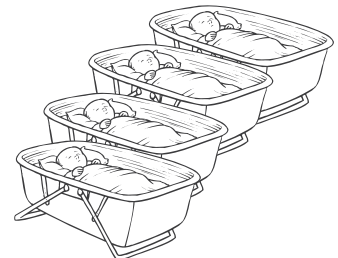

quads

Write some q words on another sheet  
or find some q pictures in magazines or newspapers.



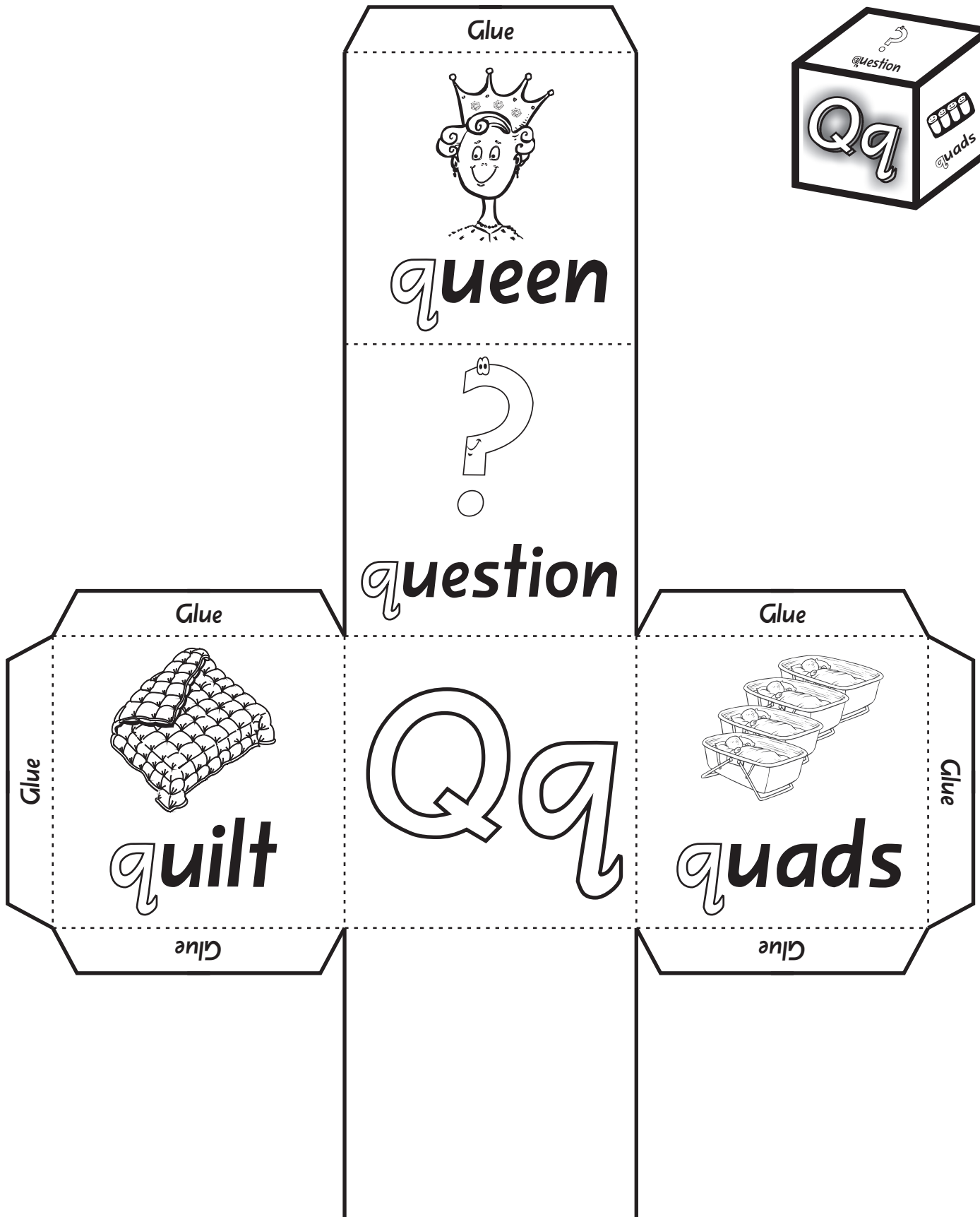

Colour in the big Qq sounds.



Colour the q pictures.



Trace over the q sounds in the words.



Draw your own q picture in the blank square.

Cut along the straight lines and fold along the dotted lines. Glue it together to make a cube.



Trace any *q* sounds. Colour any picture that starts with *q*.



q



q

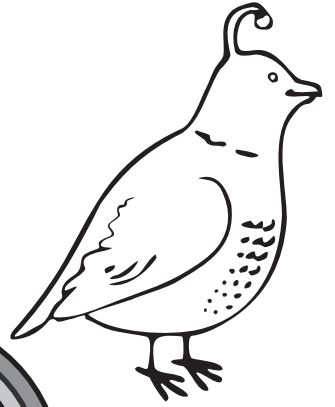

q



q

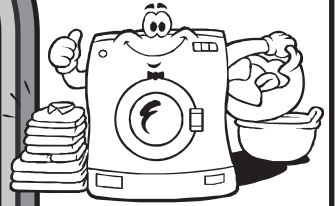

quilt

Draw your own *q* picture.

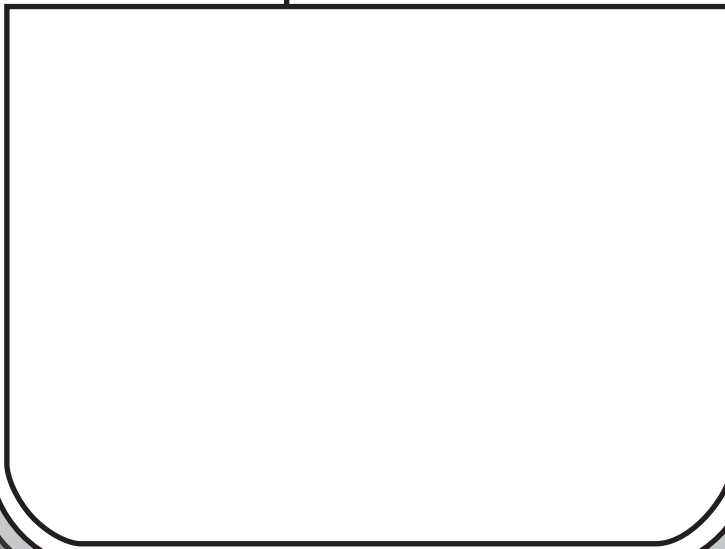

q

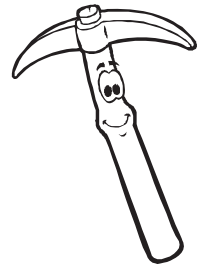

q

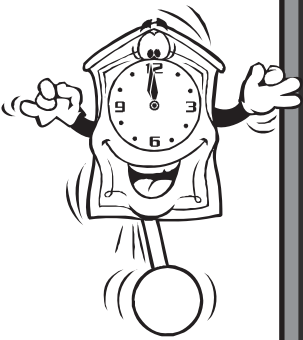

q



q



q



Draw a line to match the picture and word. Write the sound.

q Q

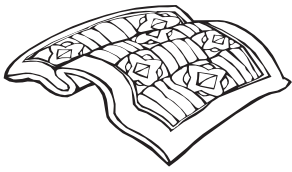

uail



ueen

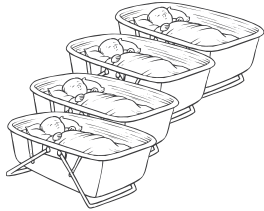

uilt

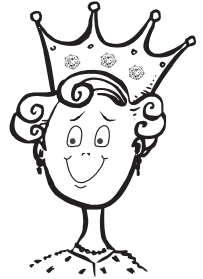

uads

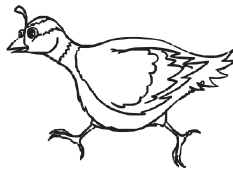

uestion

Circle the words that start with q.

quick

queen

queer

quiet

pill

gate

quite

quill

quit

queue

bake

quiver

There are  q words.

Colour the pictures that start with q.

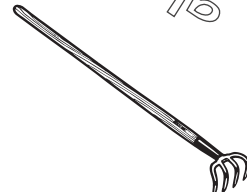
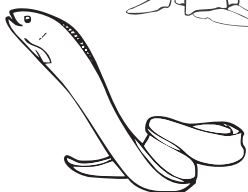
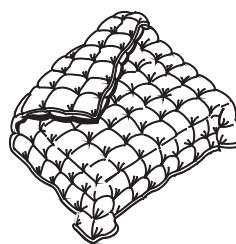
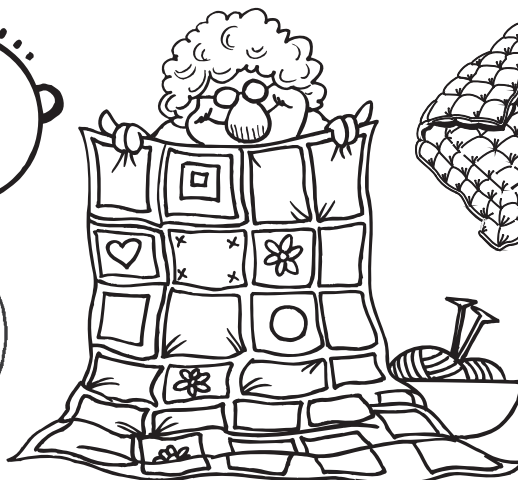
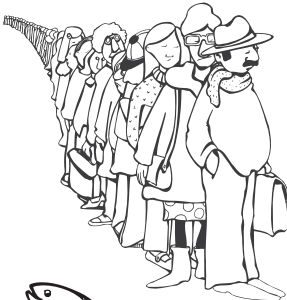



pick a  
craft  
idea



- 1** Colour the queen and surround her with as many *q* words as possible. Then add some colour.
- 2** Make a crown to wear home from a simple band of paper stapled into a ring. Write *q* words all around it and add colour.
- 3** Make a paper chain with *q* words written on each link. These can be made into a queen's necklace or used to decorate the room.

Trace the r sounds.

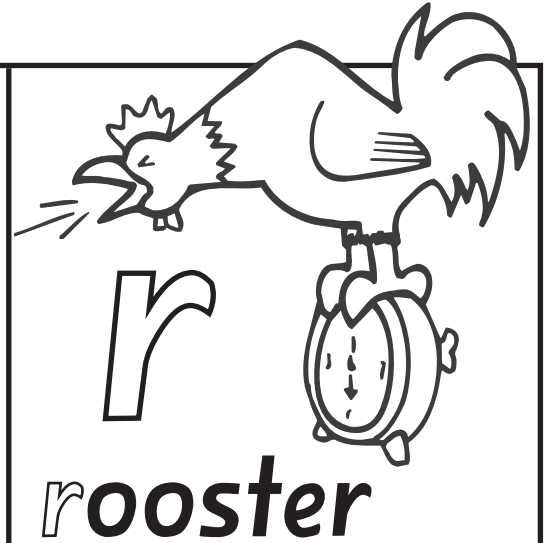
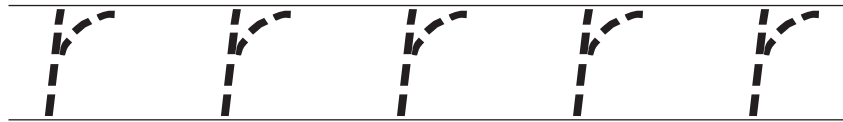

Colour the pictures that start with r

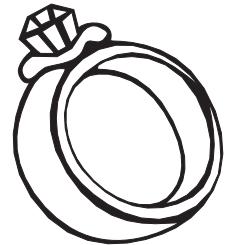
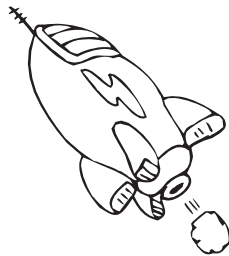
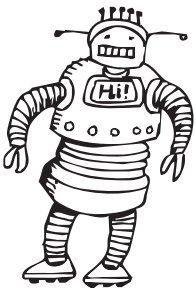
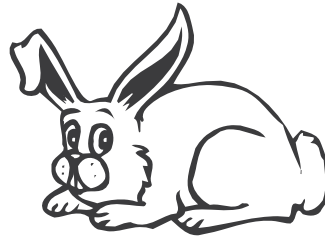
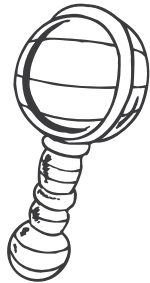
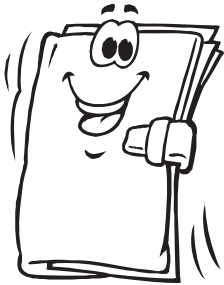

Trace the rainbow and colour the picture.  
Read the sentence and trace the r sounds.

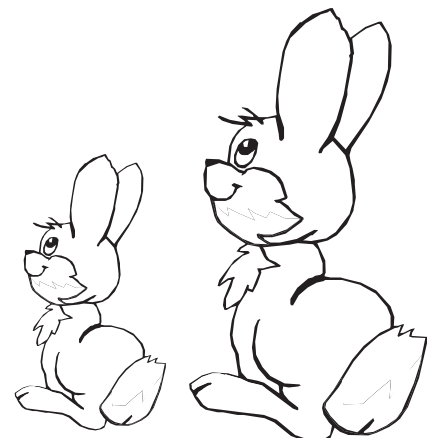
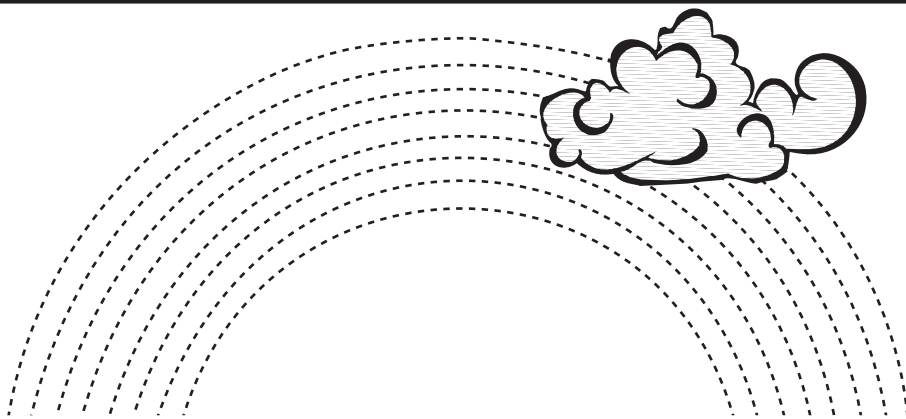

The r rabbits are near the r ainbow.

rR

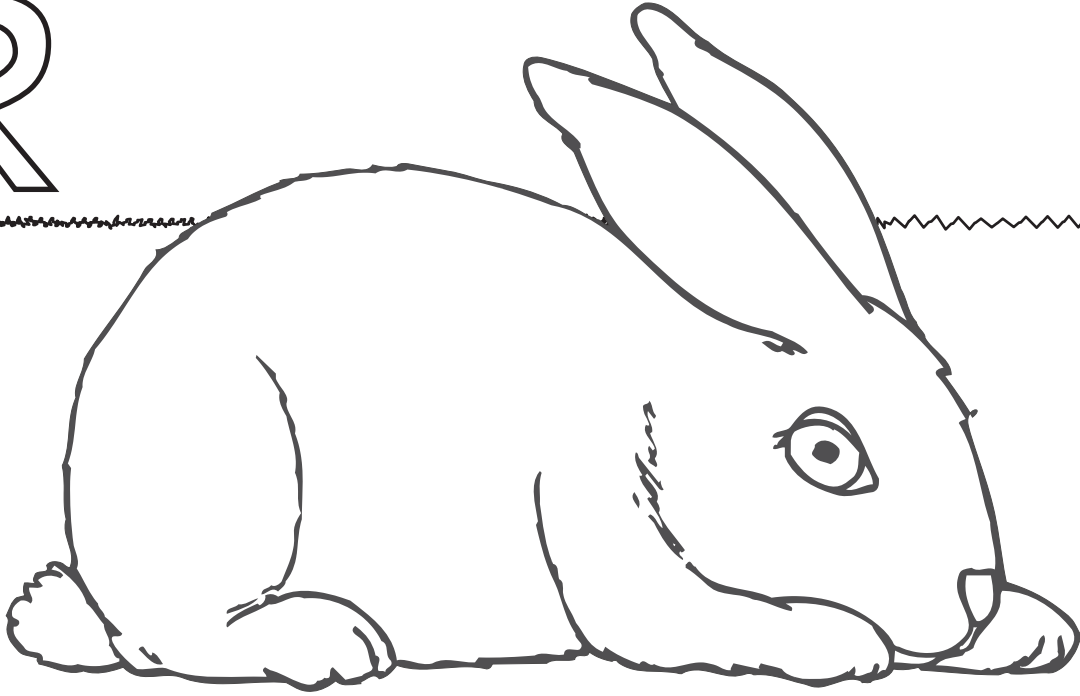

**The *r*abbit *r*ests on the *r*ug.**

- ☺ Colour the rabbit.
- ☺ Write the *r* sound all over the rug.
- ☺ Trace over the *r* sounds in the sentence.

# rR

1. Colour the pictures that start with *r*.
2. Trace the *r* words.

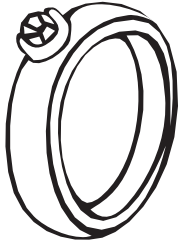

ring



rabbit

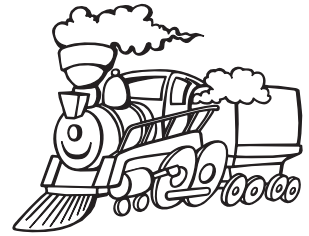

train

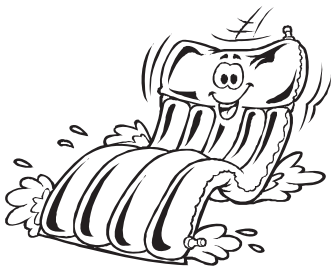

raft

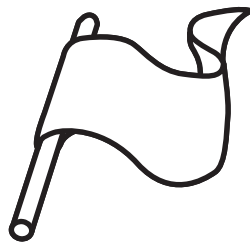

flag



rain

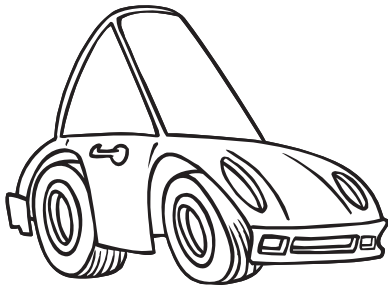

car

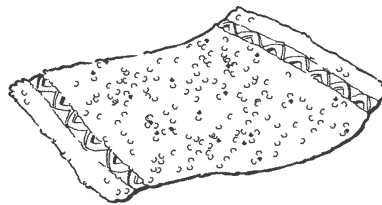

rug



rubber



rattle

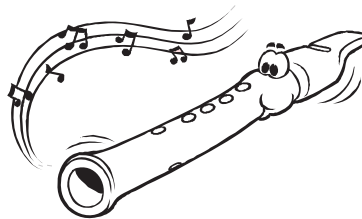

recorder







read

Write some *r* words on another sheet  
or find some *r* pictures in magazines or newspapers.

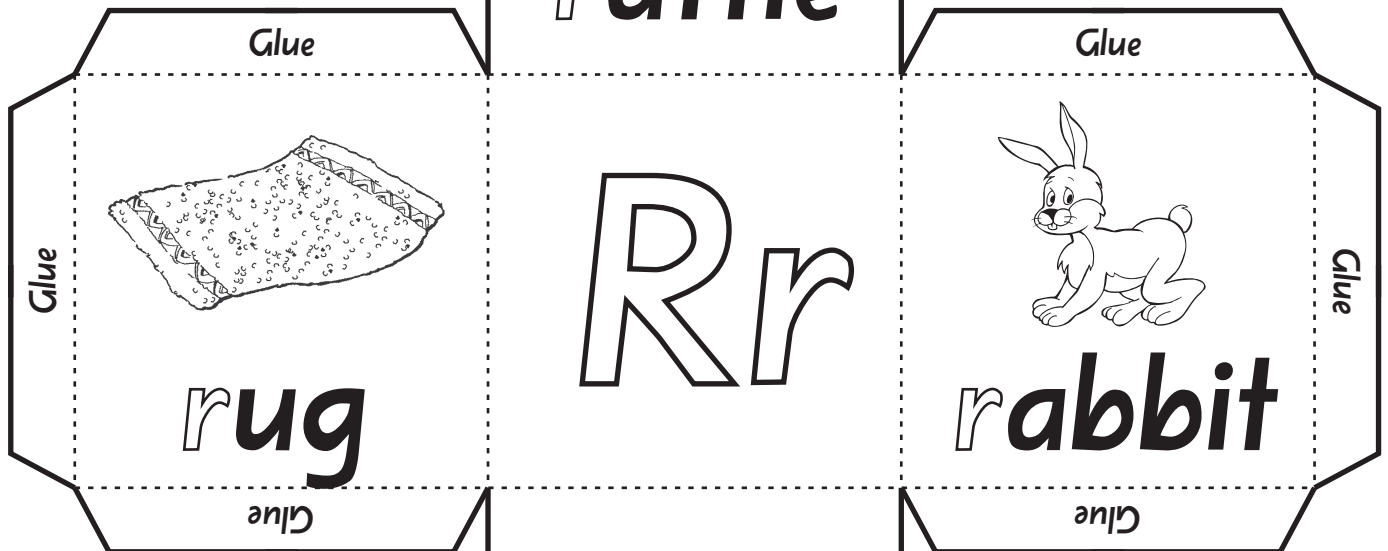
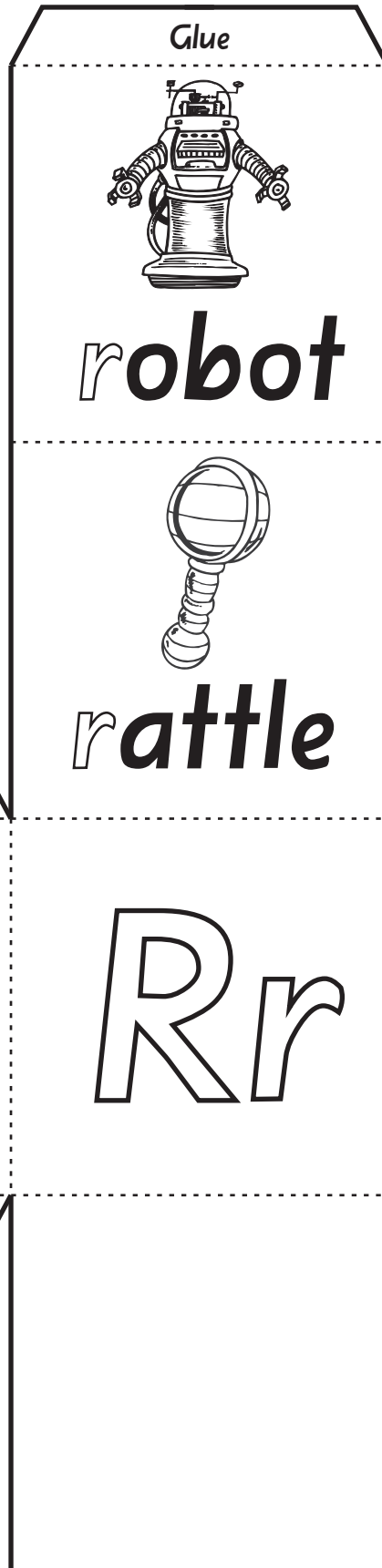
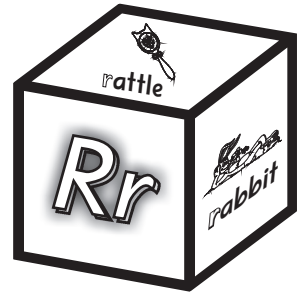
EXTRA  
STUFF





-  Colour in the big **Rr** sounds.
-  Colour the **r** pictures.
-  Trace over the **r** sounds in the words.
-  Draw your own **r** picture in the blank square.

Cut along the straight lines and fold along the dotted lines. Glue it together to make a cube.



Trace any *r* sounds. Colour any picture that starts with *r*.

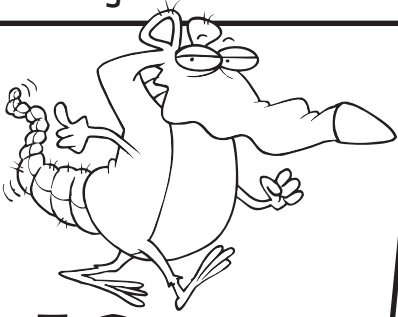

*r*

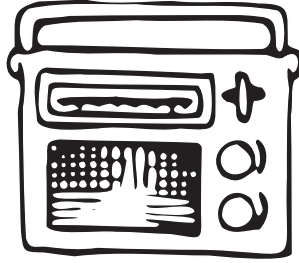

*r*



*n*

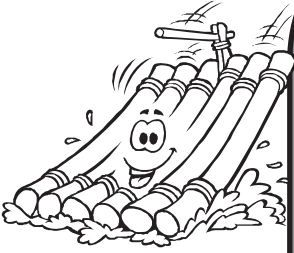

*r*

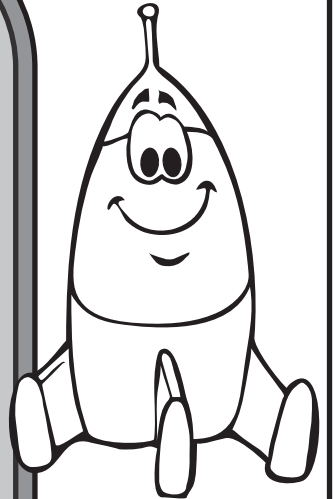

*r*

**ring**

Draw your own *r* picture.

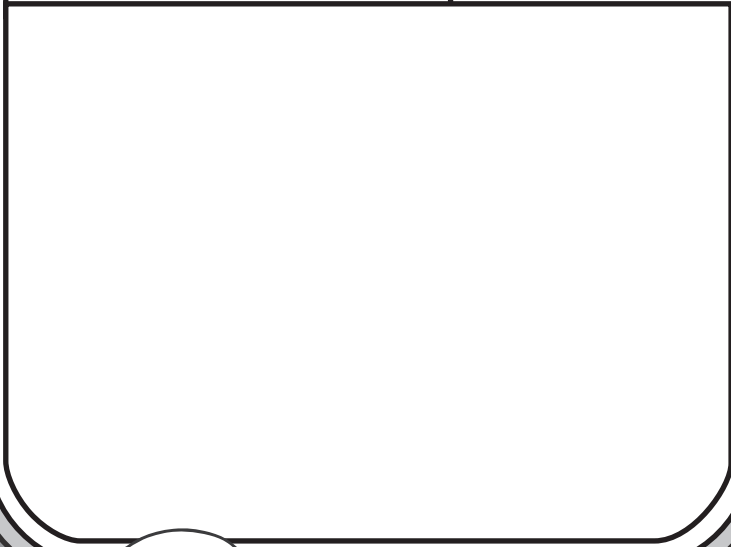

*r*

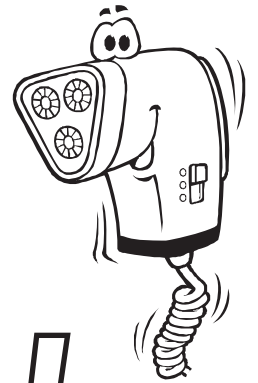

*h*

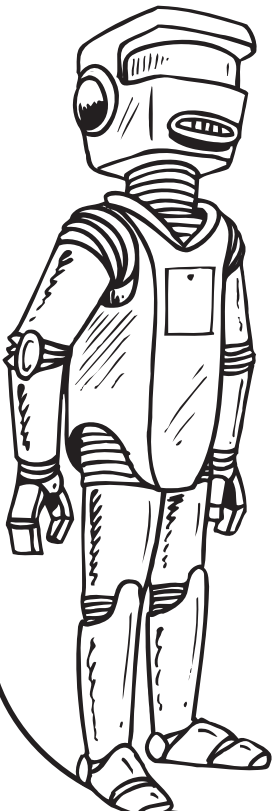

*r*



*r*

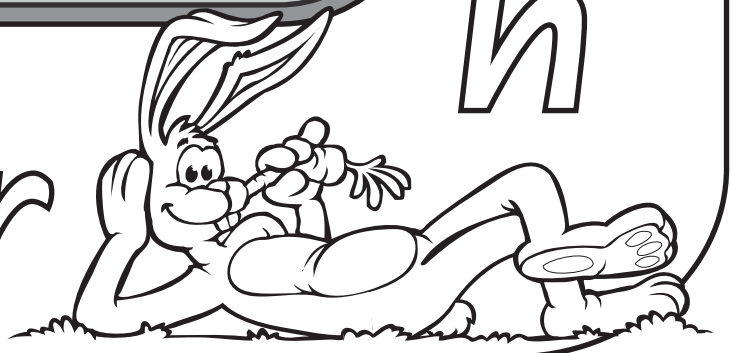

rR

Draw a line to match the picture and word. Write the sound.



obot



un

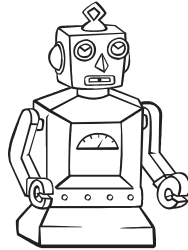

ug

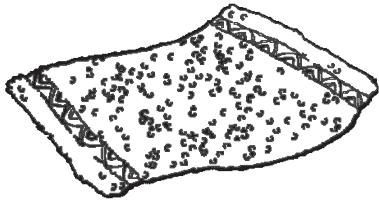

ing

at

Circle the words that start with r.

rabbit    run    set    rub    rib  
sing    relax    sand    rainbow  
risk    rest    task    rang    rot

There are  r words.

Colour the pictures that start with r.

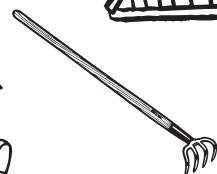
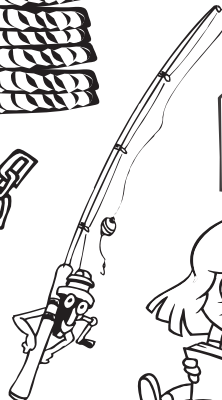
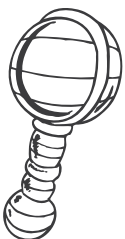
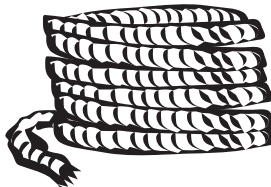

rR

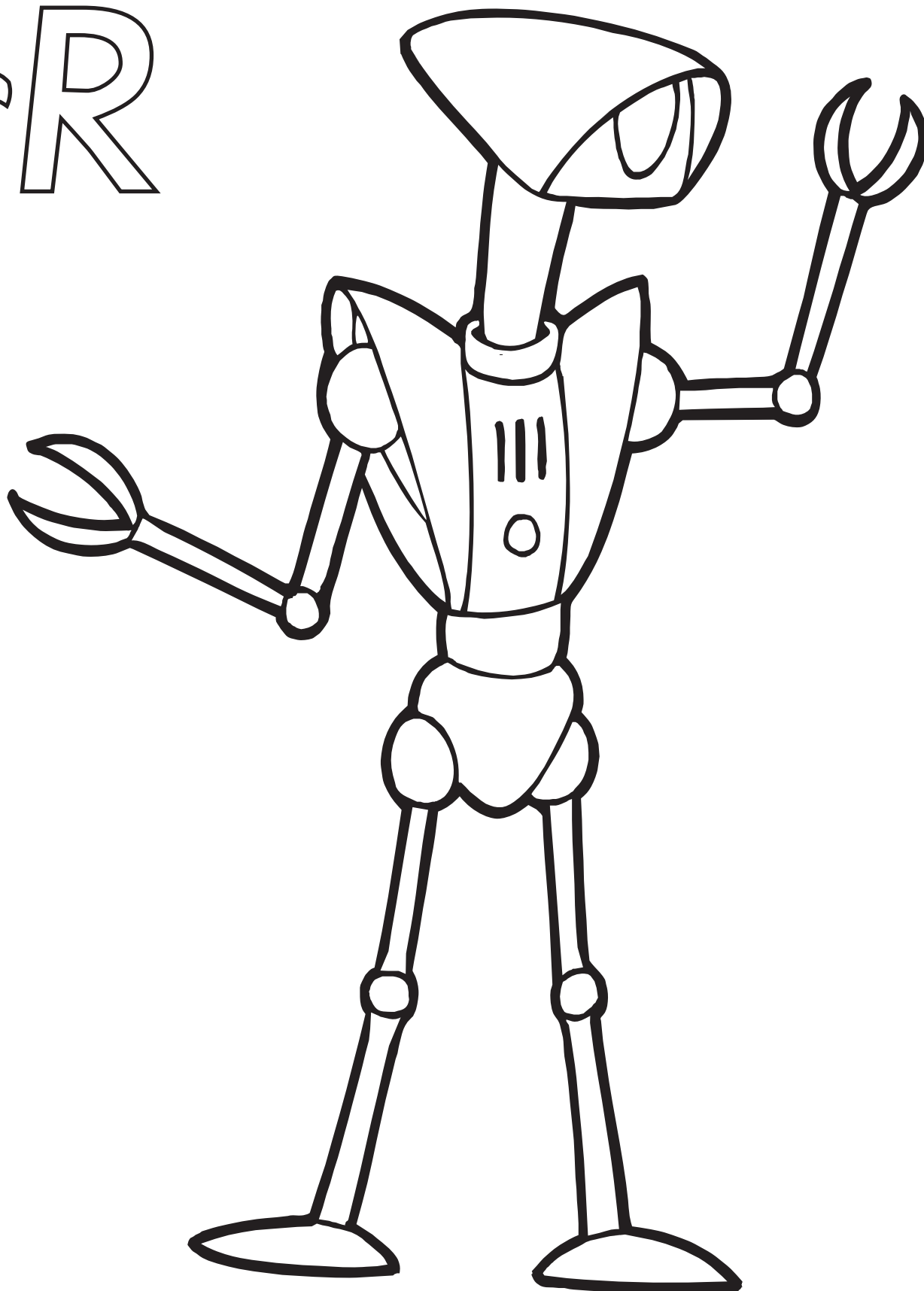

PICK A  
CRAFT  
IDEA



- 1** Colour the robot and draw rain falling in the background with blue crayon, paint over it with a blue wash and put the caption, 'Robots in the rain.'
- 2** Colour the robot and write *r* words on pieces of paper. Paste the words near his left hand as if he were holding them.
- 3** Surround the robot with *r* words or *r* pictures after colouring it in with crayons or paint.

Trace the s sounds.

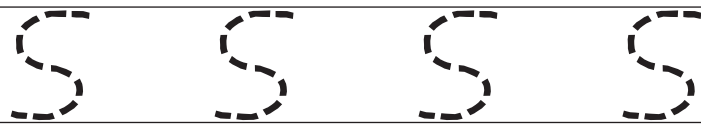
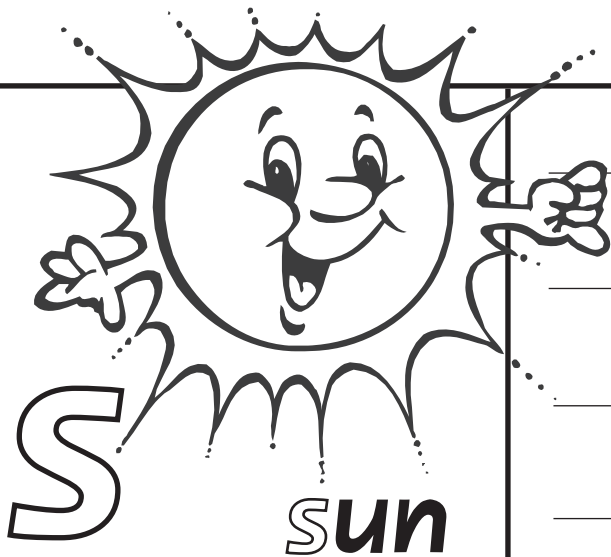

Colour the pictures that start with s.

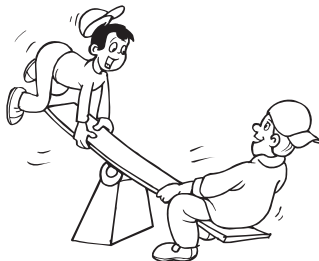
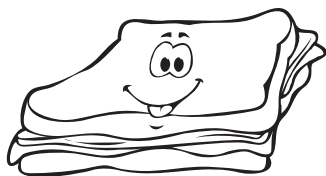
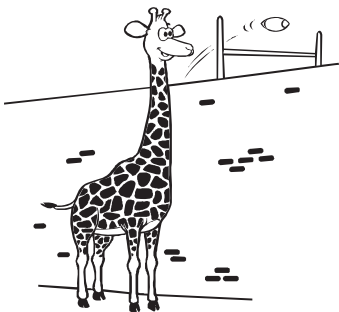
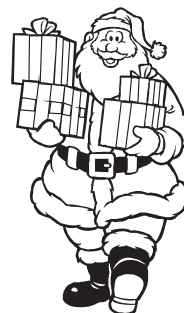
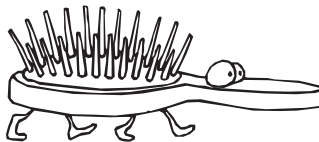
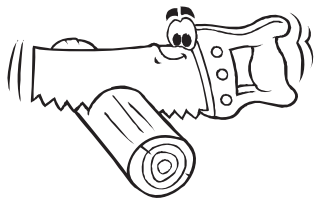

Trace the saucepan and colour the sausages.  
Read the sentence and trace the s sounds.

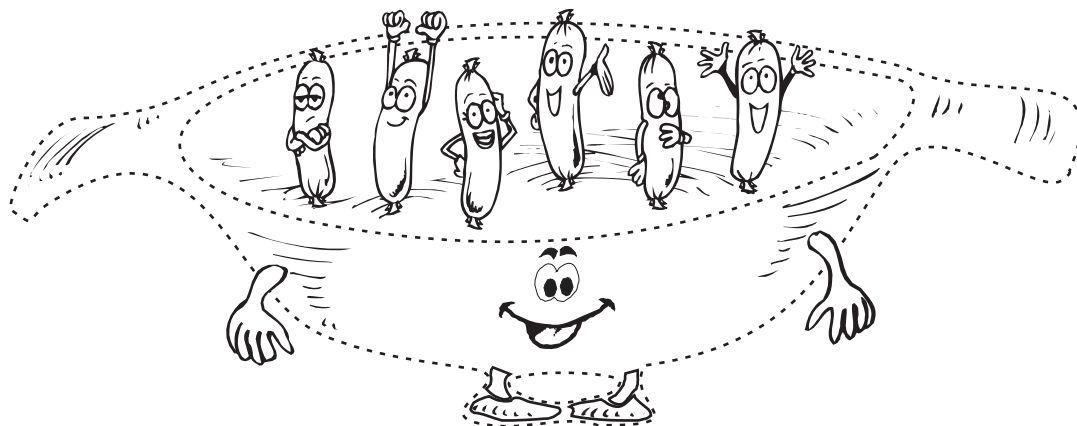

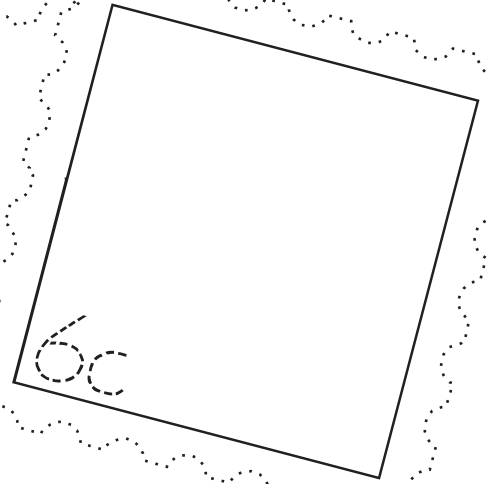
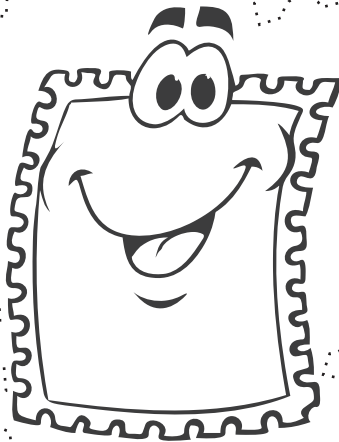
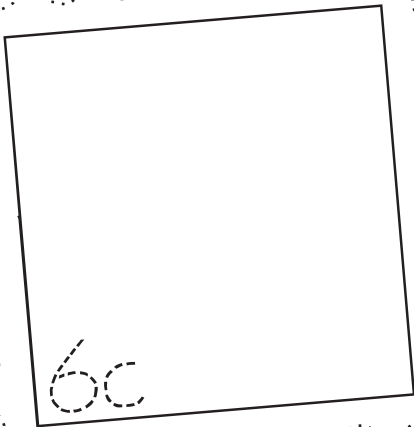
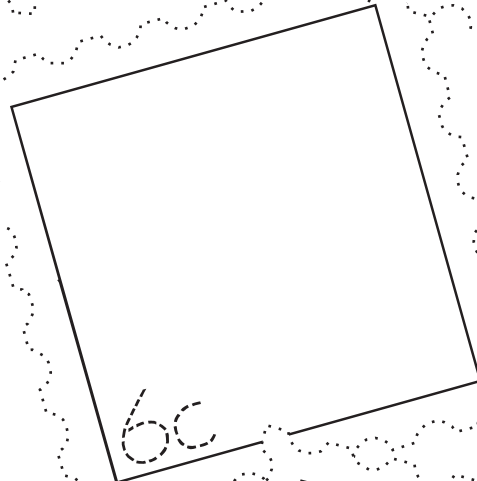
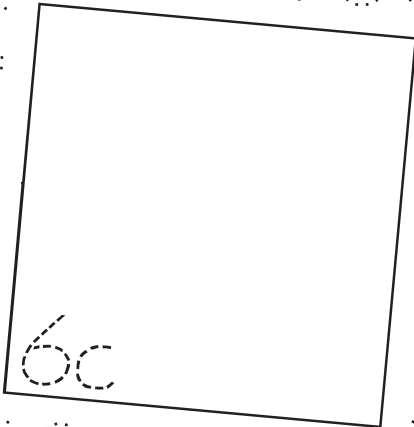
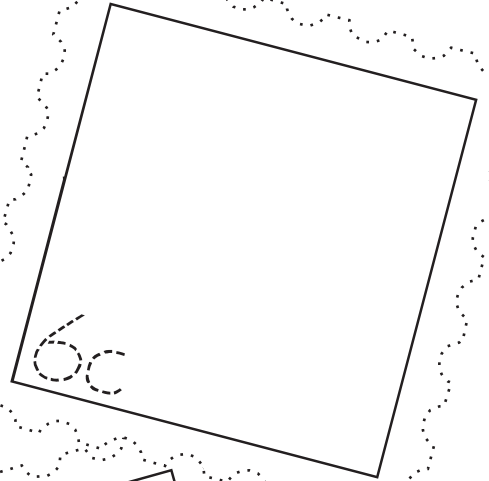
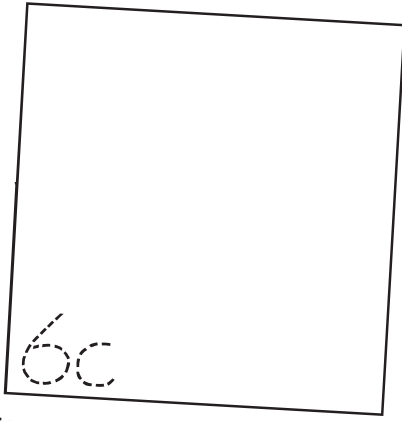

Six s sausages sizzling in the s saucepan.

S S



**There are six stamps.**

-  On each stamp draw a picture of something starting with **s** or cut out pictures from magazines e.g. sandals, snake, snail, sandwiches, sausage, seaweed etc.
-  Trace over the outside of each stamp in a different colour.
-  Trace over the **s** sounds in the sentence.

# s S

1. Colour the pictures that start with s.
2. Trace the s words.



sailor

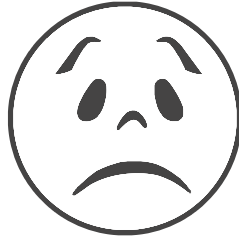

sad

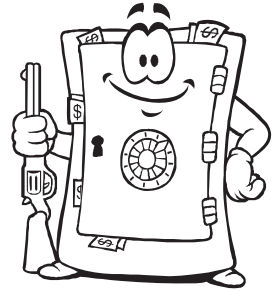

safe



plant

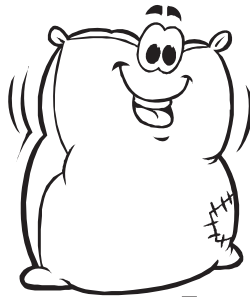

sack

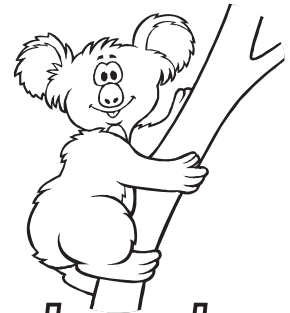

koala

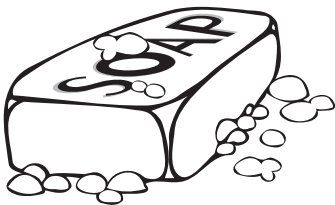

soap

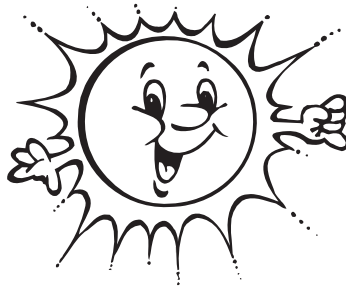

sun

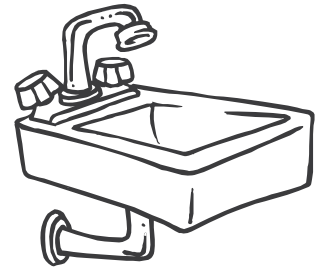

sink

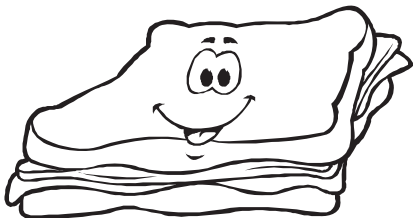

sandwich

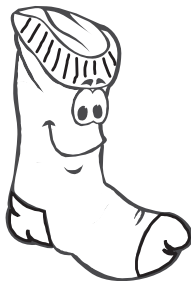

sock

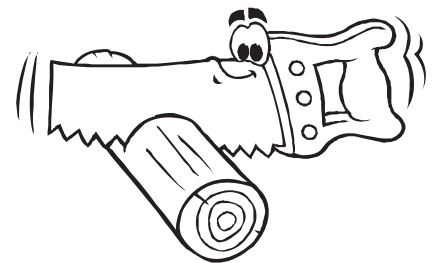

saw

Write some s words on another sheet  
or find some s pictures in magazines or newspapers.



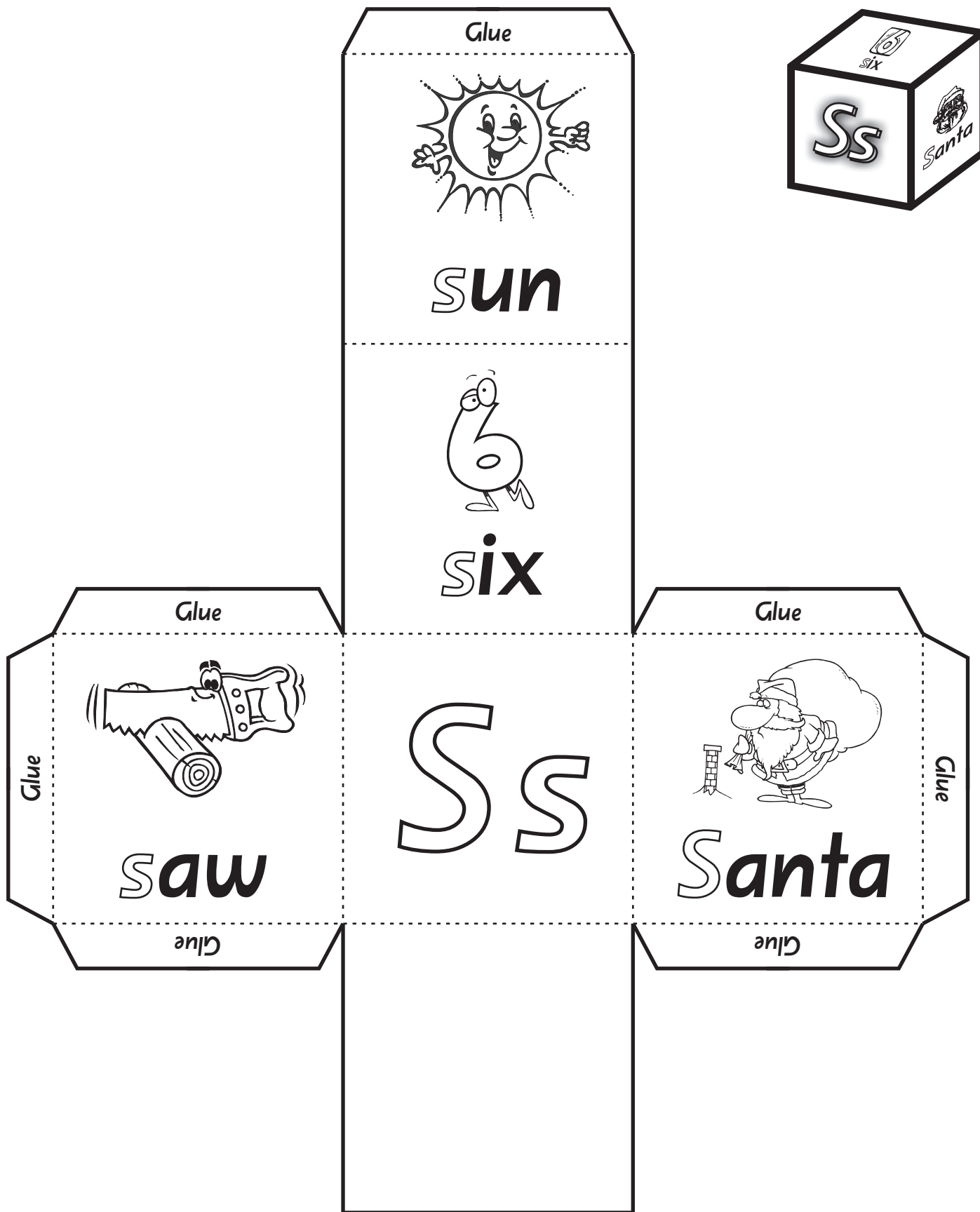

Colour in the big Ss sounds.



Colour the s pictures.



Trace over the s sounds in the words.



Draw your own s picture in the blank square.

Cut along the straight lines and fold along the dotted lines. Glue it together to make a cube.



Trace any *s* sounds. Colour any picture that starts with *s*.

S

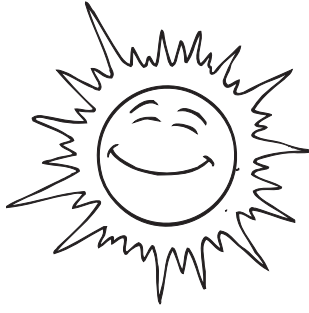

e

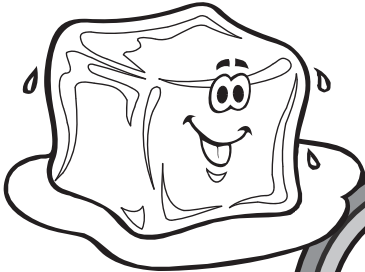

S

S

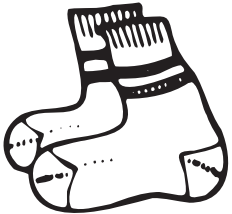

sack

a

S

Draw your own *s* picture.

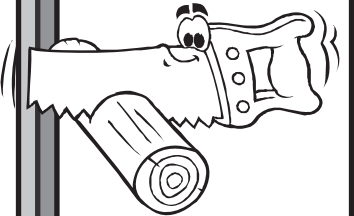
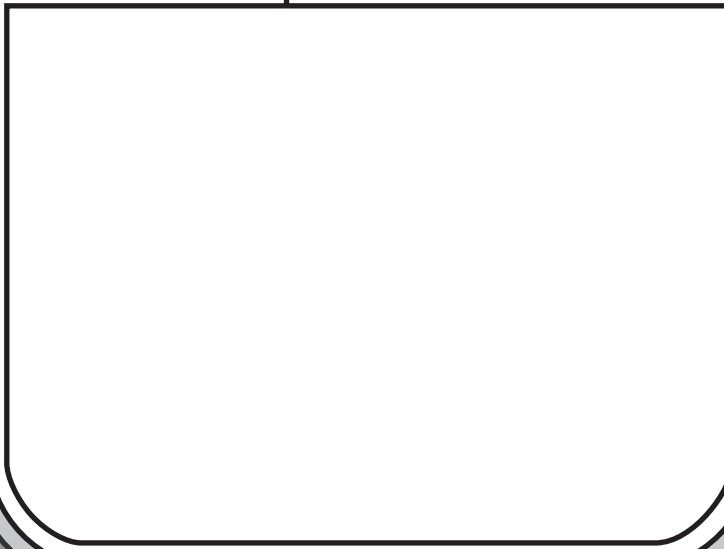

S

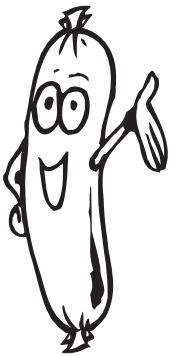

n

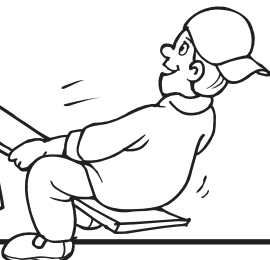

S



S



Draw a line to match the picture and word. Write the sound.

ss



ack

alt

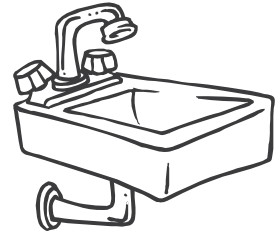

ink

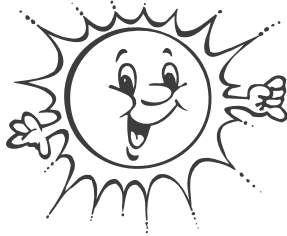

un



ad



Circle the words that start with s.

sit rip sing rang sang

save sap sell sunk so

day say said read sold

There are  s words.

Colour the pictures that start with s.

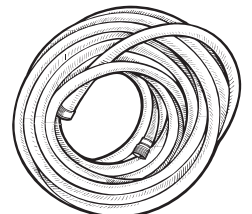
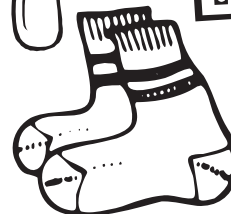
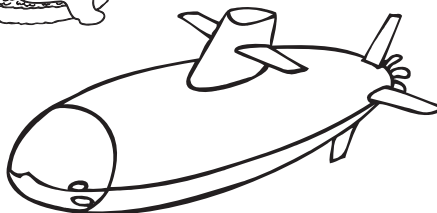
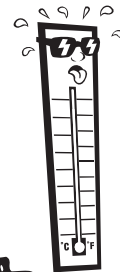
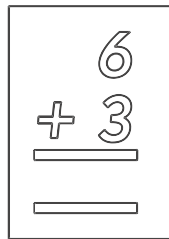
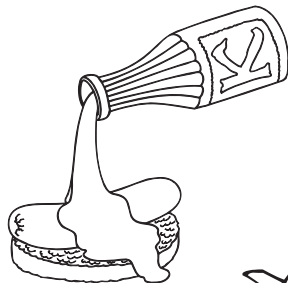
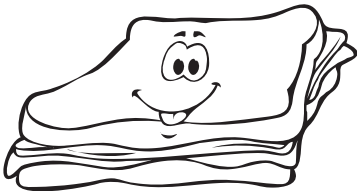

S  
S

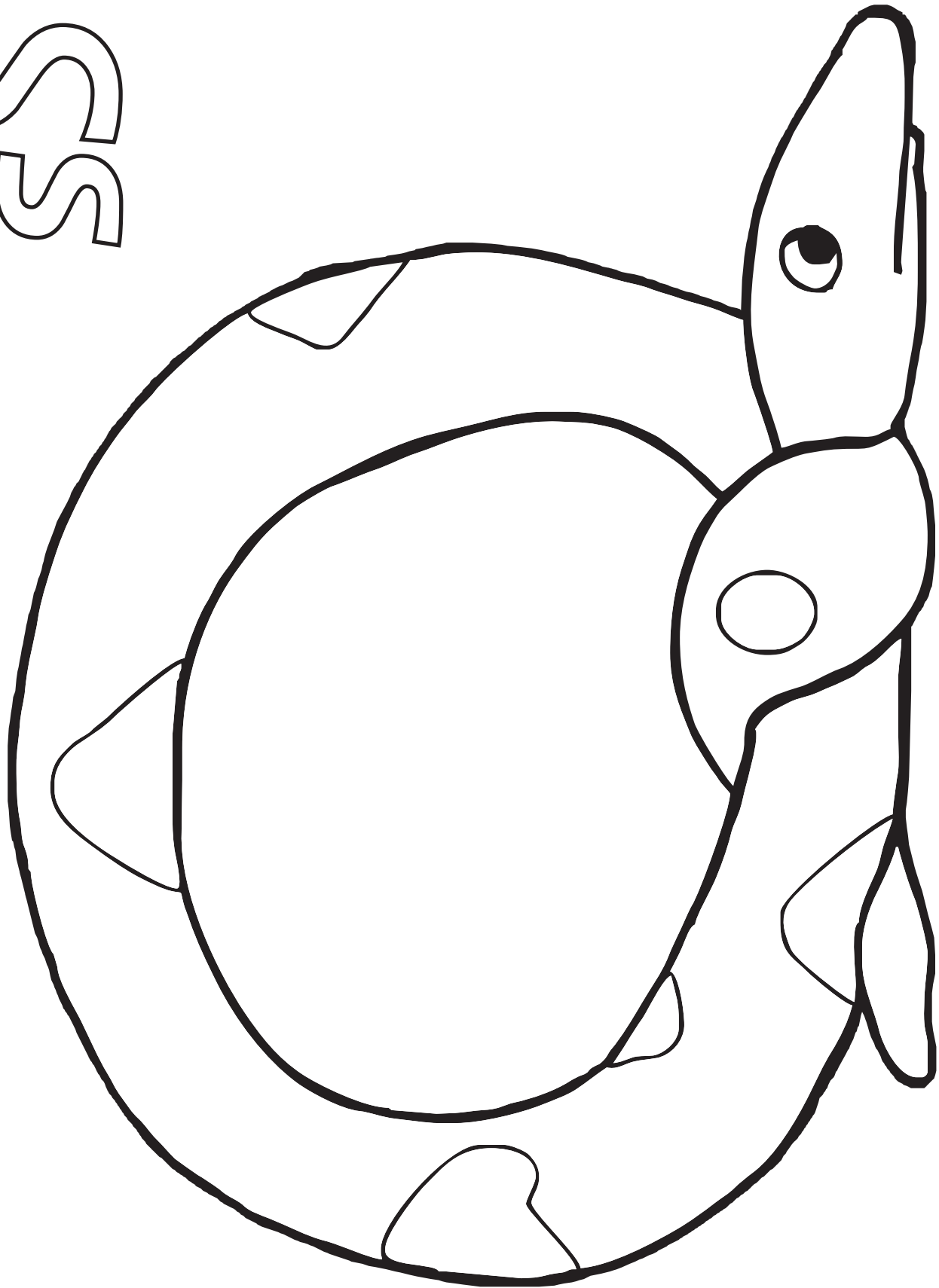

**PICK A  
CRAFT  
IDEA**



- 1** Colour and cut out the snake. Apply a green wash to some art paper. Dip the edge of some cardboard in green paint and print grass. Paste the snake on the paper.
- 2** Fill the inside of the snake with *s* words or *s* letters and then colour. Paste two snakes back to back to make a mobile.
- 3** Make a long snake to stretch the length of the classroom or more. Write *s* words all along the body.

Trace the † sounds.

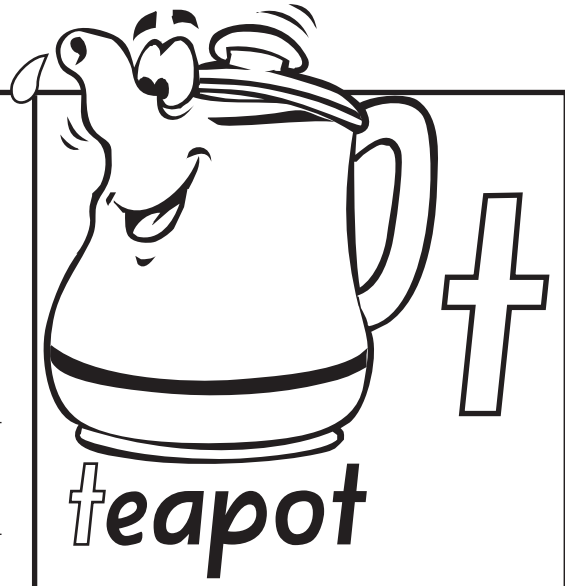
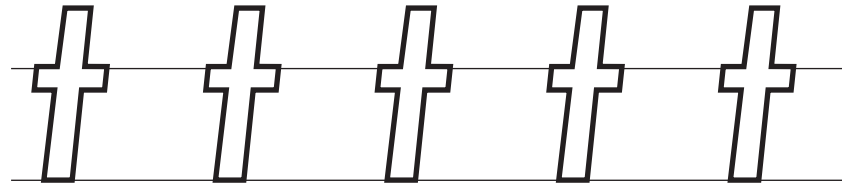
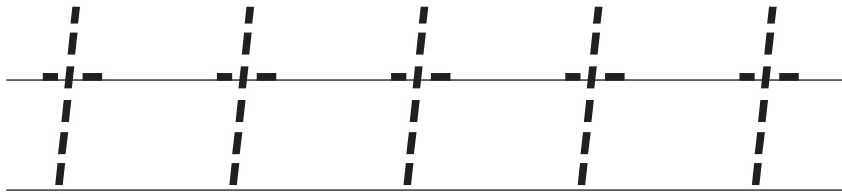

Colour the pictures that start with †.

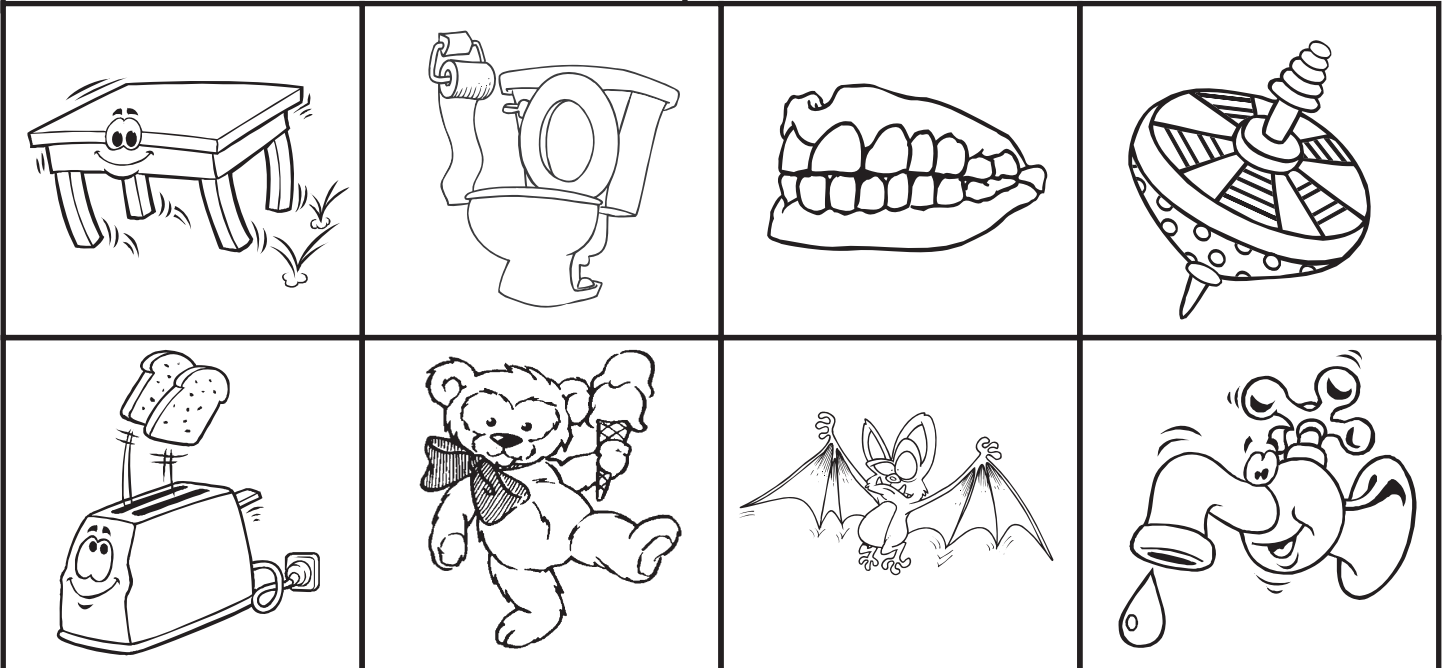

Trace the tortoise shells and colour the picture.  
Read the sentence and trace the † sounds.

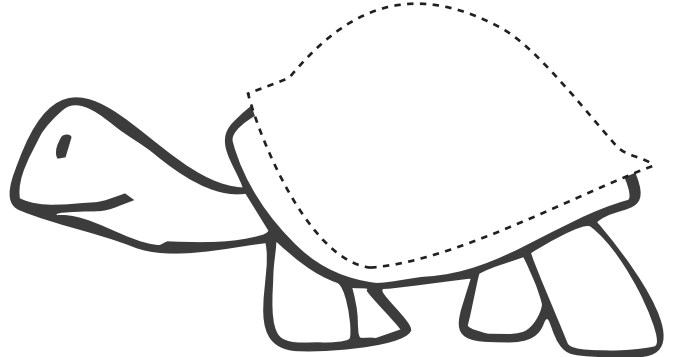
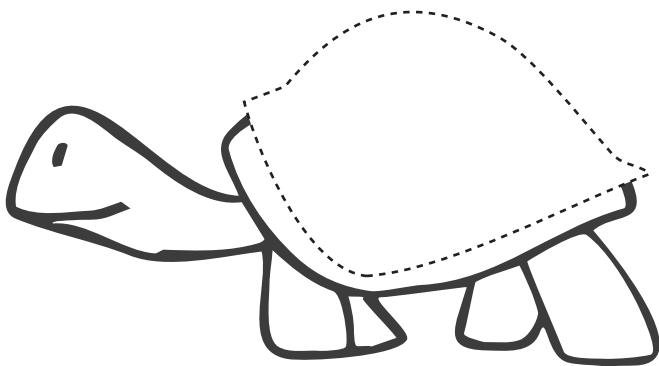

The †ortoises are †aking †urns.

t T

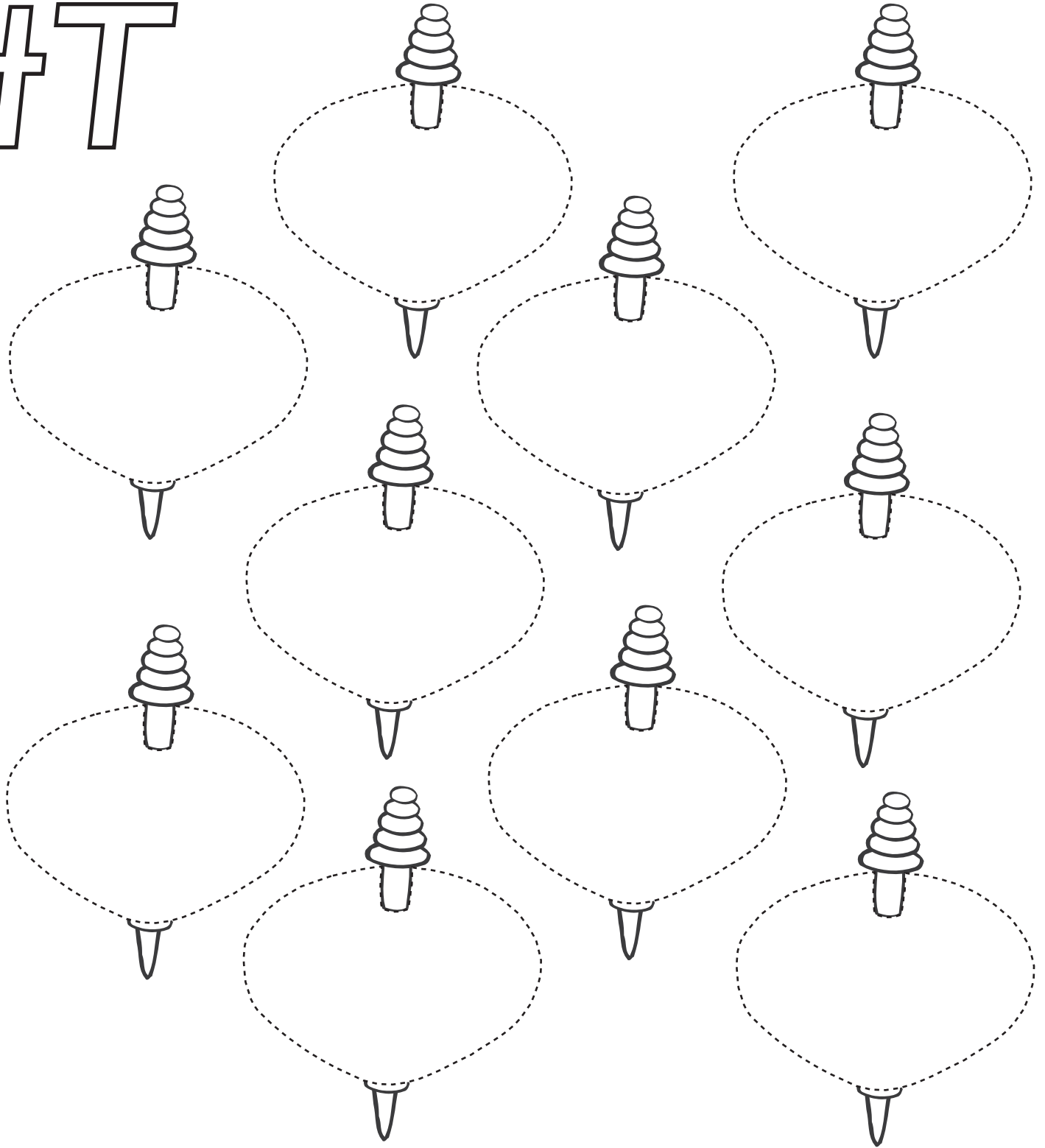

Ten t tops t turning.

- ☺ Trace over the ten turning tops.
- ☺ Colour them brightly.
- ☺ Trace over the t sounds in the sentence.

# t T

1. Colour the pictures that start with t.
2. Trace the t words.



drum

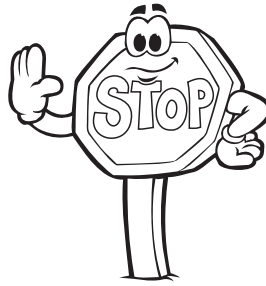

stop



teapot

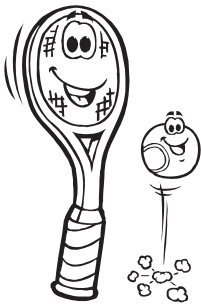

tennis



tail



tent

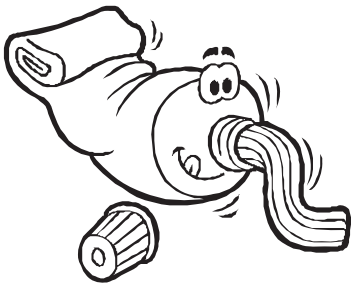

toothpaste

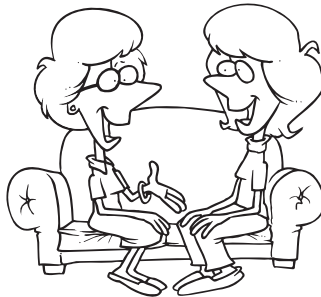

talk

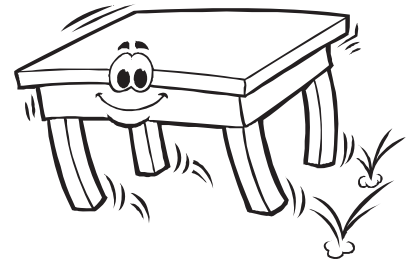

table



tap

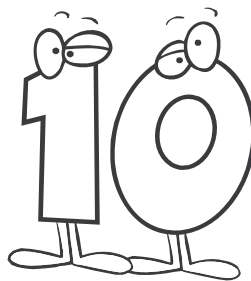

ten



tiger

Write some t words on another sheet  
or find some t pictures in magazines or newspapers.



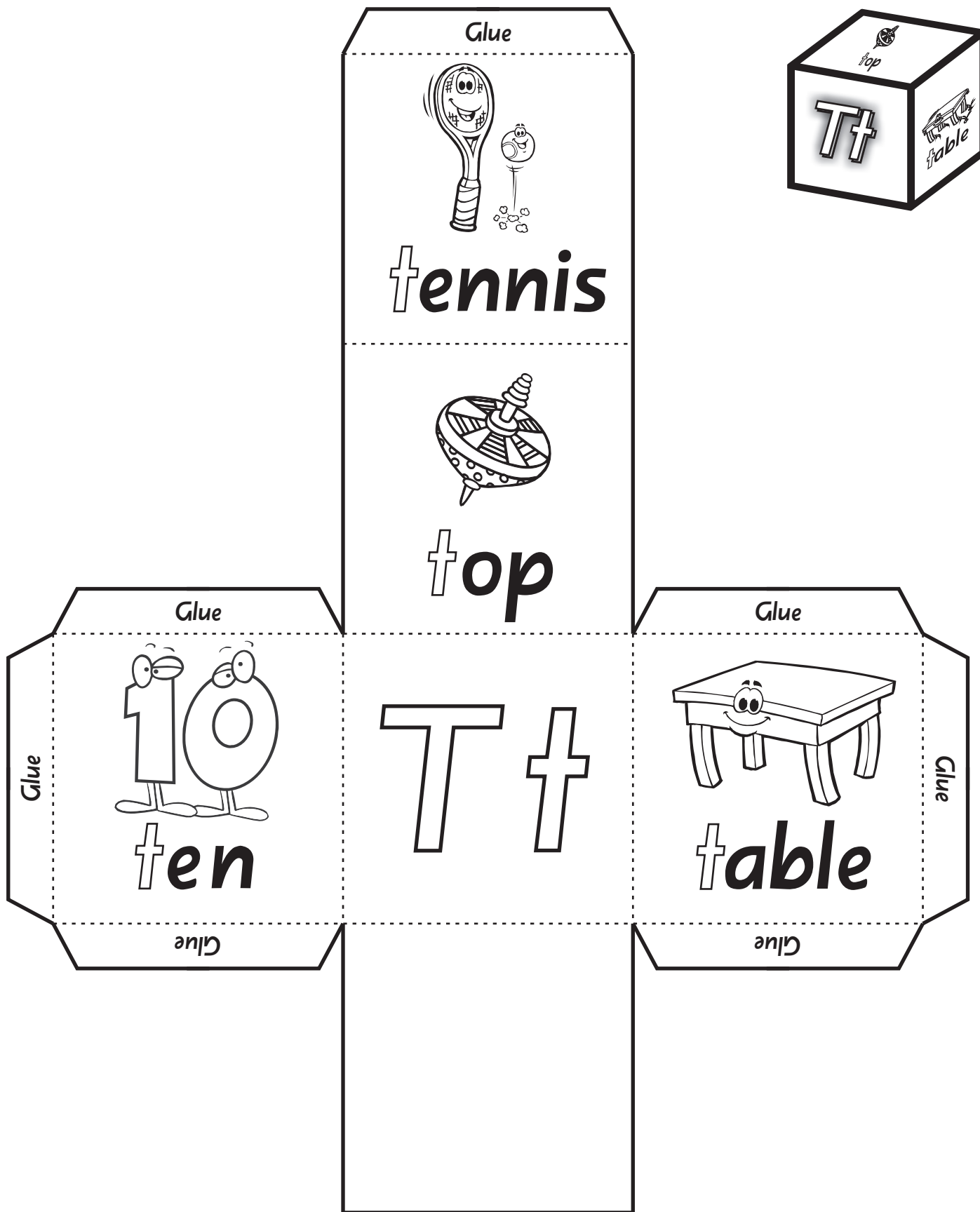

Colour in the big Tt sounds.



Colour the t pictures.



Trace over the t sounds in the words.



Draw your own t picture in the blank square.

Cut along the straight lines and fold along the dotted lines. Glue it together to make a cube.



Trace any † sounds. Colour any picture that starts with †.

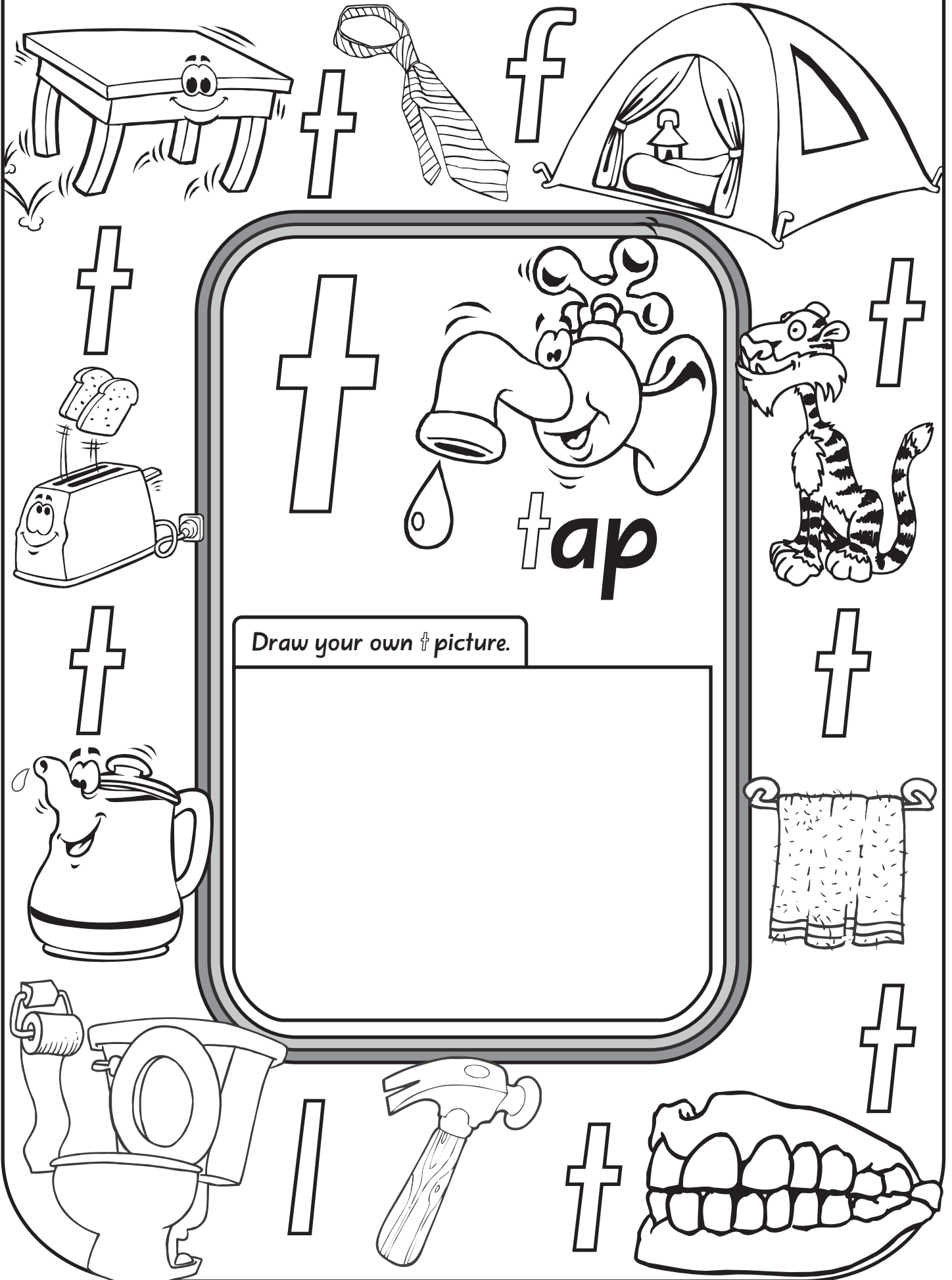

t T

Draw a line to match the picture and word. Write the sound.

□ toast

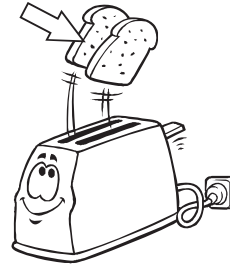

□ tail



□ tin

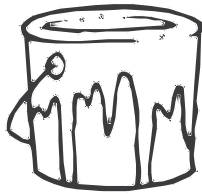

□ tie

□ toes

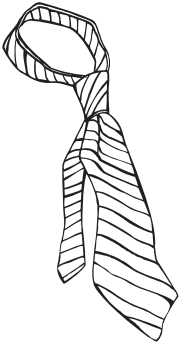

Circle the words that start with t.

rack tank taxi tan to

hot two ten name tug

tower hips town tired

There are  t words.

Colour the pictures that start with t.

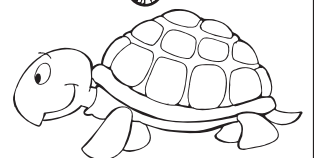
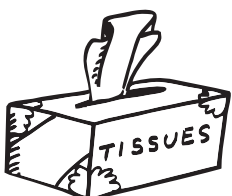
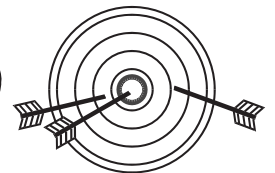
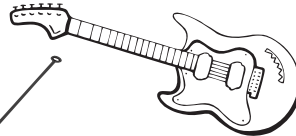
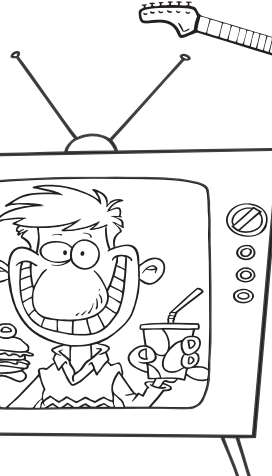
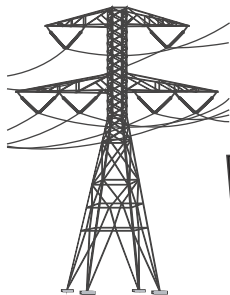

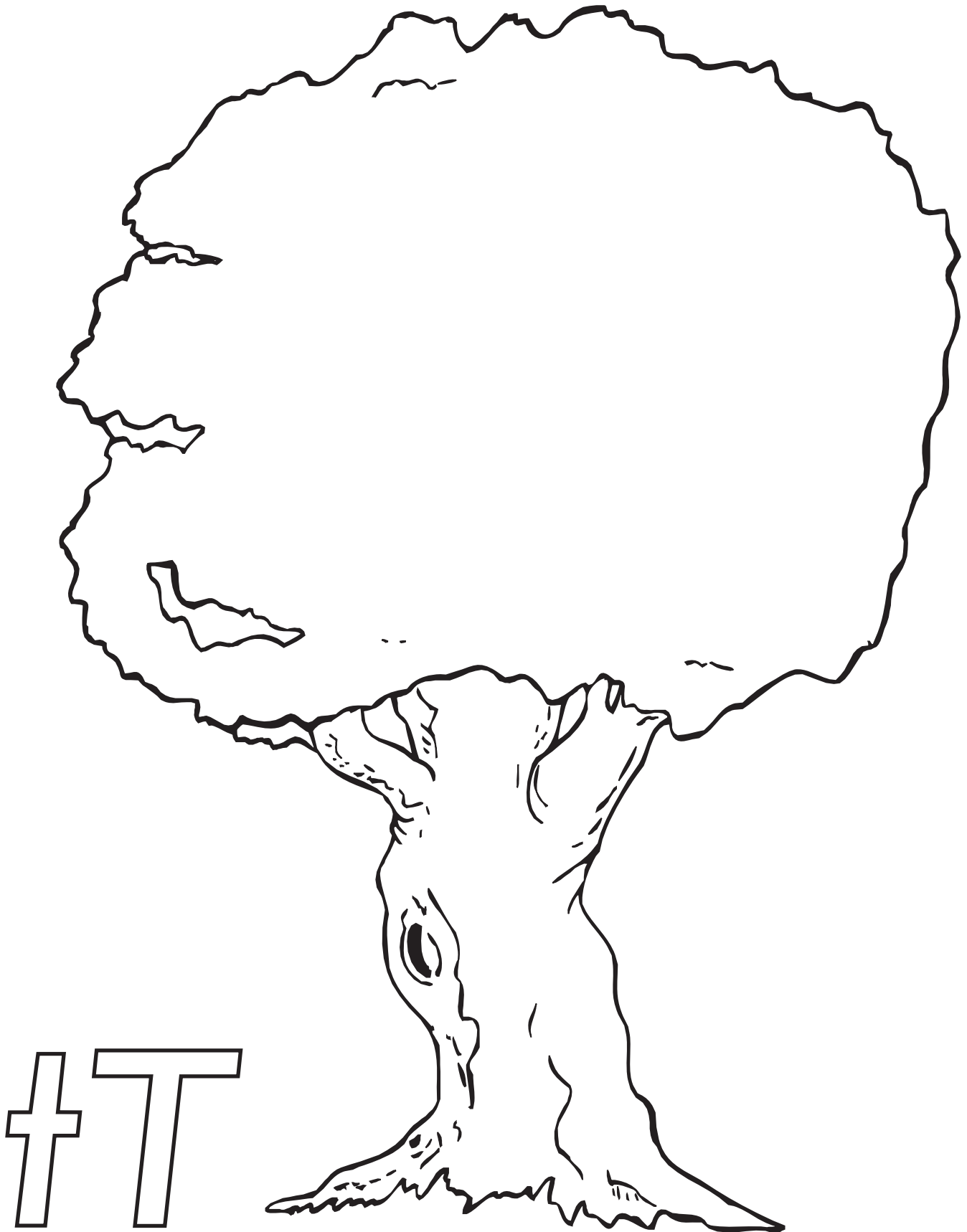

- 1** Fill the tree with † words and then colour and cut out. Paste all of the trees together into a forest of † trees.
- 2** Use finger painting to print leaves on the tree e.g. pink and bright green for a spring tree; green for summer; red, orange, brown and yellow for autumn.
- 3** Fill the tree with † words or letters and add colour. For a variation write the words on leaf-shaped paper. For an autumn tree place them at the base.

U



umbrella

Trace the u sounds.



Colour the pictures that start with u.

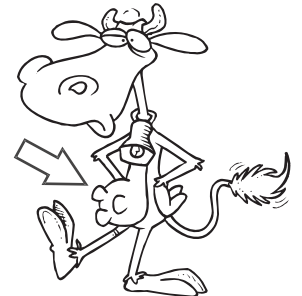
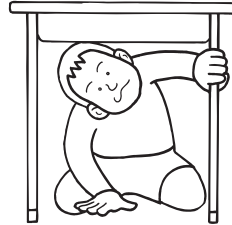
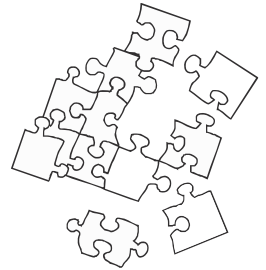
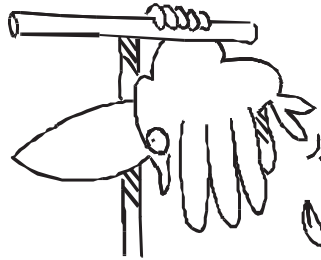
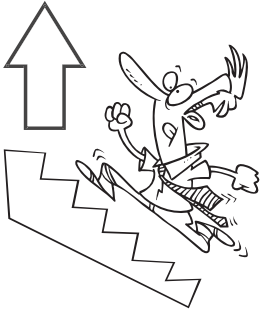



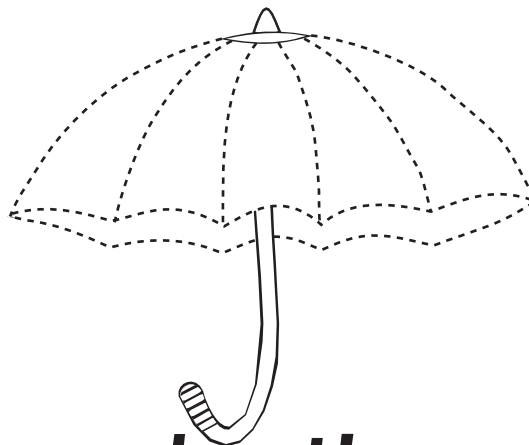

Trace the umbrella and draw something under the umbrella.  
Read the sentence and trace the u sounds.

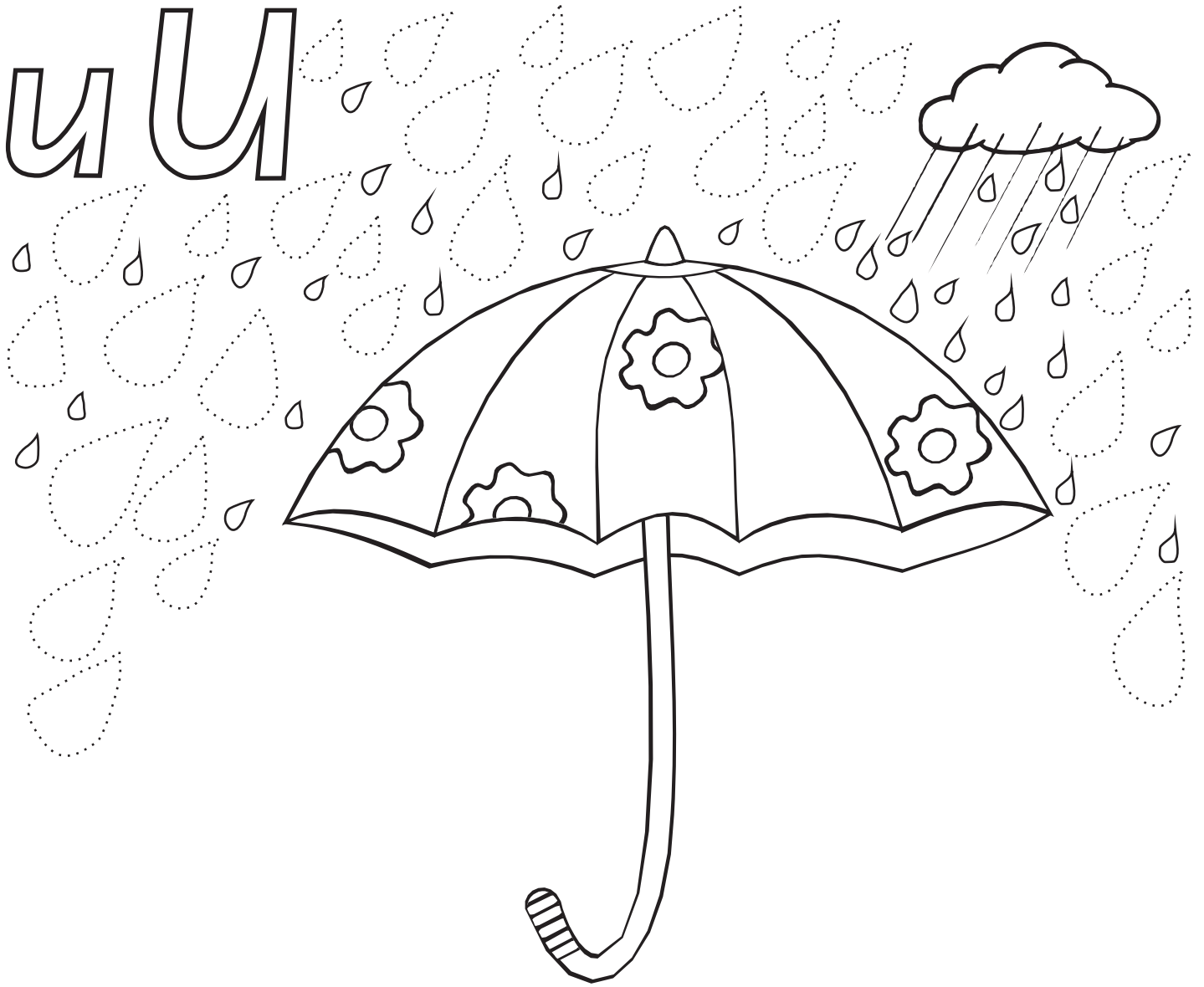

What is under the umbrella?



## Who is under the umbrella?

-  Draw someone or something under the umbrella.
-  Colour the umbrella in bright colours.
-  Trace over the raindrops and shade the background grey.
-  Trace over the u sounds in the sentence.

# u u

1. Colour the pictures that start with u.
2. Trace the u words.



scooter

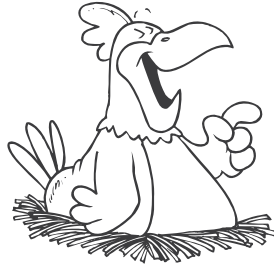

hen



under

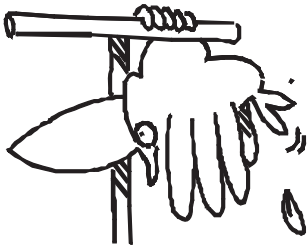

upside-down

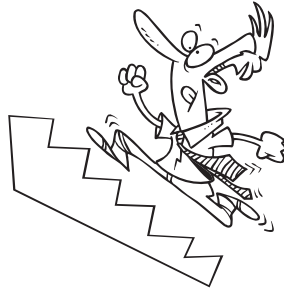

upstairs

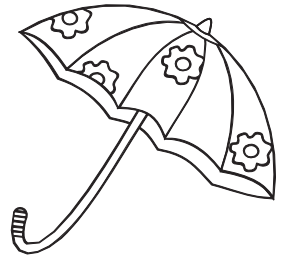

umbrella



ugly

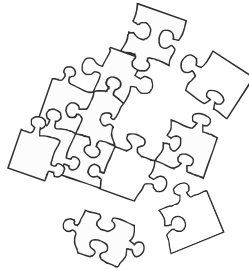

undo

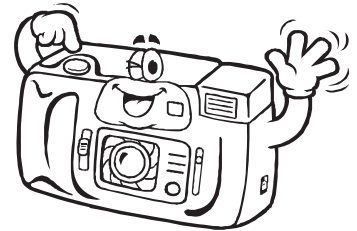

camera



books

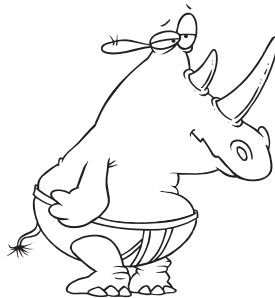

underpants

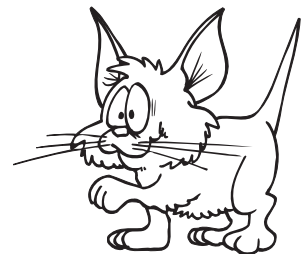

cat

Write some u words on another sheet  
or find some u pictures in magazines or newspapers.



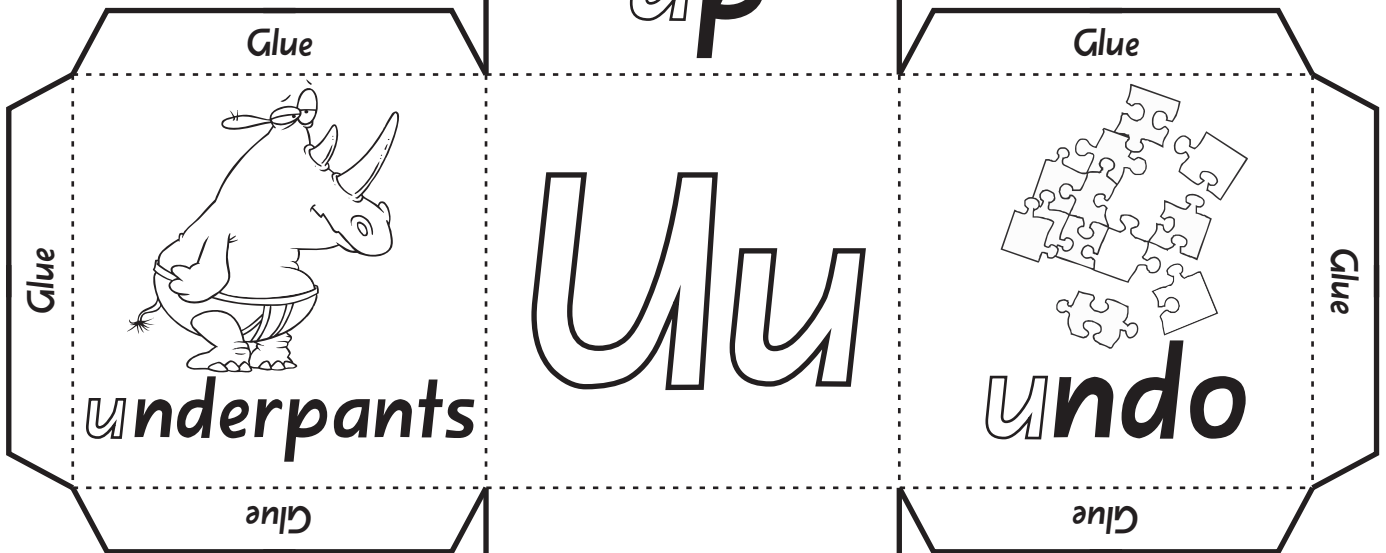
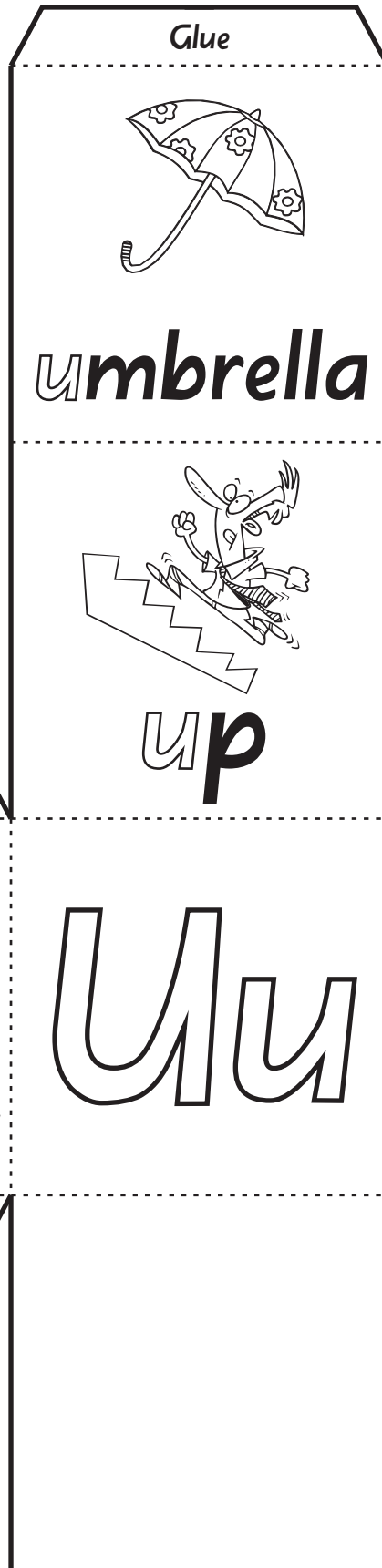
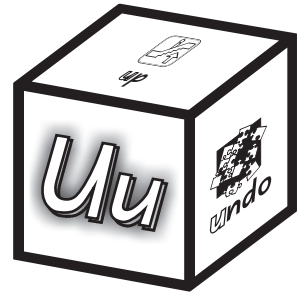

Colour in the big **Uu** sounds.



Colour the **u** pictures.



Trace over the **u** sounds in the words.



Draw your own **u** picture in the blank square.

Cut along the straight lines and fold along the dotted lines. Glue it together to make a cube.



Trace any u sounds. Colour any picture that starts with u.



g

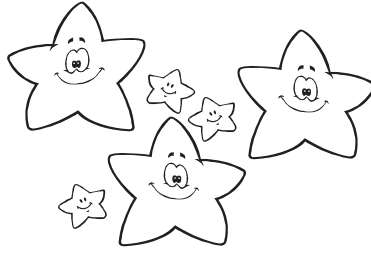

u



u

u

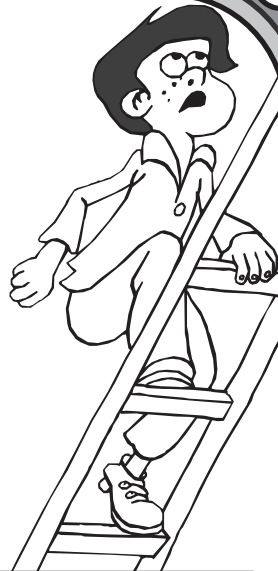

u

up

Draw your own u picture.

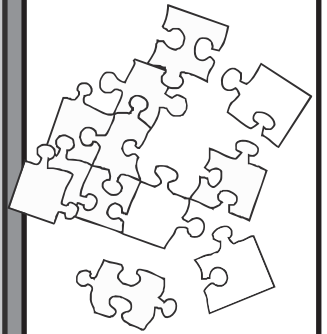
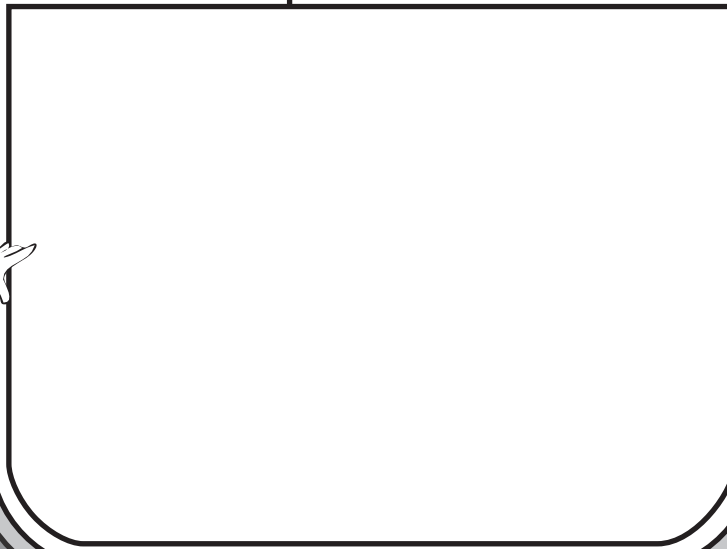

u

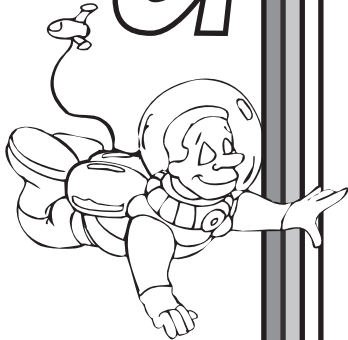
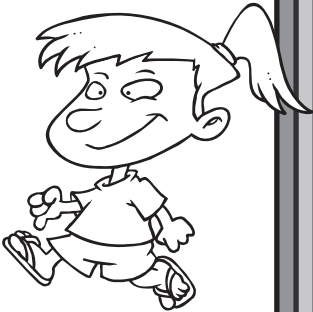

u

u

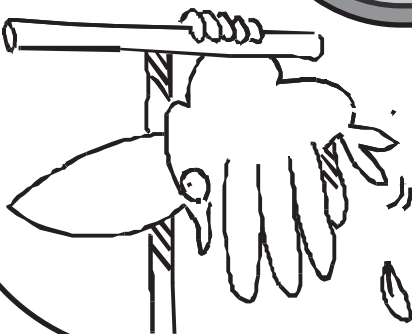

h



u

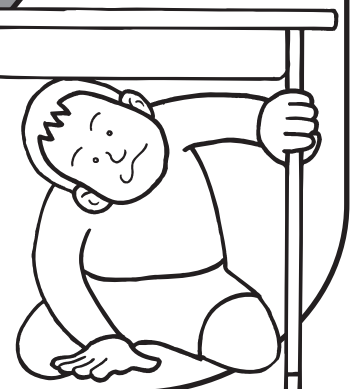

Draw a line to match the picture and word. Write the sound.

u U

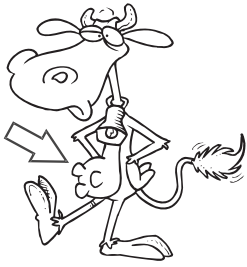

mbrella

ndo

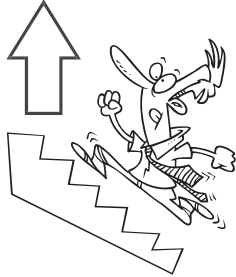

nder

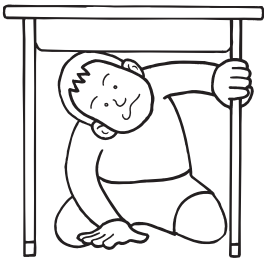

p

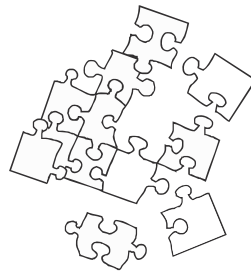

dder

Circle the words that start with u.

ugly

under

note

undo

ulcer

undone

star

unkind

unmade

truck

unsafe

There are  u words.

Colour the pictures that start with u.

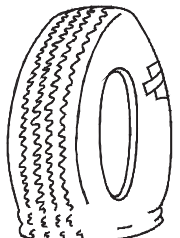
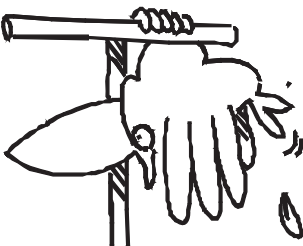
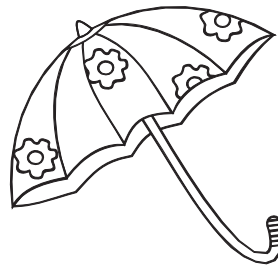

u u



**PICK A  
CRAFT  
IDEA**



- 1** Colour the umbrella and cut out. Paste onto a person in a raincoat and hat. Colour the background and add raindrops and puddles.
- 2** Write *u* words in large raindrop shapes. Mount onto the classroom display board with the coloured umbrellas.
- 3** Write *u* words in the umbrella segments and glue two shapes back to back with string in between to make umbrella mobiles.

Trace the *u* sounds.

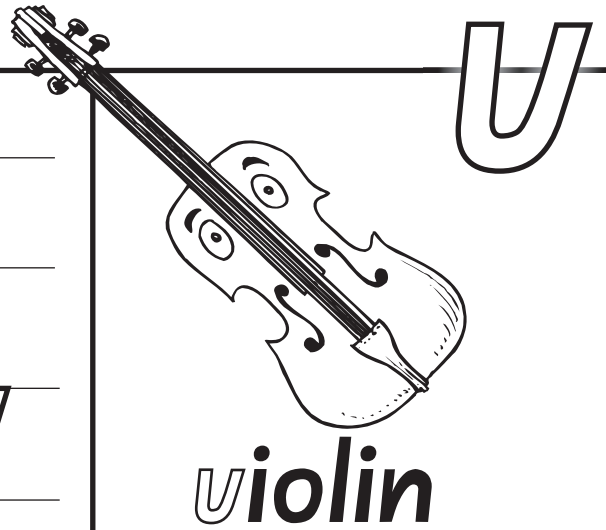
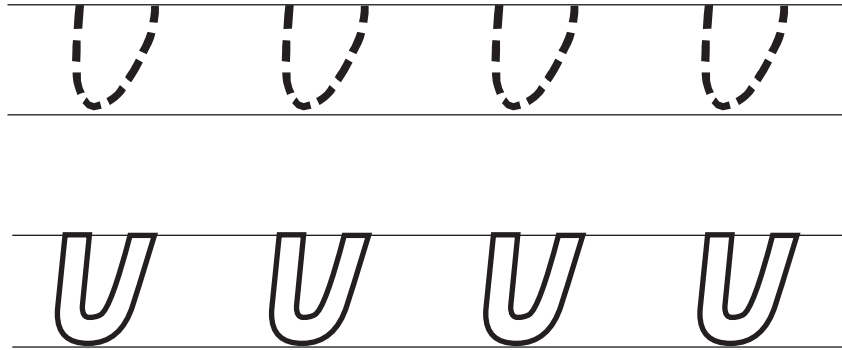

Colour the pictures that start with *u*.



Trace the vases and draw two flowers in each one.  
Read the sentence and trace the *u* sounds.

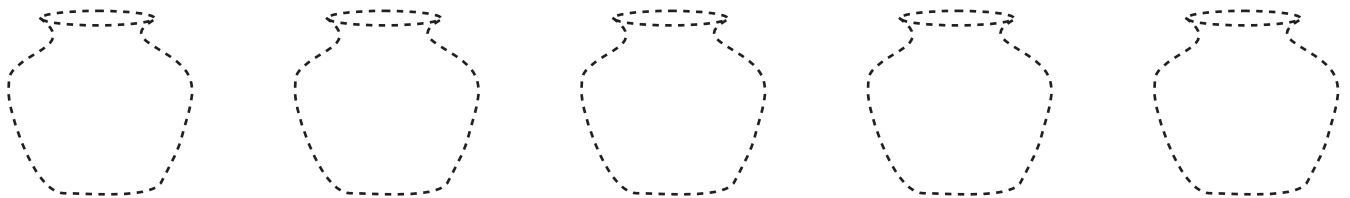





**The *u*iolets are in a *u*ase.**

u v



***There are seven violets in the vase.***

-  ***Cover the vase with chips of coloured paper or use fingerprinting with different colours to decorate the vase.***
-  ***Draw ten flowers in the vase.***
-  ***Colour seven of the flowers purple and use some other colours for the rest.***
-  ***Trace over the v sounds in the sentence.***

# u v

1. Colour the pictures that start with *u*.
2. Trace the *u* words.

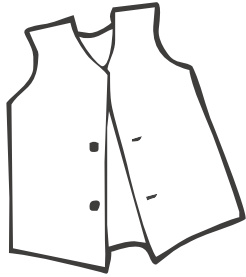

vest

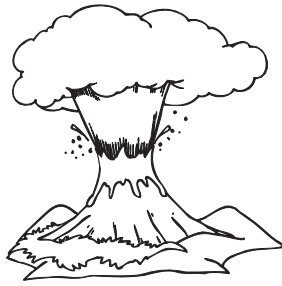

volcano

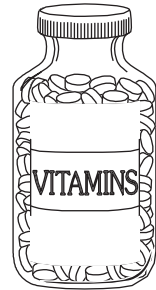

vitamins

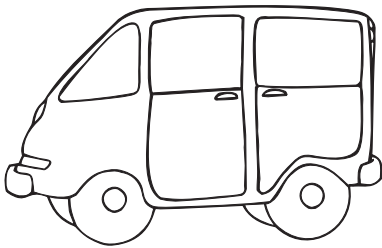

van



ice block



paper clip



vacuum

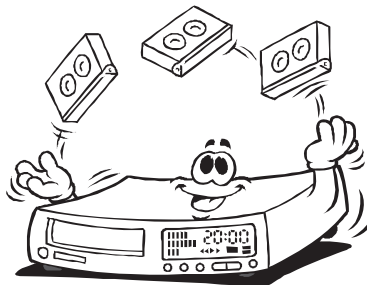

video

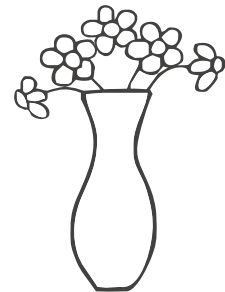

vase

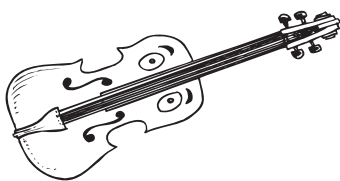

violin



wolf





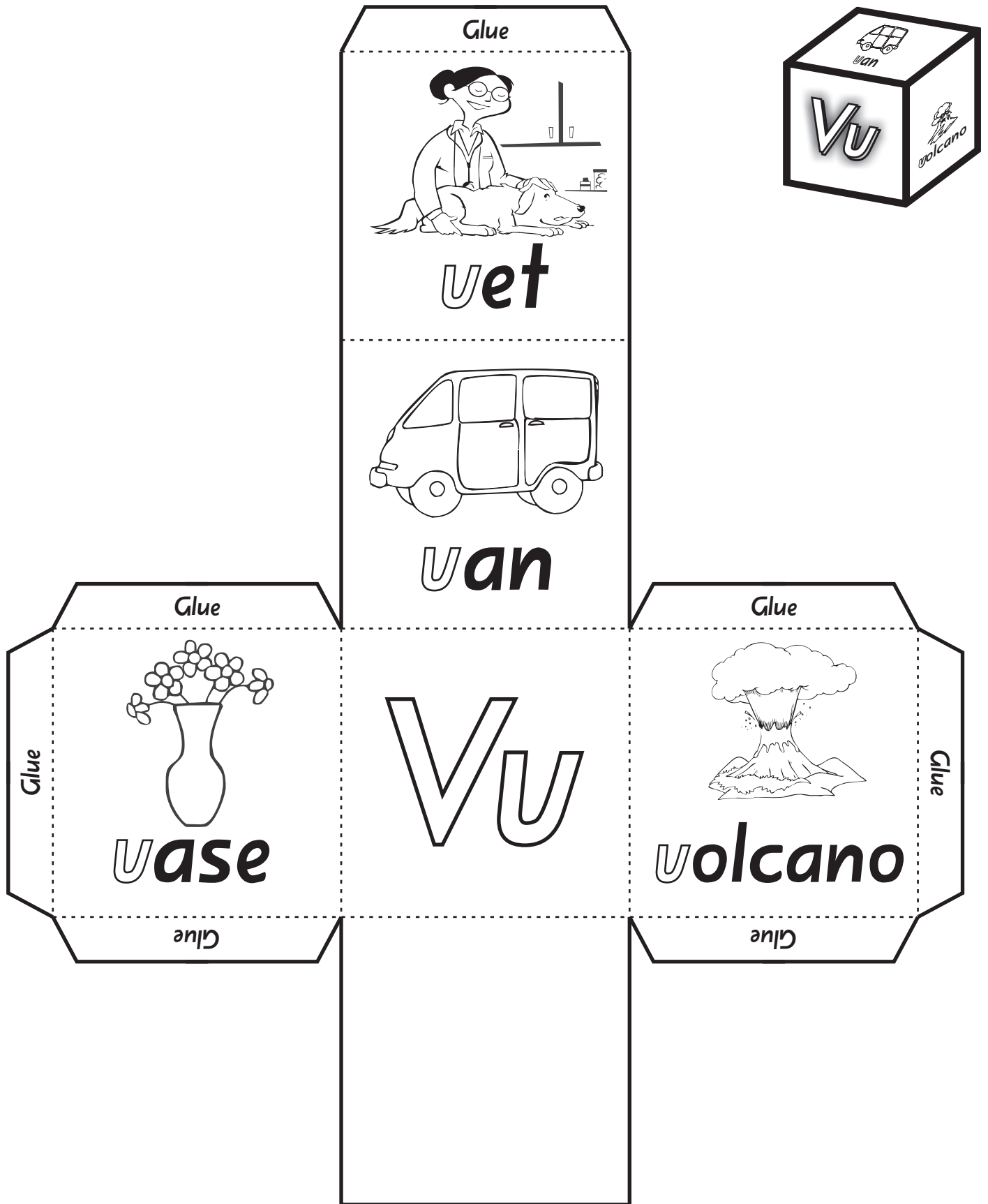

vet

Write some *u* words on another sheet  
or find some *u* pictures in magazines or newspapers.





-  Colour in the big **Vv** sounds.
-  Colour the **v** pictures.
-  Trace over the **v** sounds in the words.
-  Draw your own **v** picture in the blank square.

Cut along the straight lines and fold along the dotted lines. Glue it together to make a cube.



Trace any *u* sounds. Colour any picture that starts with *u*.

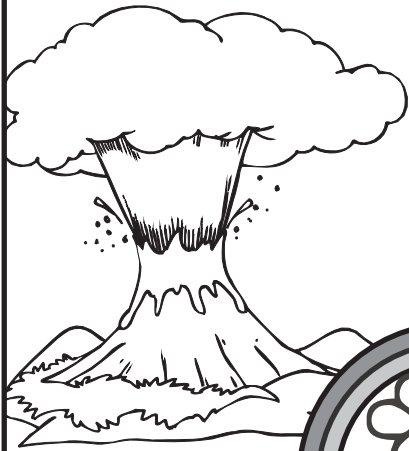

U

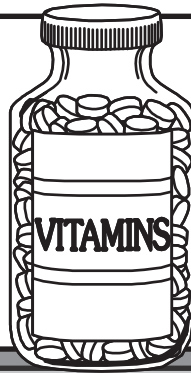

U

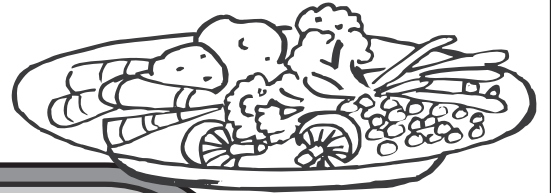

U

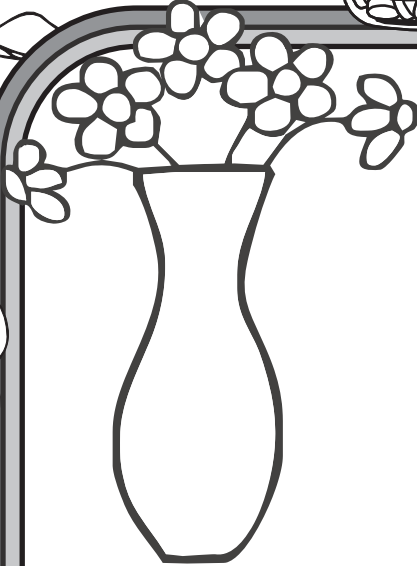

U

**vase**



U



Draw your own *u* picture.

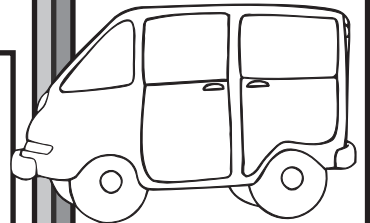

U

U

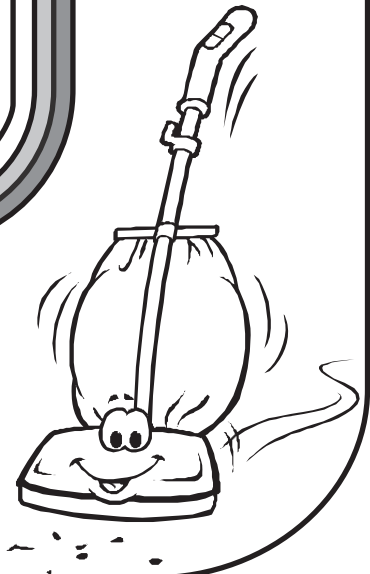
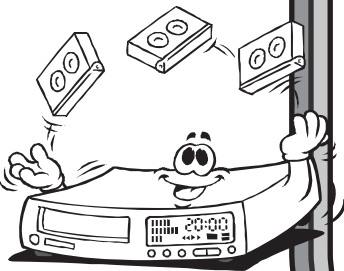

U

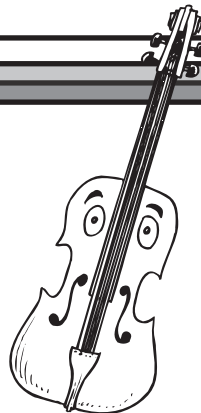

U

u v

Draw a line to match the picture and word. Write the sound.

egetables

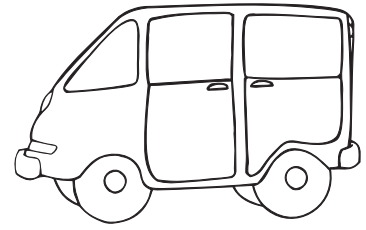

an



ine

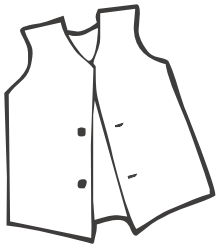

est

acuum

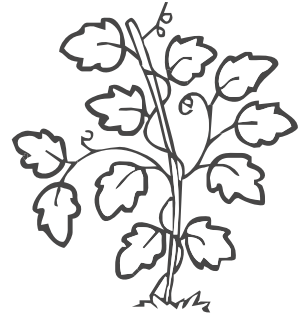

Circle the words that start with u.

queen

vase

value

match

vise

vet

victory

vain

vile

vast

mill

viper

veil

There are  u words.

Colour the pictures that start with u.

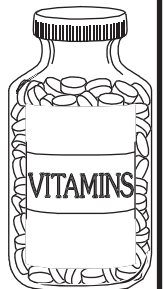
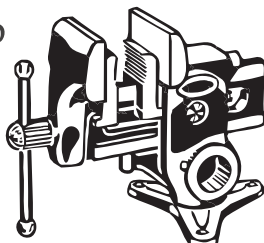
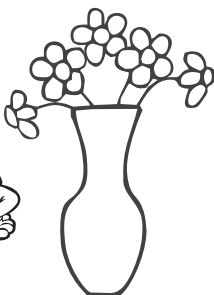
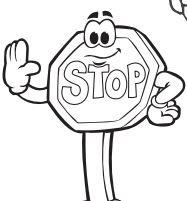
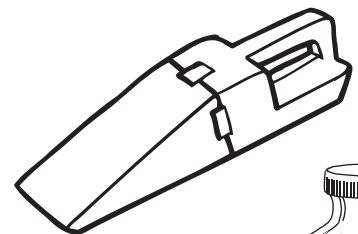
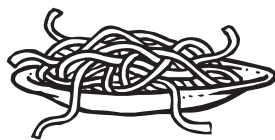
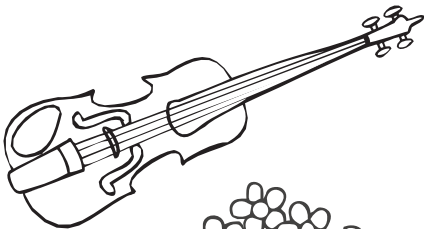

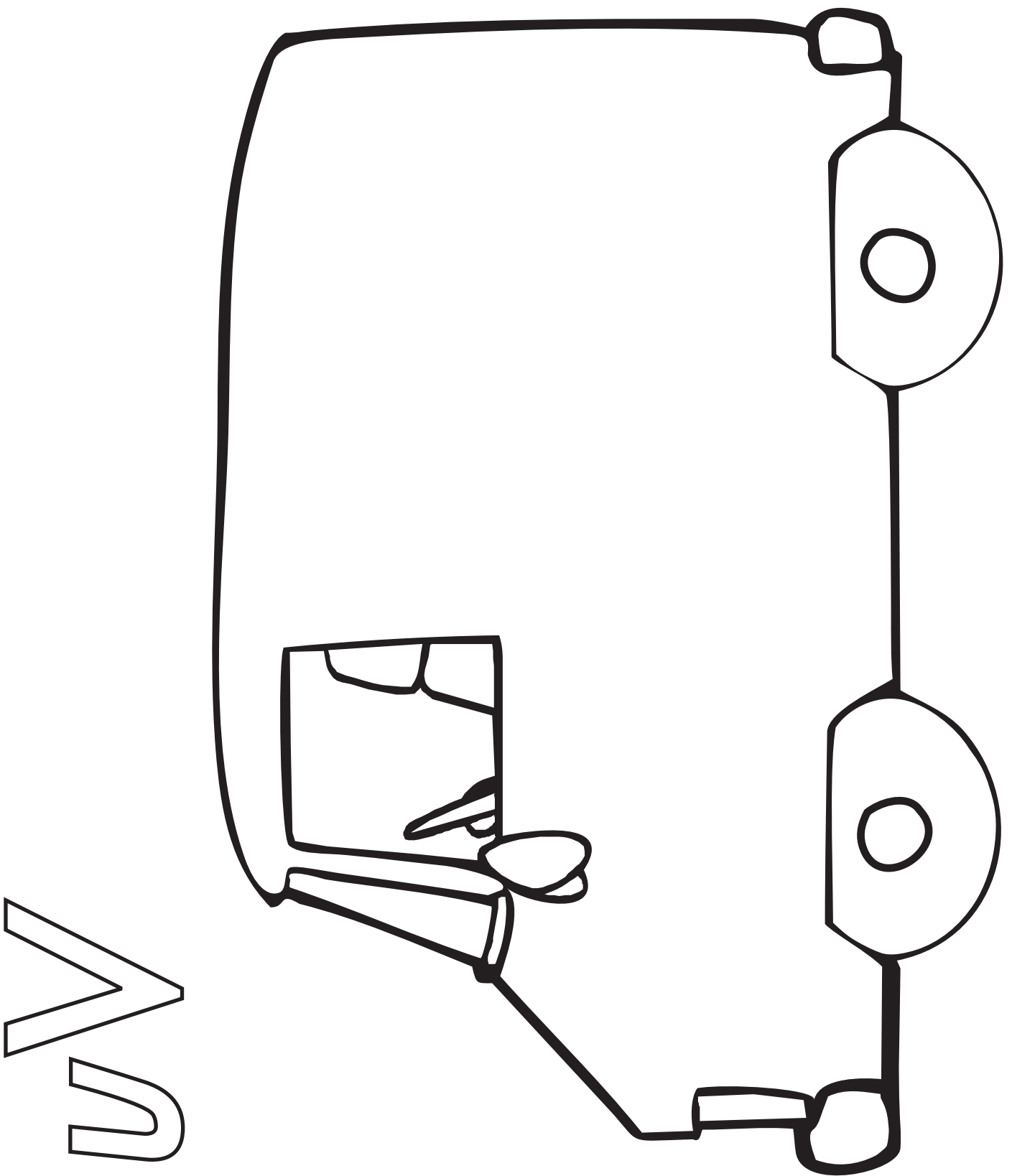

**PICK A  
CRAFT  
IDEA**



- 1** Write *v* words or letters all over the van and then colour it in.  
Cut out the vans and paste together to make a large traffic jam.
- 2** Paint a large background with streets, parking areas etc.  
Paint the vans then cut them out and paste them onto the background.
- 3** Make a vehicle display by colouring the vans and cutting and pasting onto a display. Draw some other vehicles to cut and paste onto the display as well.

Trace the w sounds.

w

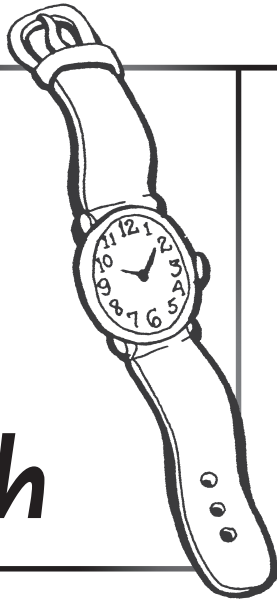

watch



Colour the pictures that start with w.

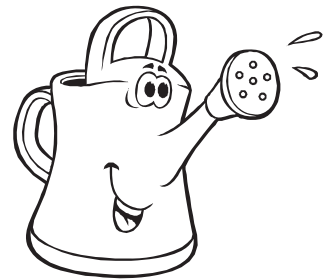
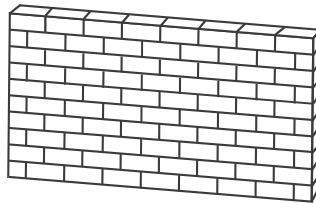
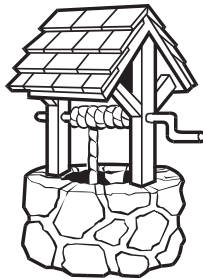
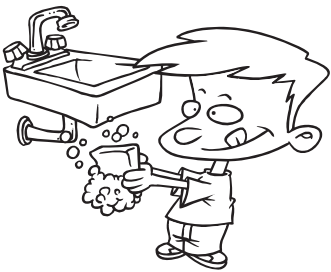
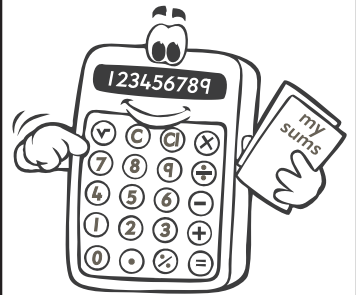
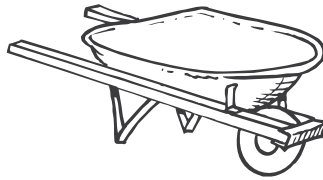
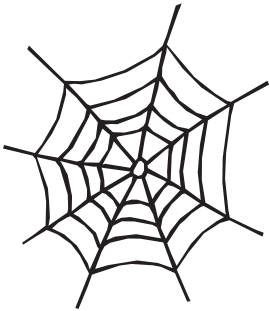

Trace the washing on the line and colour the picture.  
Read the sentence and trace the w sounds.

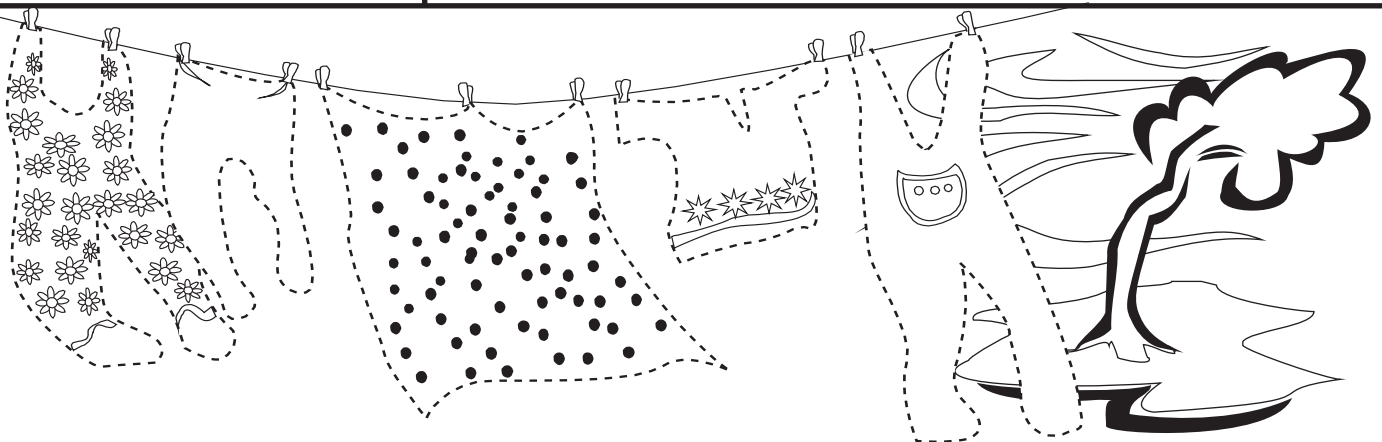

The washing is blowing in the wind.

w W

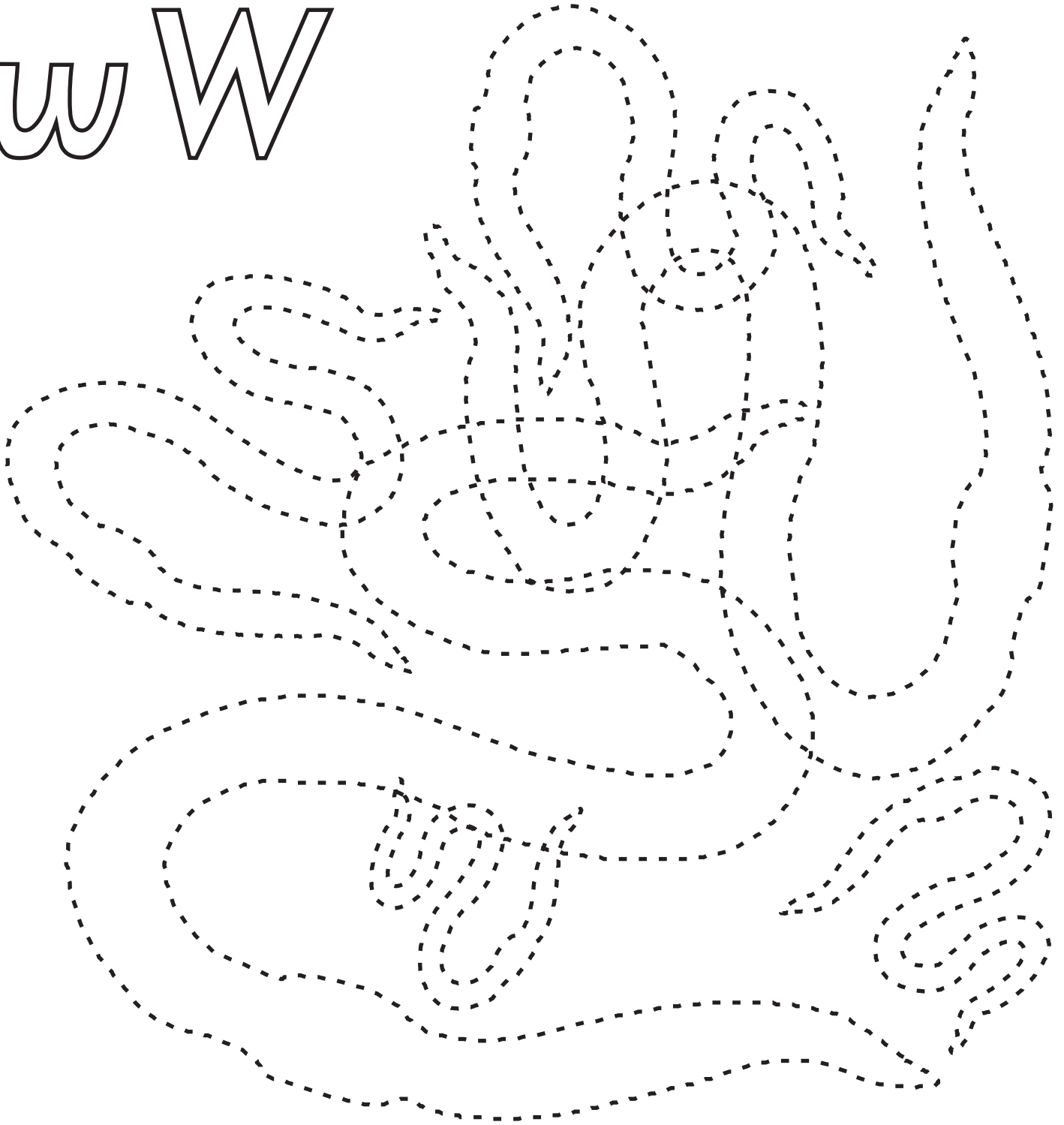

**There are ..... wiggly worms.**



**Trace over the wiggly worms.**



**Colour them all different colours.**



**Count the worms and write the number in the sentence.**



**Trace over the *w* sounds in the sentence.**

# w W

1. Colour the pictures that start with *w*.
2. Trace the *w* words.

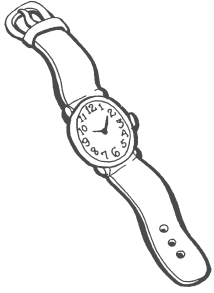

watch

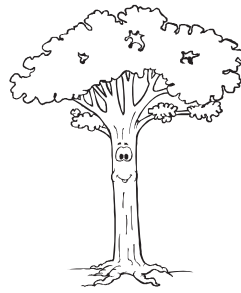

tree



wing

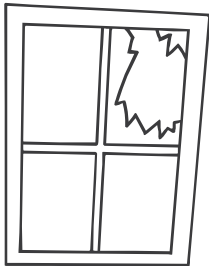

window

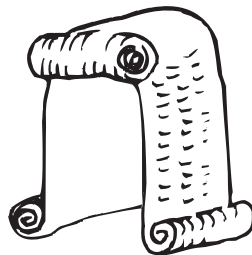

wig



walrus



shovel



wallet

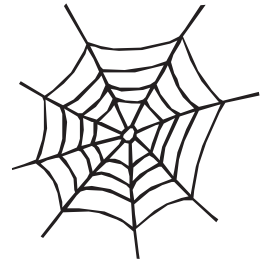

web

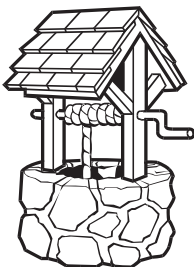

well



wash



witch

Write some *w* words on another sheet  
or find some *w* pictures in magazines or newspapers.



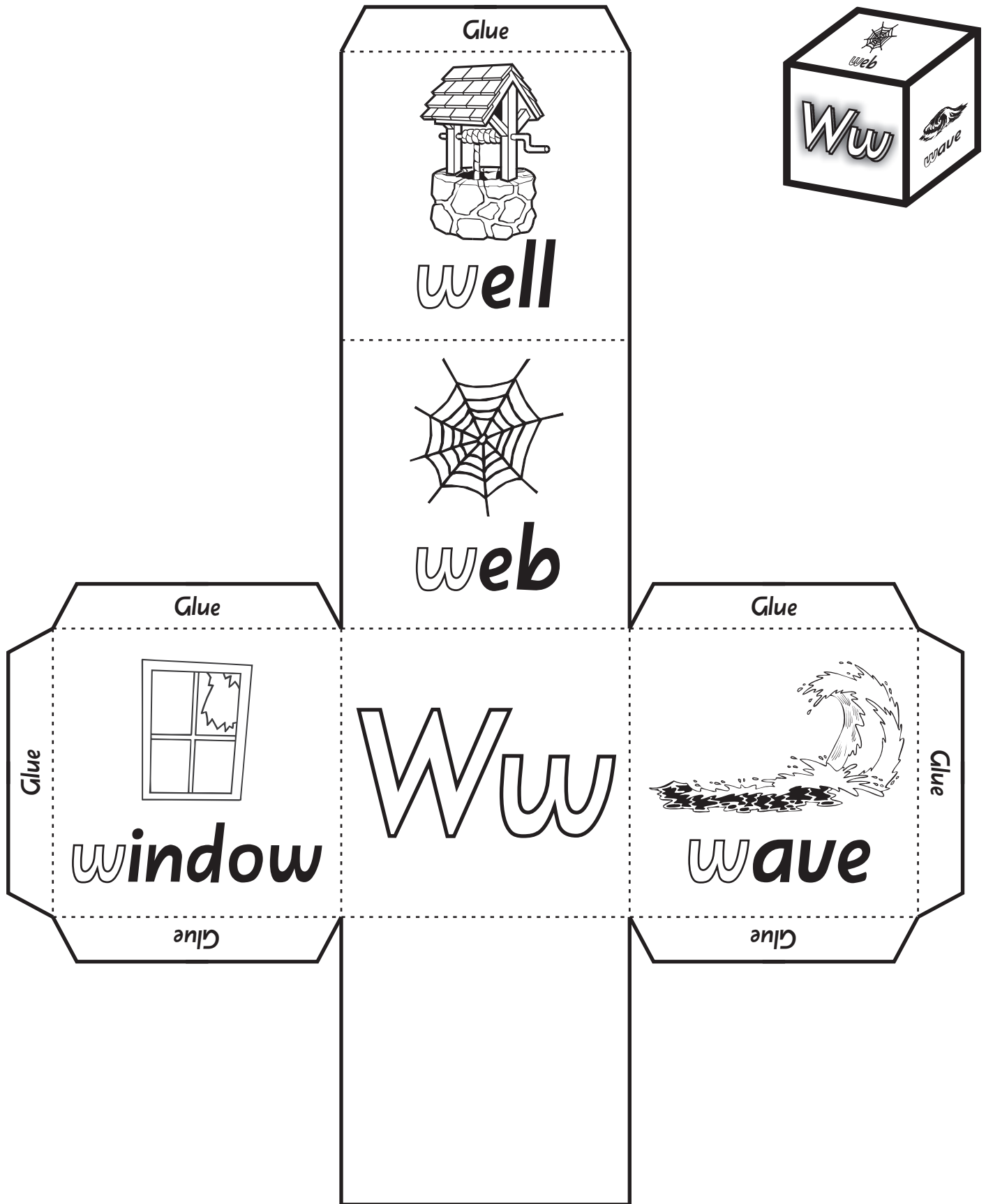

Colour in the big *Ww* sounds.



Colour the *w* pictures.



Trace over the *w* sounds in the words.



Draw your own *w* picture in the blank square.

Cut along the straight lines and fold along the dotted lines. Glue it together to make a cube.



Trace any w sounds. Colour any picture that starts with w.

w

w

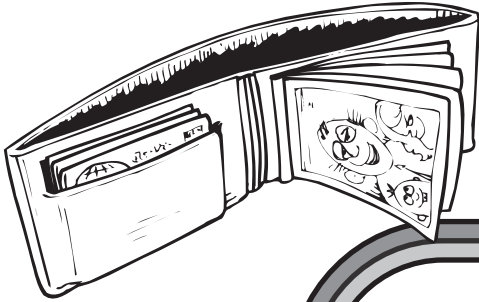

u

w

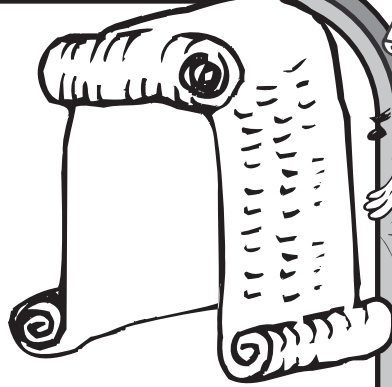

wig

w

Draw your own w picture.

m

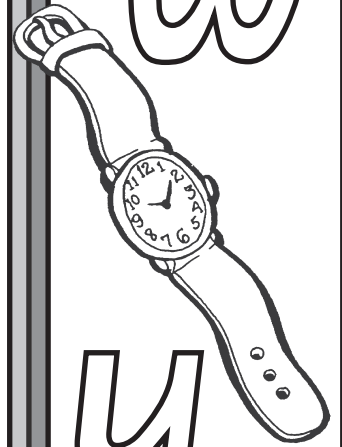

y

w

y

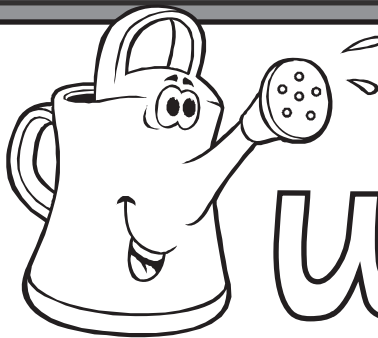
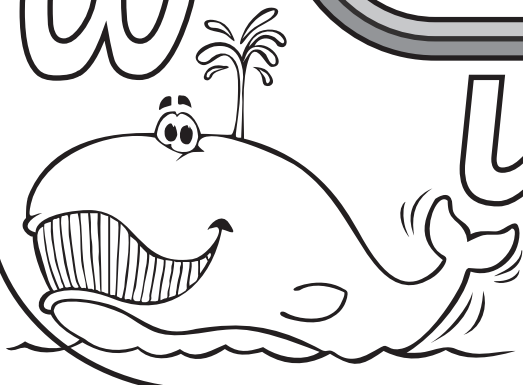

w



Draw a line to match the picture and word. Write the sound.

w W

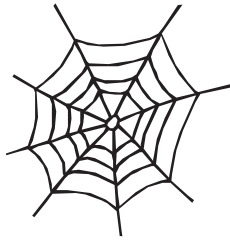

all

orm

ing

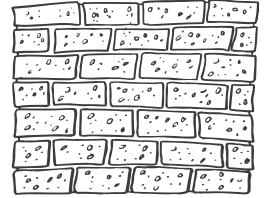

eb

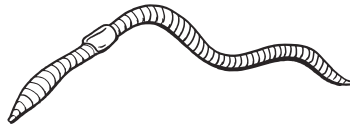

ind

Circle the words that start with w.

wag

wax

whale

where

mum

why

wink

nice

wet

were

win

van

wide

There are  w words.

Colour the pictures that start with w.

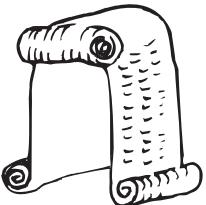
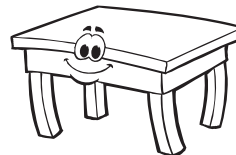
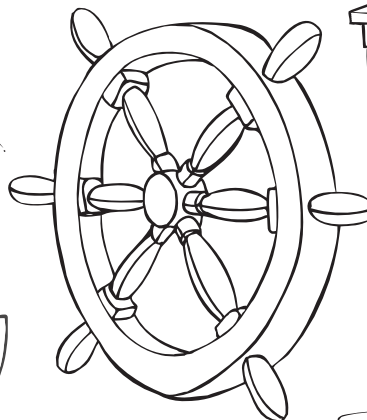
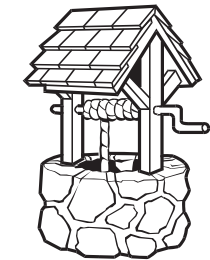

W  
w



PICK A  
CRAFT  
IDEA



- 1** Use sponge printing to colour the wombat brown.  
Shade the background green with chalk and add some grass with green crayon.
- 2** Cut fringes of brown or grey paper to paste on the wombat's body.  
Write *w* words around the finished product.
- 3** Fill the wombat's body with *w* words and cut and paste onto your display.  
Enlarge some wombats for adults, leave babies A4 size or shrink.

Trace the x sounds.

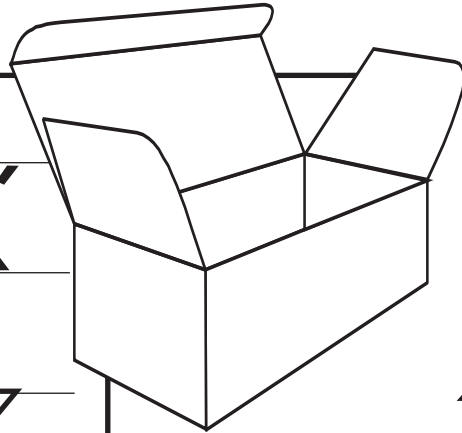
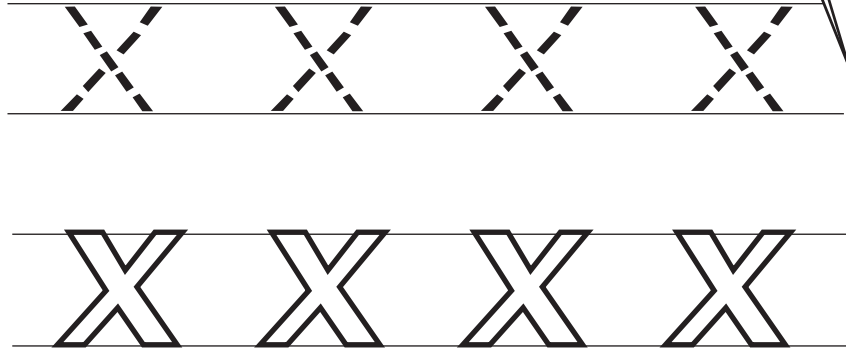

X

box

Colour the pictures that have x in them.

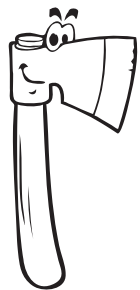
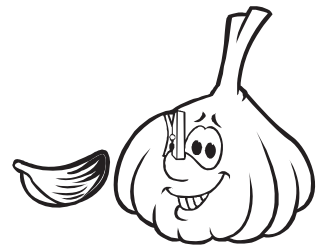
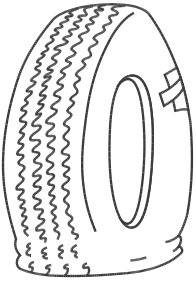

Trace the boxes and their numbers. Colour them in.  
Read the sentence and trace the x sounds.

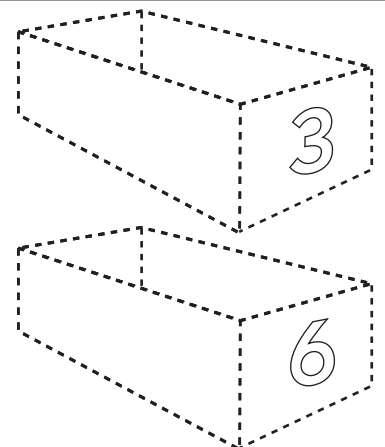
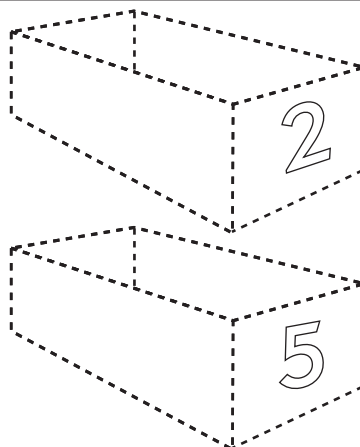
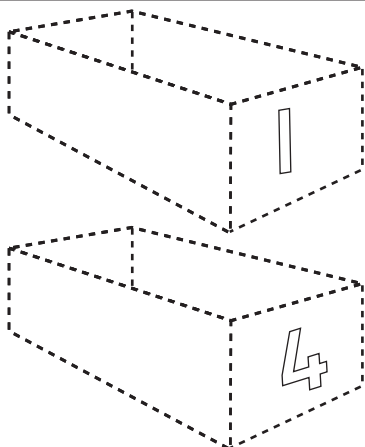

There are six boxes.

xX

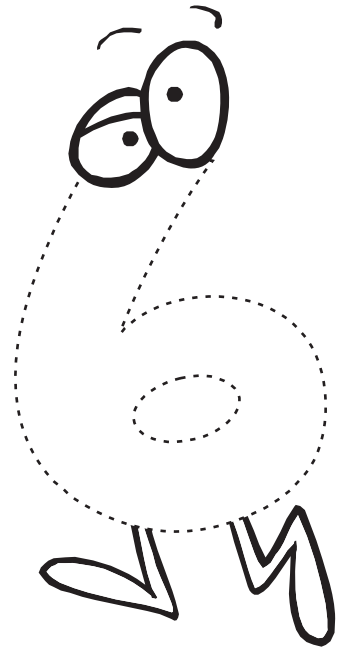
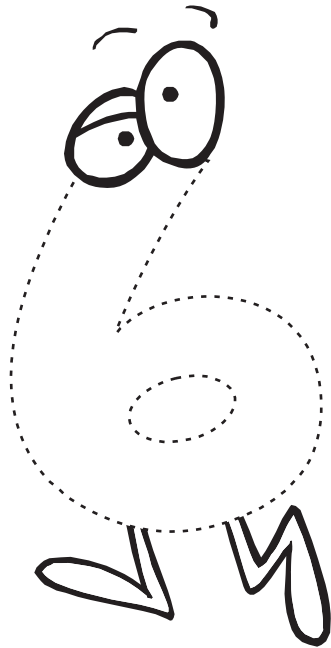
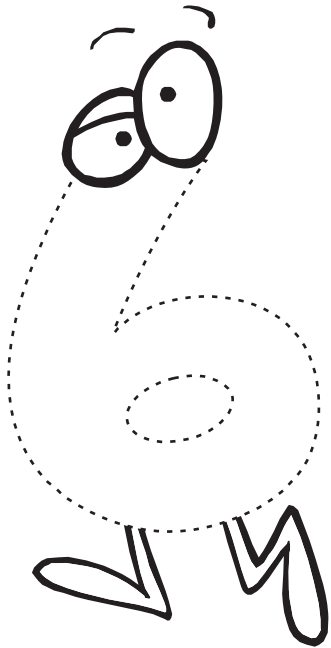
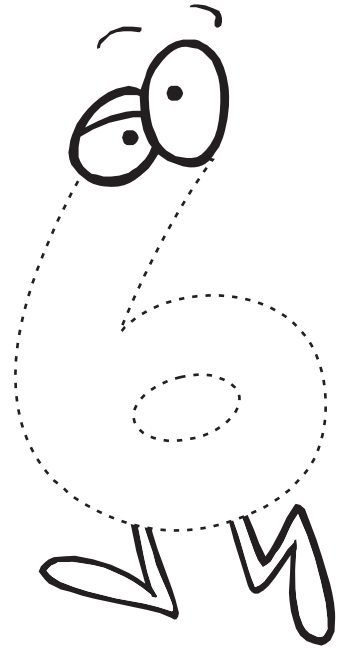
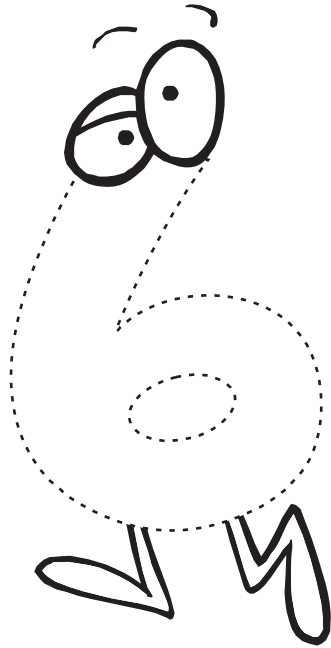
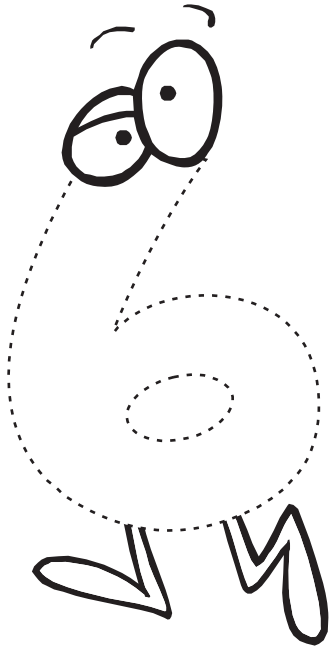

**There are six *x* sixes.**



Trace around the sixes.



Draw six *x* in each six.



Colour the background of each six a different colour.



Trace over the *x* sounds in the sentence.

# x X

1. Colour the pictures that have an **x** in them.
2. Trace the words that have an **x** in them.

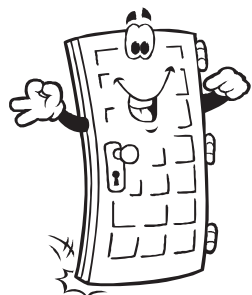

door

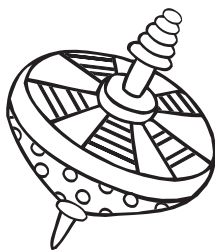

top



fax



rope

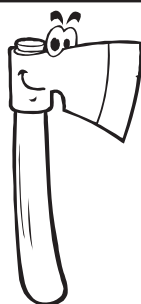

axe

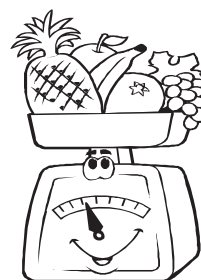

scales



Santa

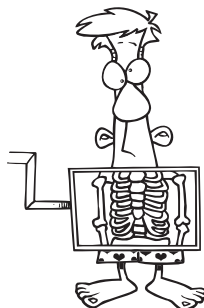

x-ray

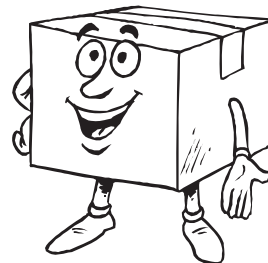

box



six



taxi



rattle

Write some **x** words on another sheet  
or find some **x** pictures in magazines or newspapers.

EXTRA  
STUFF



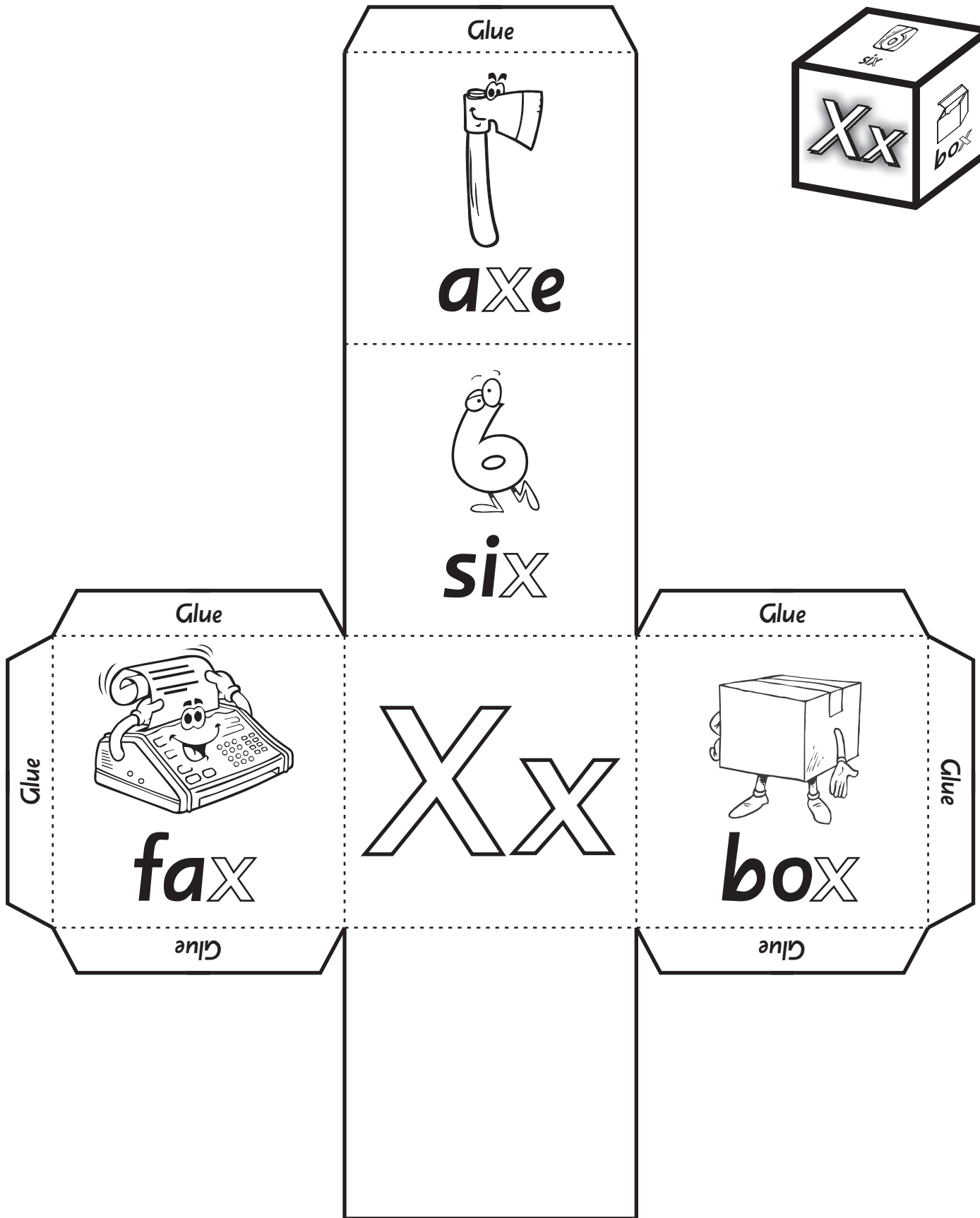
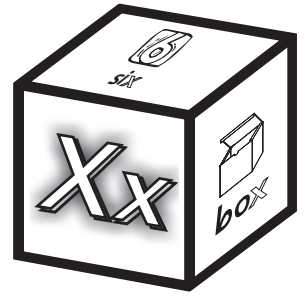

Colour in the big Xx sounds.



Colour the x pictures.



Trace over the x sounds in the words.



Draw your own x picture in the blank square.

Cut along the straight lines and fold along the dotted lines. Glue it together to make a cube.



Trace any x sounds. Colour any picture that has x in it.

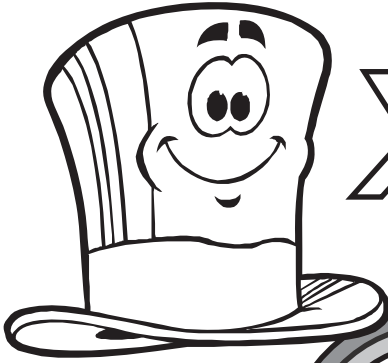

X

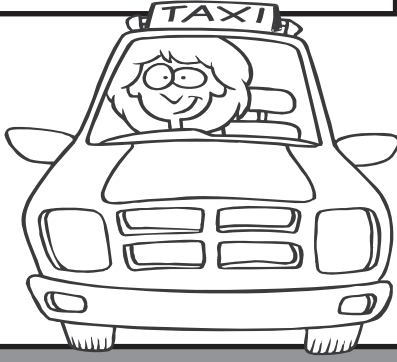

X

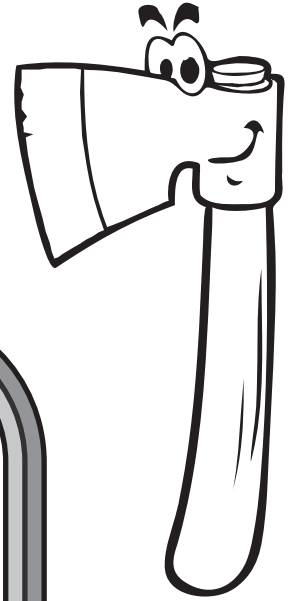

w

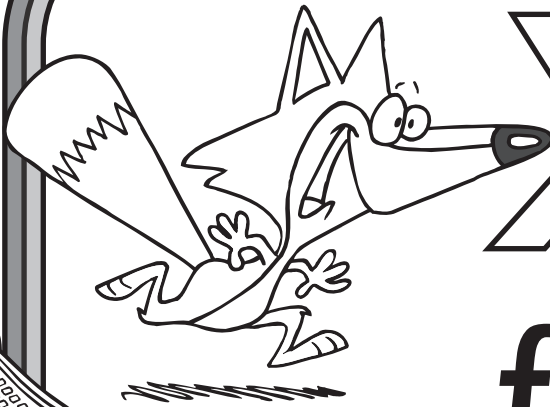

X

fox

Z



Draw your own x picture.

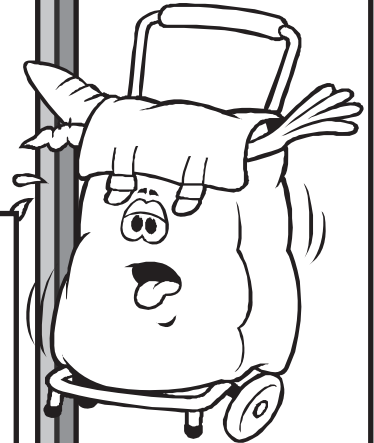

X

X

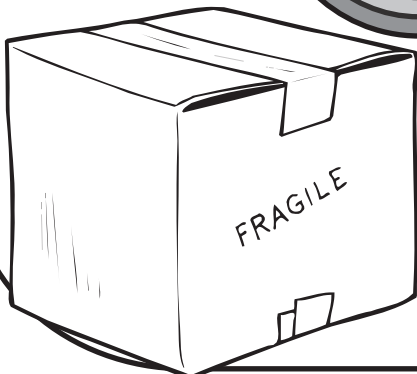
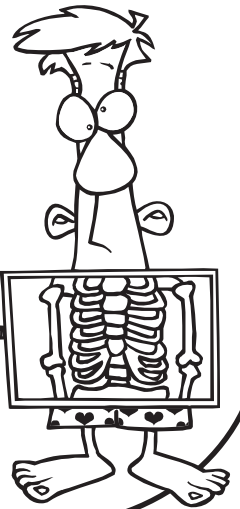

+



X

x X

Draw a line to match the picture and word. Write the sound.

fi

ray



fo

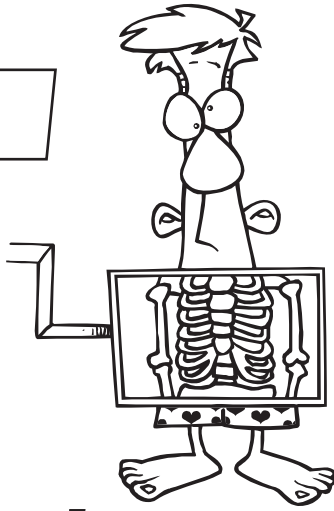

si

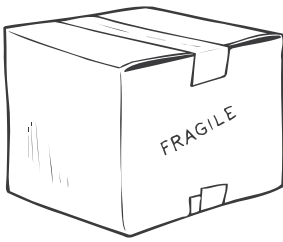
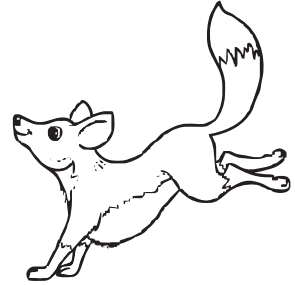

bo

Circle the words that have an x in them.

taxi car fox kite fax

box sat habit axe

six back boxer examine

There are  x words.

Colour the pictures that have any x sounds.

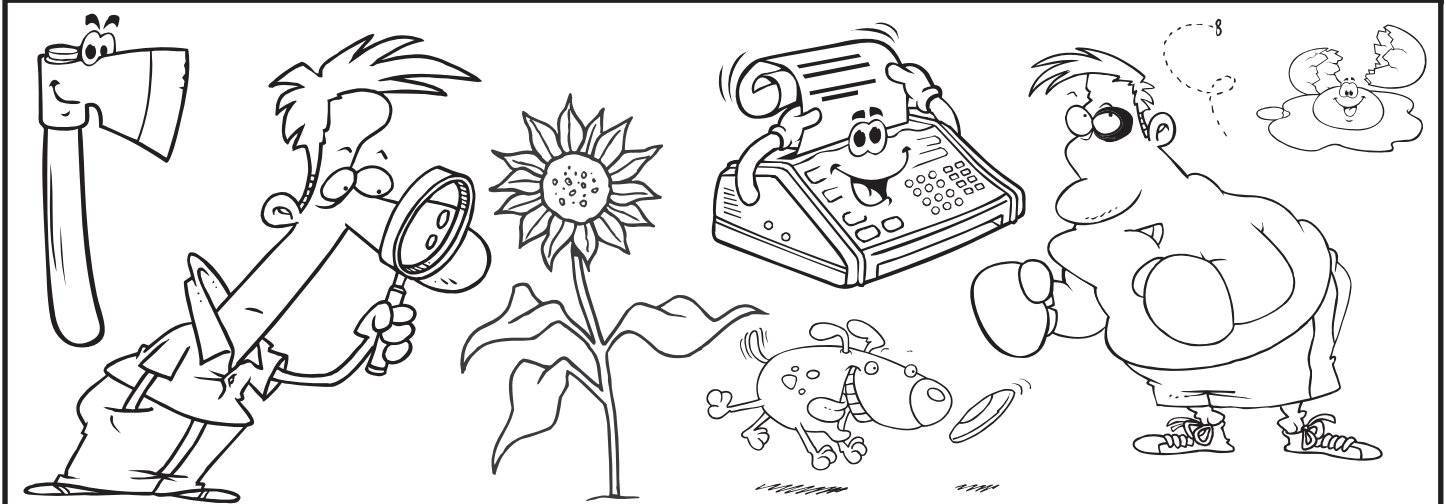

x X

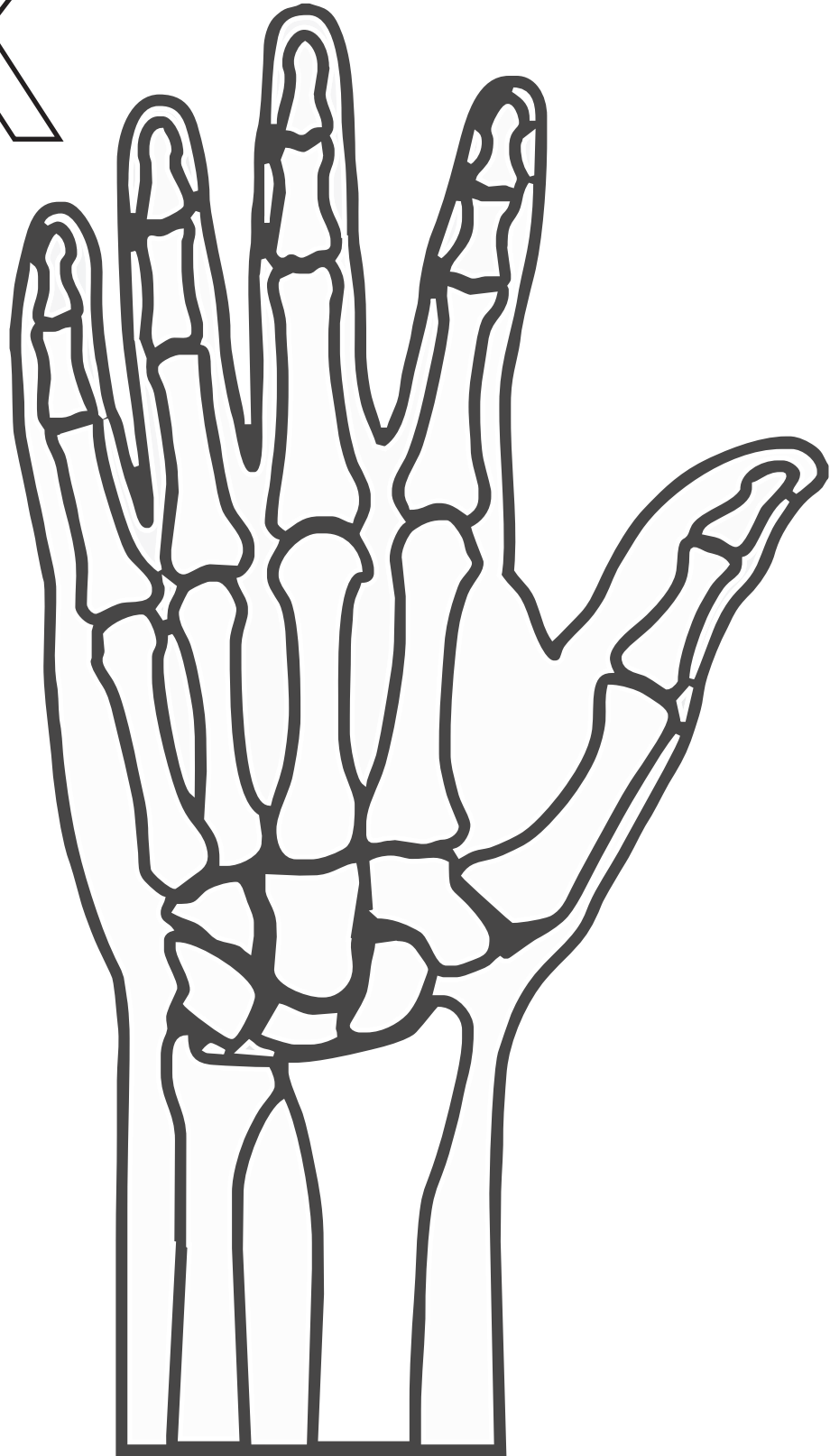

- 1** Colour the hand black, leaving the bones white to write words containing the letter x.
- 2** Cut out the bones a few at a time, and reassemble them by pasting onto black paper or cardboard. Leave spaces between the bones.
- 3** Colour the bones with a white crayon and then paint over the bones with a black wash.

Trace the y sounds.

y

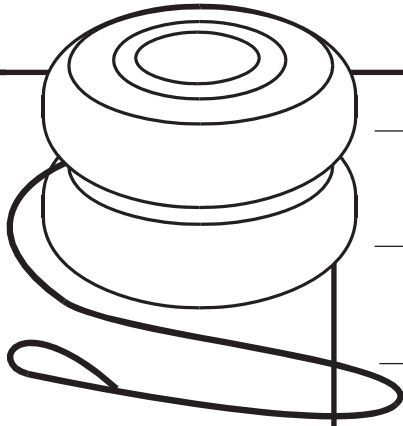

yo-yo

y y y y

y y y y

Colour the pictures that start with y.

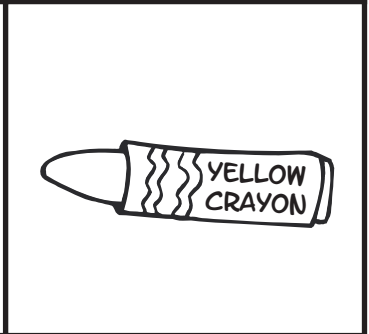
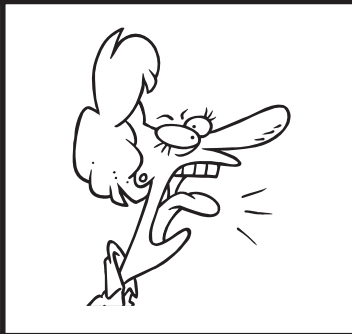
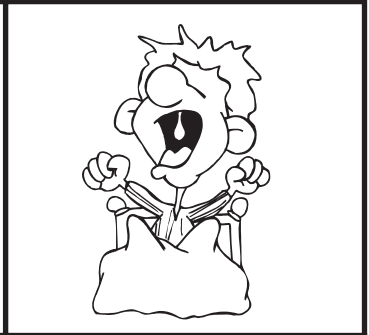
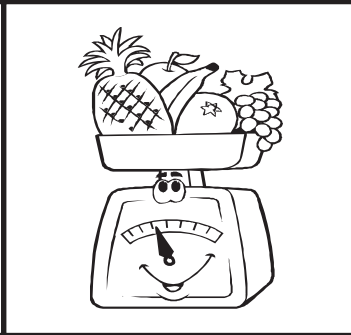
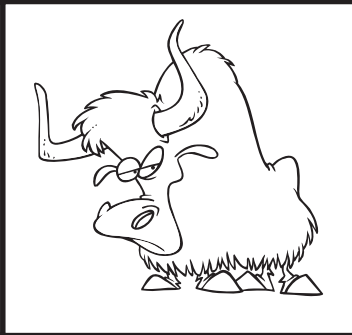
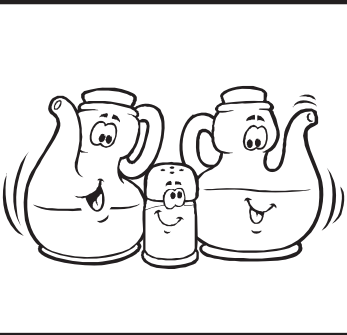

Trace the strings with different colours to match the yo-yos to the hands. Read the sentence and trace the y sounds.

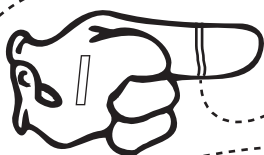

There is a yellow yo-yo.



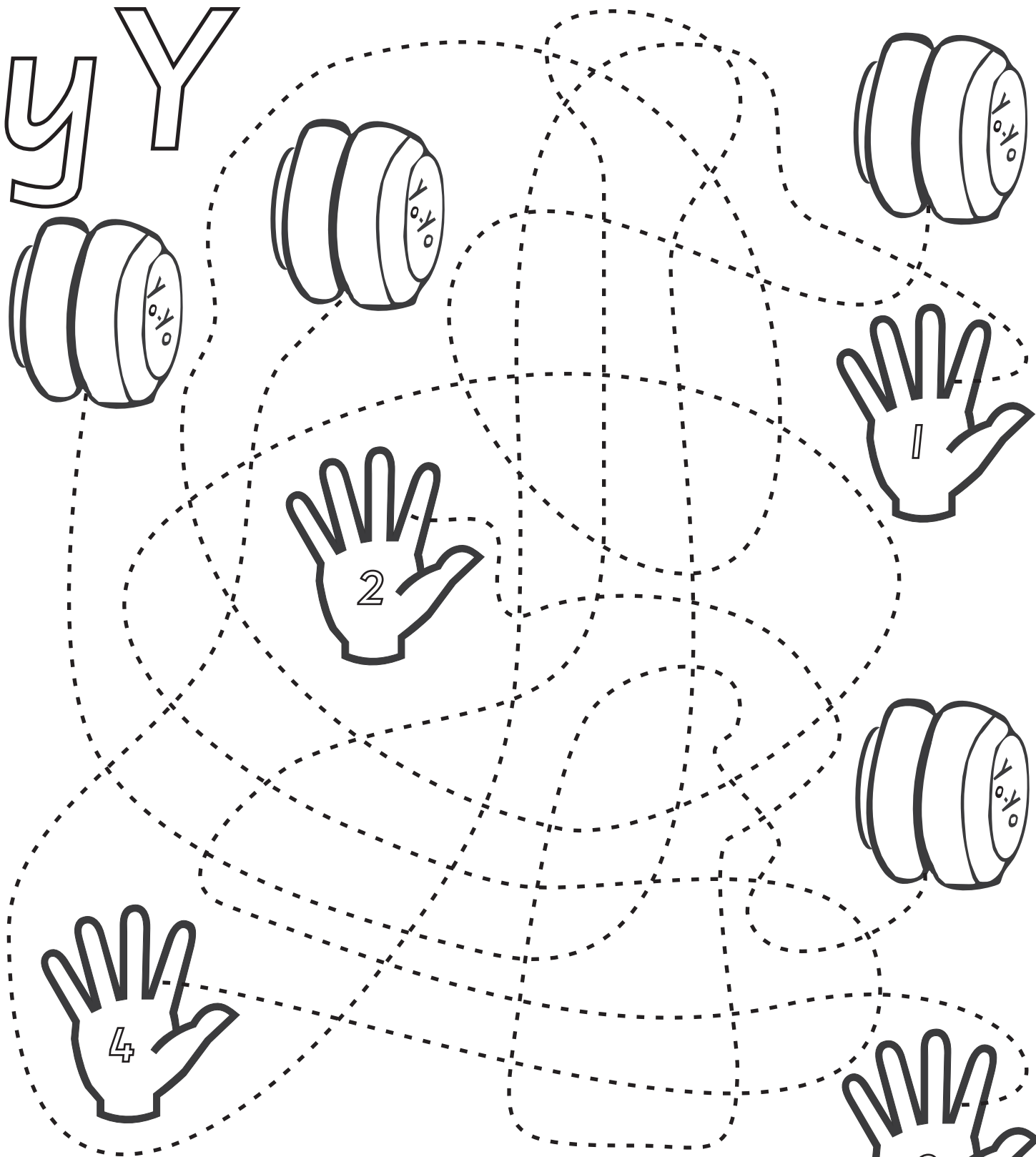

I have a yellow yo-yo.



Colour each yo-yo a different colour (make one yellow).



Trace over the strings from the hands to the yo-yos.



Trace over the *y* sounds in the sentence.

# y Y

1. Colour the pictures that start with y.
2. Trace the y words.



yell



wash



sneeze

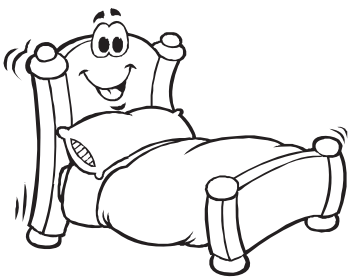

bed



yak



yawn

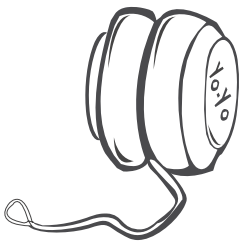

yo-yo

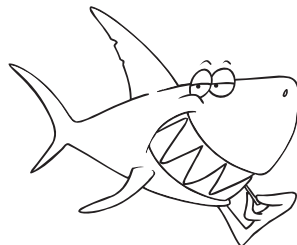

shark



yoghurt



caterpillar



yacht



yellow

Write some y words on another sheet  
or find some y pictures in magazines or newspapers.







Trace any y sounds. Colour any picture that starts with y.



y

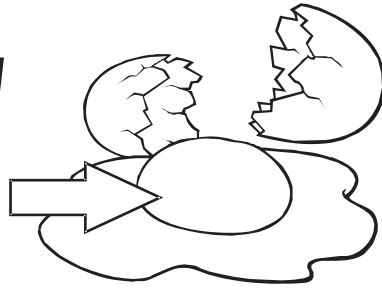

y

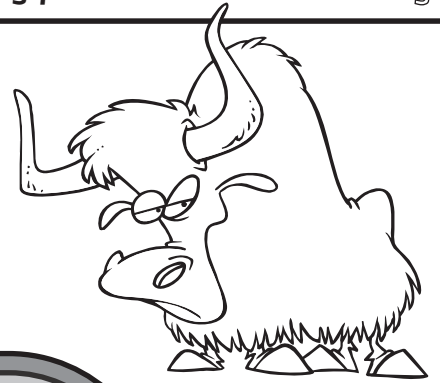

p

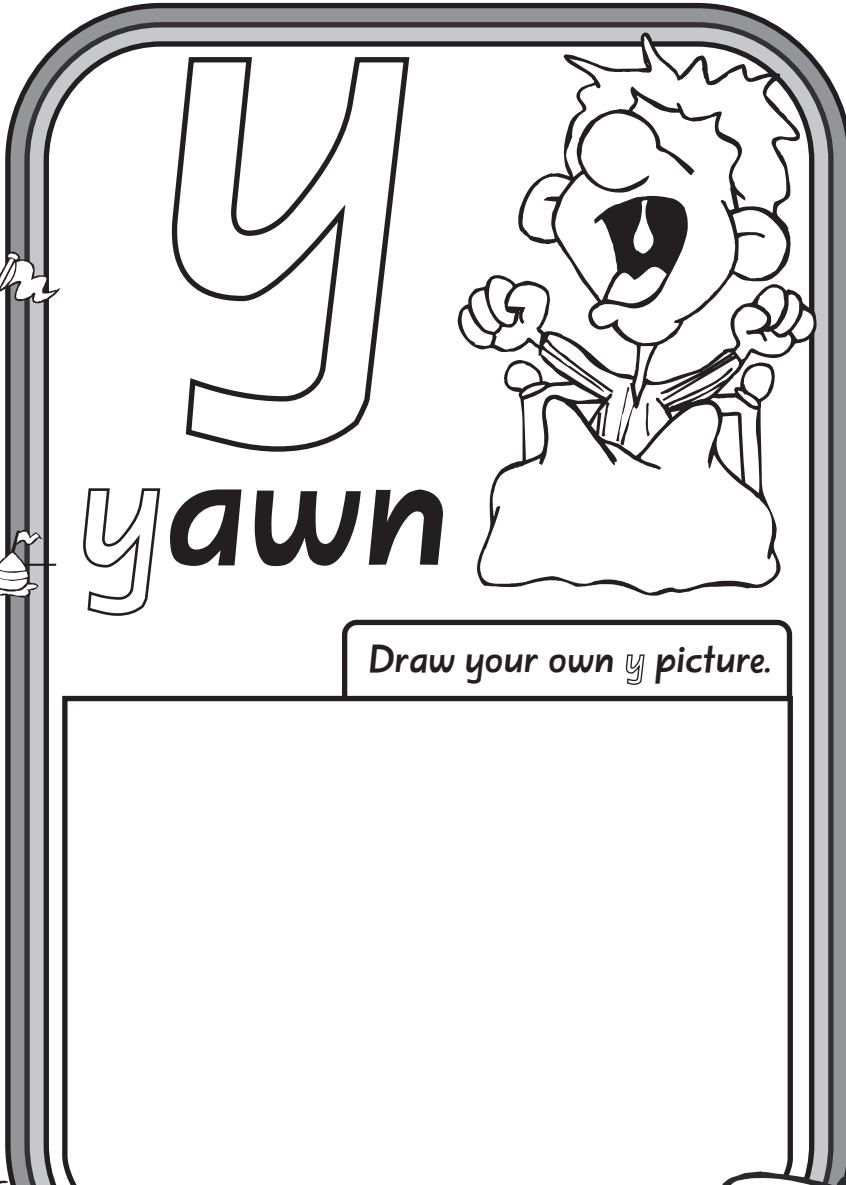

Draw your own y picture.

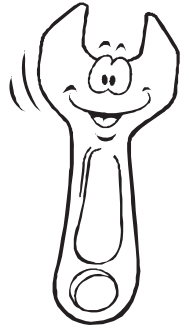

y

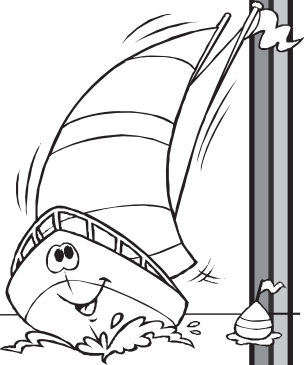

y

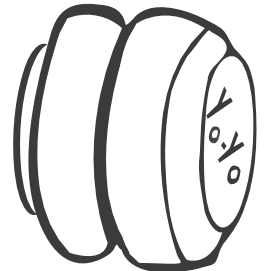

u

g



y

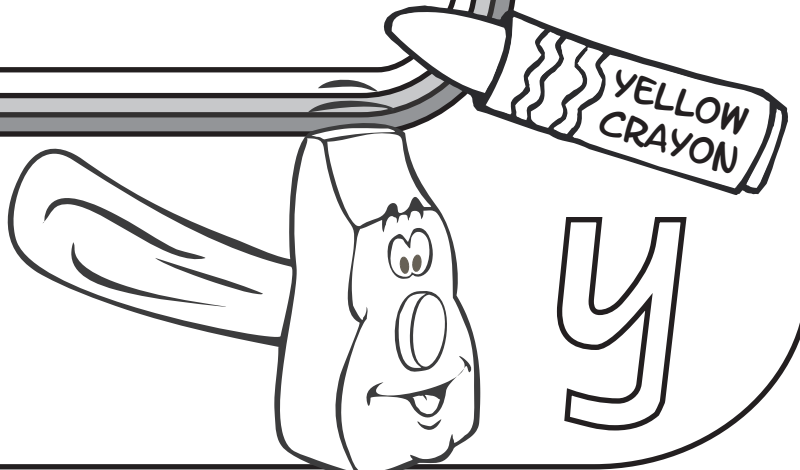

y

Draw a line to match the picture and word. Write the sound.

y Y

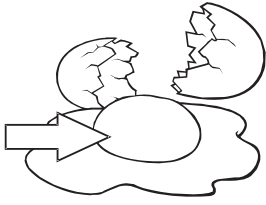

ak



oghurt



acht

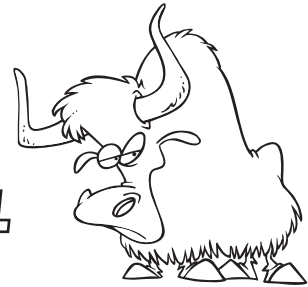

olk

ell



Circle the words that start with y.

green      young      yellow      yet  
gone      yap      yak      youth  
yard      year      train      yoga

There are  y words.

Colour the pictures that start with y.

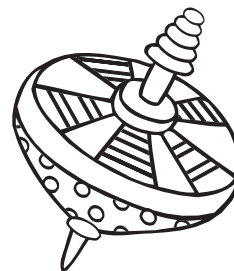
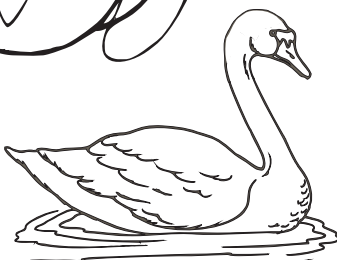
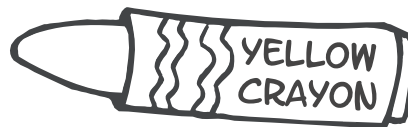
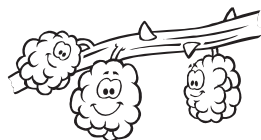
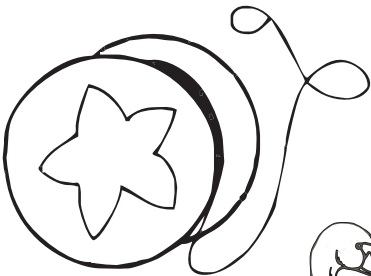

y Y



PICK A  
CRAFT  
IDEA



- 1** Colour the yacht with crayon and draw patterns on the sails.  
Paint over the yacht with a pale blue wash for the water.
- 2** Fill the yacht with *y* words. Cut out the yacht and paste it on a large display board covered with blue paper.
- 3** Paint a separate piece of paper with a blue wash. When it is dry, use a crayon to draw waves. Colour and cut out the yachts and paste onto this background.

Trace the z sounds.

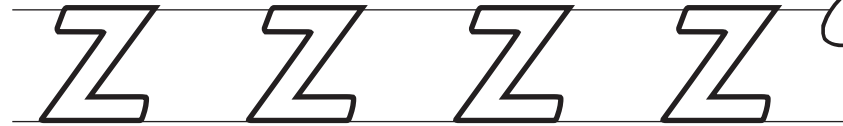

Z

zebra

Colour the pictures that start with z.

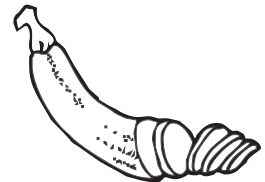
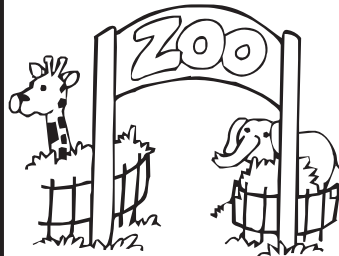
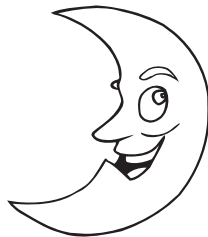
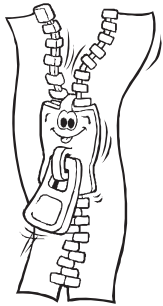
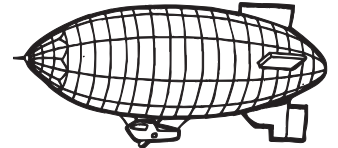
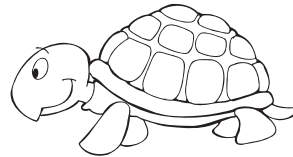
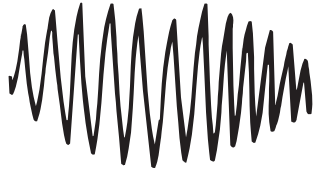
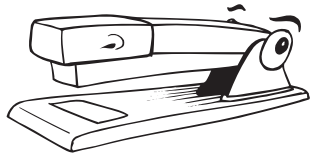

Trace the zig-zags and colour them green.  
Read the sentence and trace the z sounds.

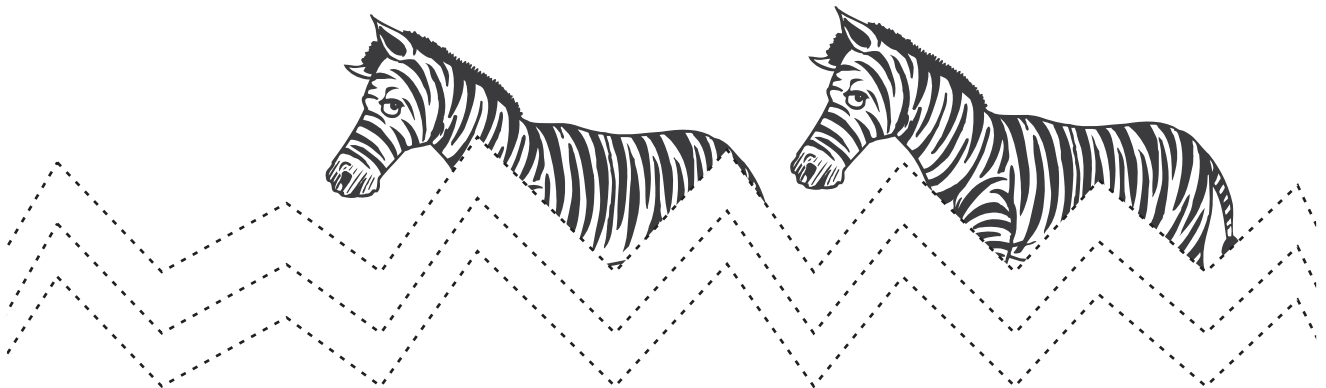

The zebra hide in the zig-zags.

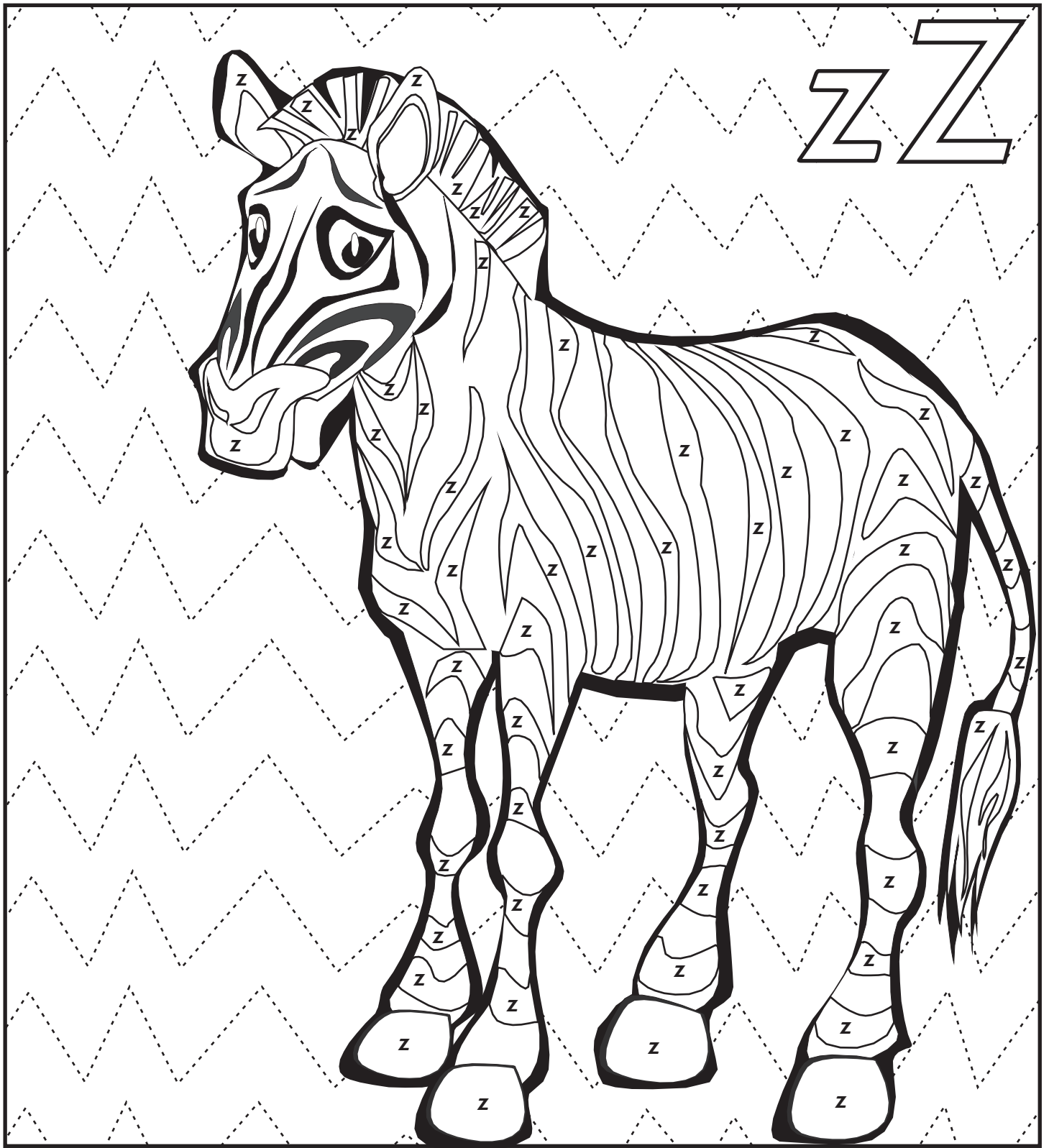

**The zebra can see lots of zig zags.**

- ☺ Colour the stripes with the z sounds black.
- ☺ Trace over the zig zags in different colours.
- ☺ Shade the background in green chalk or pencil.
- ☺ Trace over the z sounds in the sentence.

# z Z

1. Colour the pictures that start with z.
2. Trace the z words.

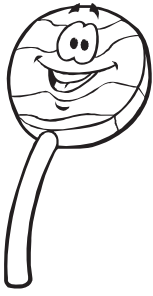

lollypop

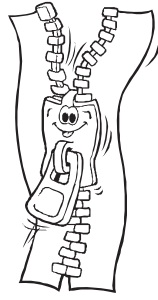

zipper

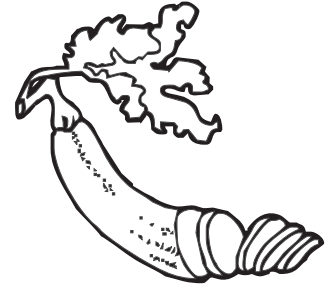

zucchini

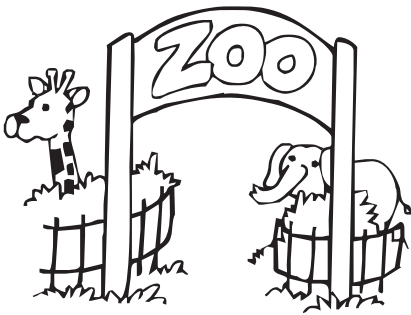

zoo



arrow

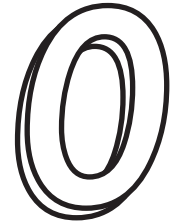

zero

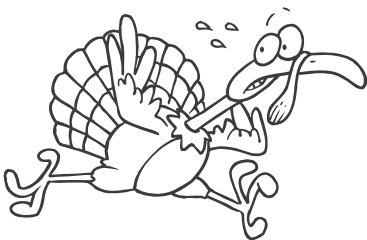

turkey

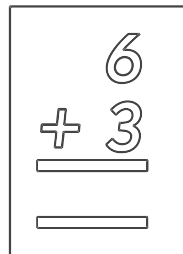

sum



zebra

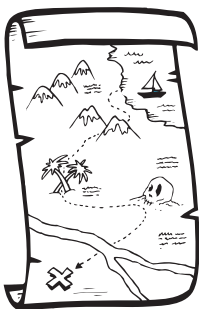

map

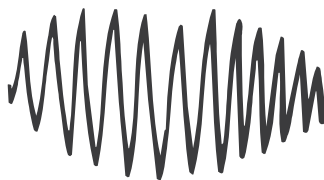

zigzag

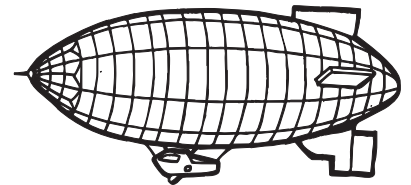

zeppelin

Write some z words on another sheet  
or find some z pictures in magazines or newspapers.



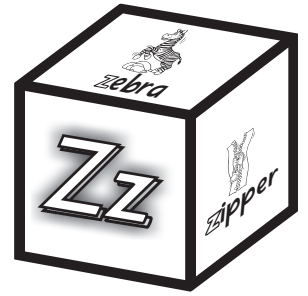

Glue

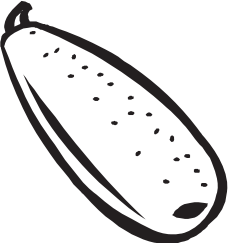

**zucchini**

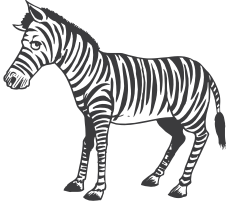

**zebra**

Glue



Glue

Glue

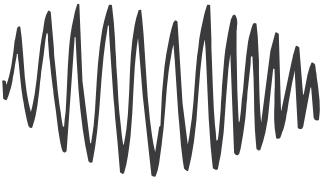

**zig-zag**

Glue



**zipper**

Glue

- ☺ Colour in the big **Zz** sounds.
- ☺ Colour the **z** pictures.
- ☺ Trace over the **z** sounds in the words.
- ☺ Draw your own **z** picture in the blank square.

Cut along the straight lines and fold along the dotted lines. Glue it together to make a cube.



Trace any z sounds. Colour any picture that starts with z.



Z

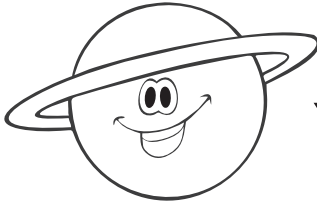

X

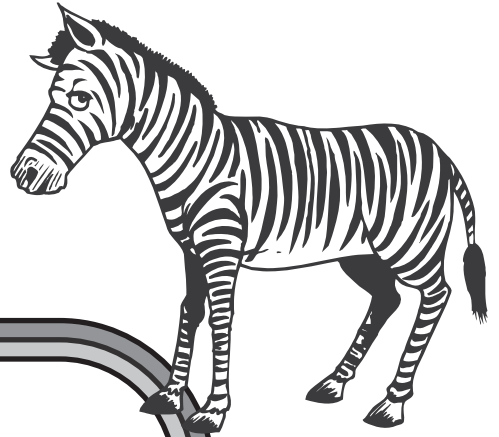

n

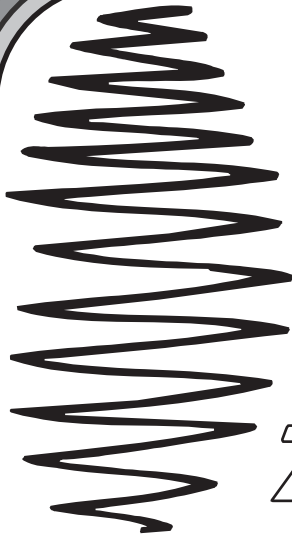

Z

Z



zig zag

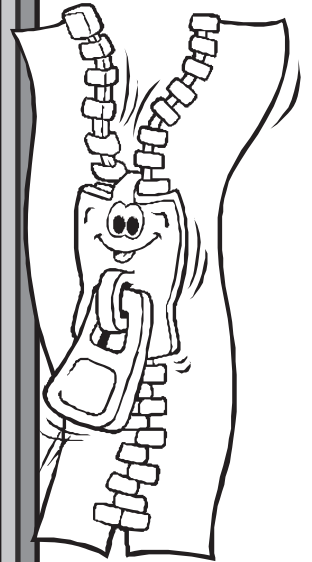

Z

Draw your own z picture.

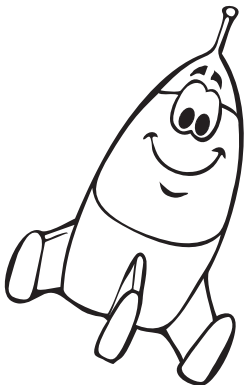

Z

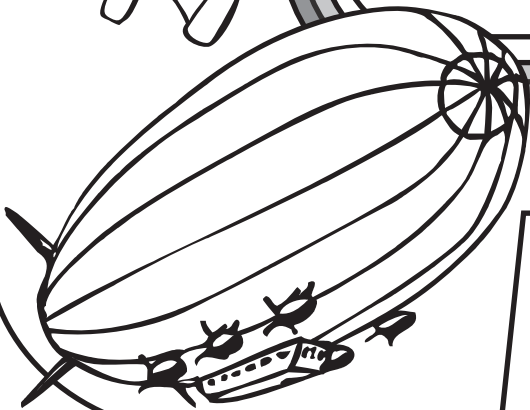

k

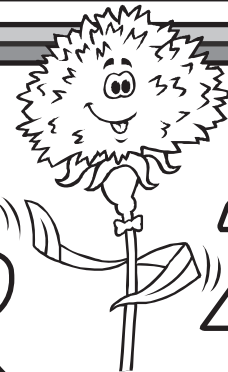

Z

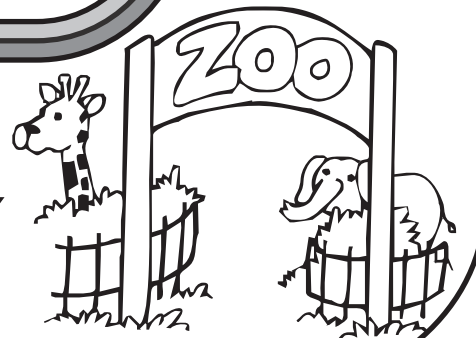

z Z

Draw a line to match the picture and word. Write the sound.

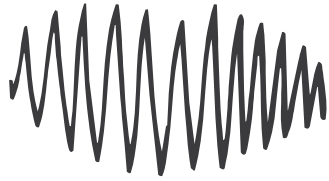

Zipper

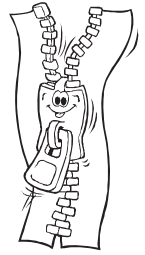

Zoom

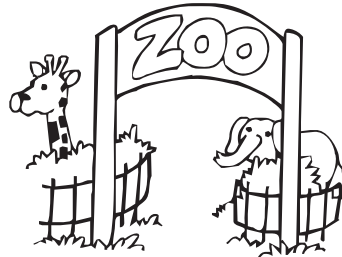

Zebra

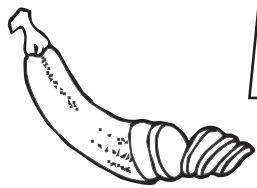

Zig-zag

Zucchini

Circle the words that start with z.

zoom

zebra

zero

soon

zeal

rent

zodiac

zap

zinc

goat

zoo

zig-zag

There are  z words.

Colour the pictures that start with z.

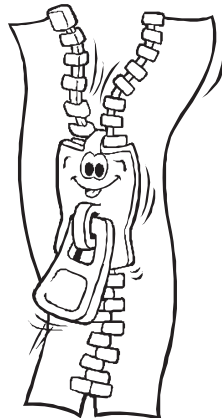

z z

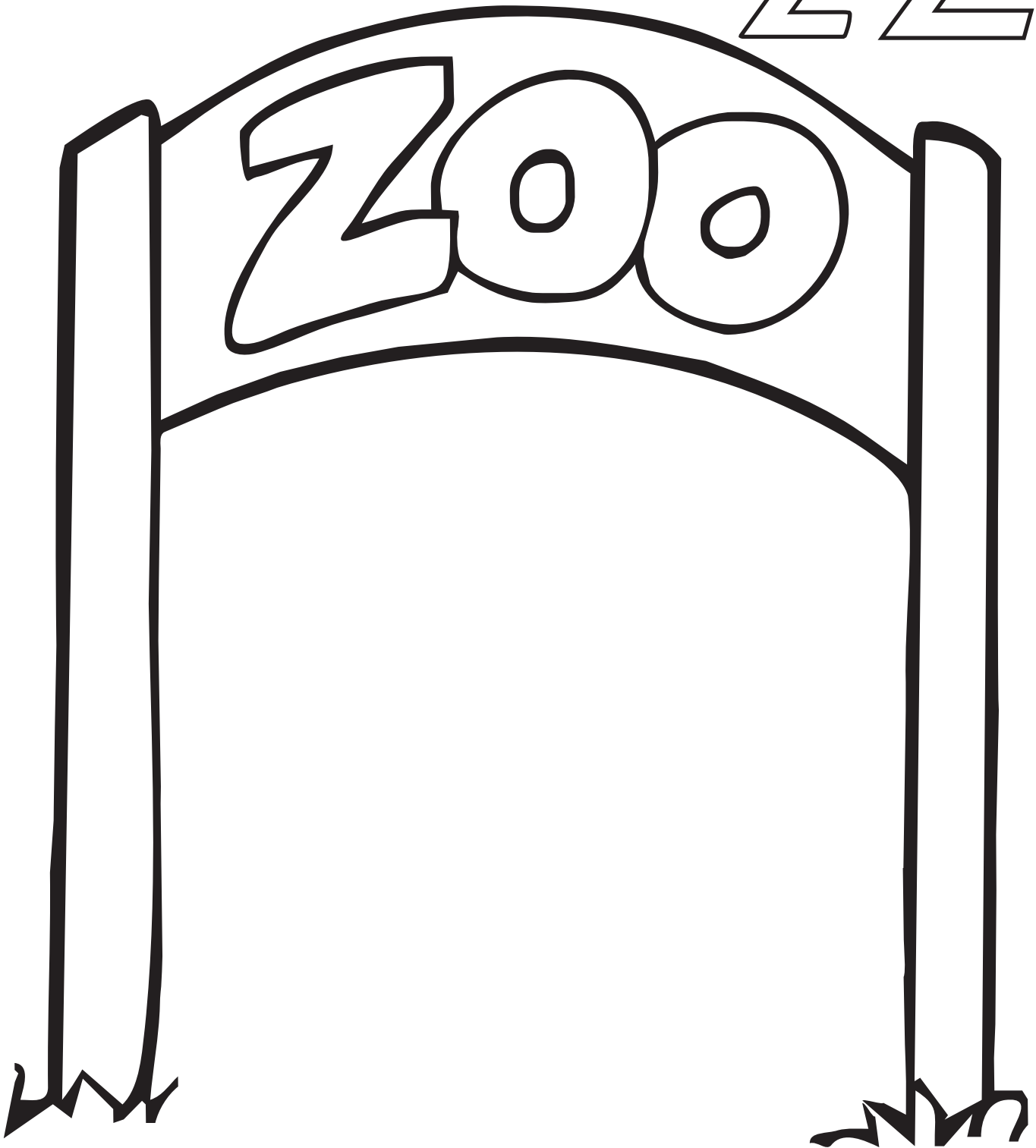

PICK A  
CRAFT  
IDEA



- 1** Colour the zoo sign in crayon.  
Cut out pictures or draw animals and paste around the sign.
- 2** Paint the zoo sign.  
Surround the sign with words starting with z.
- 3** Colour the zoo sign.  
Draw people walking through the entrance. Draw animals in the background.

**Complete Single Sounds** provides a comprehensive programme to introduce single sounds.

- \* Each single sound has seven pages of interesting and varied activities that will provide practise in the visual, oral and aural recognition of the sound.
- \* Activities include art and craft pages, tracing the sound, colouring pictures that start with the sound and writing the sound.
- \* There are over 180 pages of fun and motivating activities for the young student to practise the recognition of single sounds.
- \* Learning single sounds is the first step in the development of the phonetic skills needed to learn to read.

This book is suitable for the following grades in different states.

	NSW	ACT	VIC	TAS	WA	NT	SA	QLD	NZ
K, Prep	✓	✓	✓	✓					
1					✓	✓	✓	✓	✓
2									
3									
4									
5									
6									
7									

LOWER MIDDLE UPPER

**Burrabooks** publications are written by Australian teachers who have had extensive classroom experience.

For more information visit:

[www.burrabooks.com.au](http://www.burrabooks.com.au)



**BURRABOOKS**

[www.burrabooks.com.au](http://www.burrabooks.com.au)  
[mail@burrabooks.com.au](mailto:mail@burrabooks.com.au)